

Commercial Microwave—Technical Information

208/230 VAC, 60 Hz Models

RC17S2	P2001801M	MRC17S2	P2001802M
RC17SDOSI	P2001803M	RC22S2	P2001804M
DQ22HSI	P2001806M	MC23MPW2	P2001807M
MC23MPTW2	P2001808M	WDYRC22	P2001809M
KFC2W2	P2001810M	RC30S2	P2001811M
MRC30S2	P2001812M		

- Due to possibility of personal injury or property damage, always contact an authorized technician for servicing or repair of this unit.
- Refer to Service Manual for installation, operating, testing, troubleshooting, and disassembly instruction.



CAUTION

All safety information must be followed as provided in Service Manual.



WARNING

To avoid the risk of electrical shock, personal injury or death; disconnect power to oven and discharge capacitor before servicing, unless testing requires power.





Models	RC17S2 MRC17S2 RC17SD2OSII	RC22S2 DQ22HSI2 WDYRC22	RC30S2 MRC30S2	KFC2W2	MC23MPTW2 MC23MPW2
Power Source					
Voltage AC	208/230 VAC	208/230 VAC	208/230 VAC	208/230 VAC	208/230 VAC
Amperage (Single Unit)	20 A	20 A	30 A	30 A	20 A
Frequency	60 Hz	60 Hz	60 Hz	60 Hz	60 Hz
Single Phase, 3 wire grounded	X	X	X	X	X
Receptacle	6-20R	6-20R	6-30R	6-30R	**
Plug	6-20P	6-20P	6-30P	6-30P	**
Power Output – Microwave					
Nominal microwave energy (IEC705)	1700 Watts	2200 Watts	3000 Watts	2700 Watts	2000 Watts
Operating Frequency	2450 MHz	2450 MHz	2450 MHz	2450 MHz	2450 MHz
Power Consumption					
Microwave only	2700 Watts	3200 Watts	4400 Watts	4100 Watts	3200 Watts
Dimensions					
Cabinet (in cm)					
Width	19 1/4" 49 cm	19 1/4" 49 cm	19 1/4" 49 cm	19 1/4" 49 cm	19 1/4" 49 cm
Height	18 1/4" 46 cm	18 1/4" 46 cm	18 1/4" 46 cm	18 1/4" 46 cm	18 1/4" 46 cm
Depth	26 1/4" 67 cm	26 1/4" 67 cm	26 1/4" 67 cm	26 1/4" 67 cm	26 1/4" 67 cm
Oven Interior (in cm)					
Width	13" 33 cm	13" 33 cm	13" 33 cm	13" 33 cm	13" 33 cm
Height	8 1/2" 22 cm	8 1/2" 22 cm	8 1/2" 22 cm	8 1/2" 22 cm	8 1/2" 22 cm
Depth	15" 38 cm	15" 38 cm	15" 38 cm	15" 38 cm	15" 38 cm
Weight					
Uncrated	94 lbs.	94 lbs.	115 lbs.	115 lbs.	115 lbs.
Crated	101 lbs.	101 lbs.	123 lbs.	123 lbs.	123 lbs.

** MC23MPTW2, MC23MPW2 uses 20A Twist-Loc NEMA L6-20P plug

Component Testing Procedures

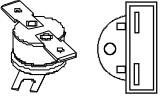
⚠ WARNING

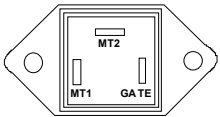
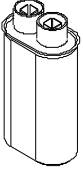
To avoid risk of electrical shock, personal injury or death; disconnect power to oven and discharge capacitor before servicing, unless testing requires power.

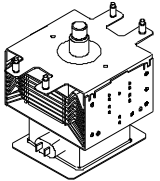
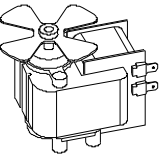
Illustration	Component	Test	Results
	Thermal cutout	Disconnect all wires from TCO. Measure resistance across terminals. Magnetron TCO Cavity TCO.....	Open at 300°F (149°C) and closed at 257°F (125°C) Opens at 262°F (128°C)
	Diode	Discharge Capacitor Remove diode lead from capacitor and connect ohmmeter. Reverse leads for second test.	Infinite resistance should be measured in one direction and 50KΩ or more in the opposite direction. NOTE: Ohmmeter must contain a battery of 6 volts minimum.
 Triac 1 (center) Triac 2 (left) Triac 3 (right)	Triac	Resistance Check Disconnect wires to triac. Measure resistance from: MT1 to MT2 MT1 to Gate MT2 to Gate All terminals to ground	Caution - Do not operate oven with wire to terminal MT2 removed. Infinite Approximately 60 Ω Infinite Infinite
		Voltage Check Measure voltage from: MT1 to Gate	0.8 VAC when energized. If no voltage, check H.V. board and wiring.
	Capacitor Some units may use more than one type of capacitor. Refer to Parts Manual for correct capacitor quantity.	Discharge Capacitor Remove wires from capacitor terminals and connect ohmmeter, set on highest resistance scale to terminals. Also check between each terminal and capacitor case.	Between Terminals: Meter should momentarily deflect towards zero then return to over 5 MΩ. If no deflection occurs, or if continuous deflection occurs, replace capacitor. Terminal to Case: Infinite resistance
	Snubber assembly	Disconnect wires to snubber. Measure resistance across terminals.....	Infinite
	Magnetron	Discharge Capacitor Remove wires from magnetron and connect ohmmeter to terminals. Also check between each terminal and ground.	Between Terminals: Less than 1 Ω Each terminal to ground measures Infinite resistance. Note: This test is not conclusive. If oven does not heat and all other components test good replace the magnetron and retest.
	Blower motor	Remove all wires from motor. Measure resistance between: Orange and white terminals..... Yellow and white terminals	Approximately 31 Ω Approximately 29 Ω

Component Testing Procedures

⚠ WARNING

To avoid risk of electrical shock, personal injury or death; disconnect power to oven and discharge capacitor before servicing, unless testing requires power.

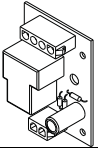
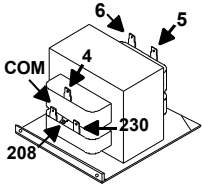
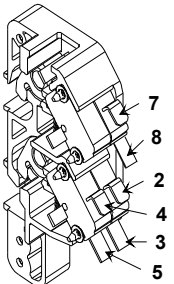
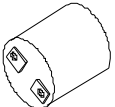
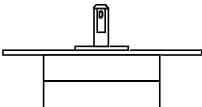
Illustration	Component	Test	Results
	Relay board	With power applied remove violet and brown 4 pin connector from J2 connector. With door closed measure resistance from: Pin 1 to pin 4 on J2 connector..... With door open measure resistance from: Pin 1 to pin 4 on J2 connector.....	Infinite Indicates continuity
	Transformer	Discharge Capacitor Remove all wires from terminals. Measure resistance from: 230 to COM 208 to COM 230 to Ground..... 208 to Ground..... Terminal 5 to 6 Terminal 4 to Ground	Less than 1 Ω Less than 1 Ω Infinite Infinite Less than 1 Ω Approximately 59 Ω
	Interlock switch	Disconnect wires to switch. With door open measure resistance from: Terminal 2 to 3 Terminal 4 to 5 Terminal 7 to 8 With door closed measure resistance from: Terminal 2 to 3 Terminal 4 to 5 Terminal 7 to 8	Infinite Infinite Infinite Indicates continuity Indicates continuity Indicates continuity
	Lamp receptacle (some models)	Test continuity of receptacle terminals.	Indicates continuity if bulb is good and screwed in.
	Antenna motor	Remove all wires from terminals. Measure resistance from: Terminal to terminal	Approximately 12K Ω
Refer to Parts Manual for proper power cord part number.	Power cord	Measure resistance of wires.	Continuity should be indicated on each wire. Verify polarity and grounding.

Component Testing Procedures

⚠ WARNING

To avoid risk of electrical shock, personal injury or death; disconnect power to oven and discharge capacitor before servicing, unless testing requires power.

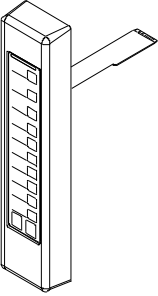
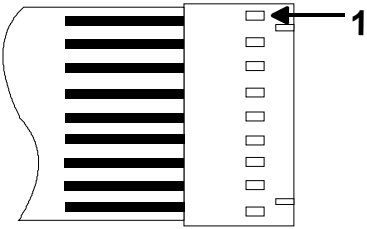
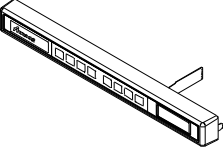
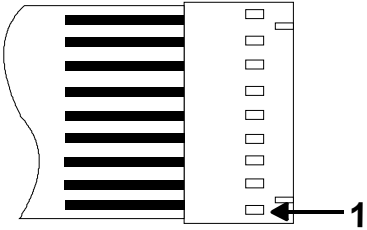
Illustration	Component	Test	Results		
	Side touch panel	Continuity is indicated as 100 Ω and below. 	Pad 1 2 3 4 5 6 7 8 9 0 Start Stop/Reset	Trace 3 & 5 3 & 6 3 & 7 3 & 8 3 & 9 4 & 5 4 & 6 4 & 7 4 & 8 4 & 9 5 & 6 6 & 9	Measurement Continuity Continuity Continuity Continuity Continuity Continuity Continuity Continuity Continuity Continuity Continuity Continuity
	Top touch panel	Removal of touch panel is required to perform test. Continuity is indicated as 100 Ω and below. 	Pad Time Entry Power Level Stage Program Save Quantity Menu Hidden Pad	Trace 5 & 7 5 & 8 5 & 9 6 & 7 6 & 8 7 & 9 8 & 9	Measurement Continuity Continuity Continuity Continuity Continuity Continuity Continuity

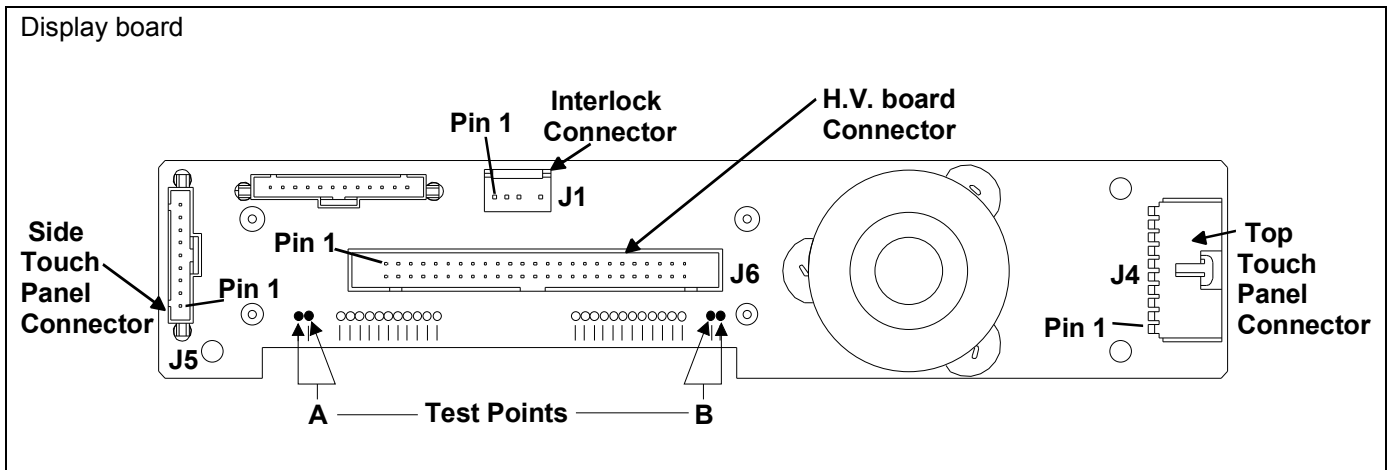

Function	Test Set-Up	Meter Setting	Probe Placement	Results
Input to Display Board	At Display Board	Volts	Test points A and B	3.0 VAC If voltage is present and no display is indicated, replace display board. If no voltage is present, check wire harness connections and H.V. board.

Component Testing Procedures

⚠ WARNING

To avoid risk of electrical shock, personal injury or death; disconnect power to oven and discharge capacitor before servicing, unless testing requires power.

H.V. board

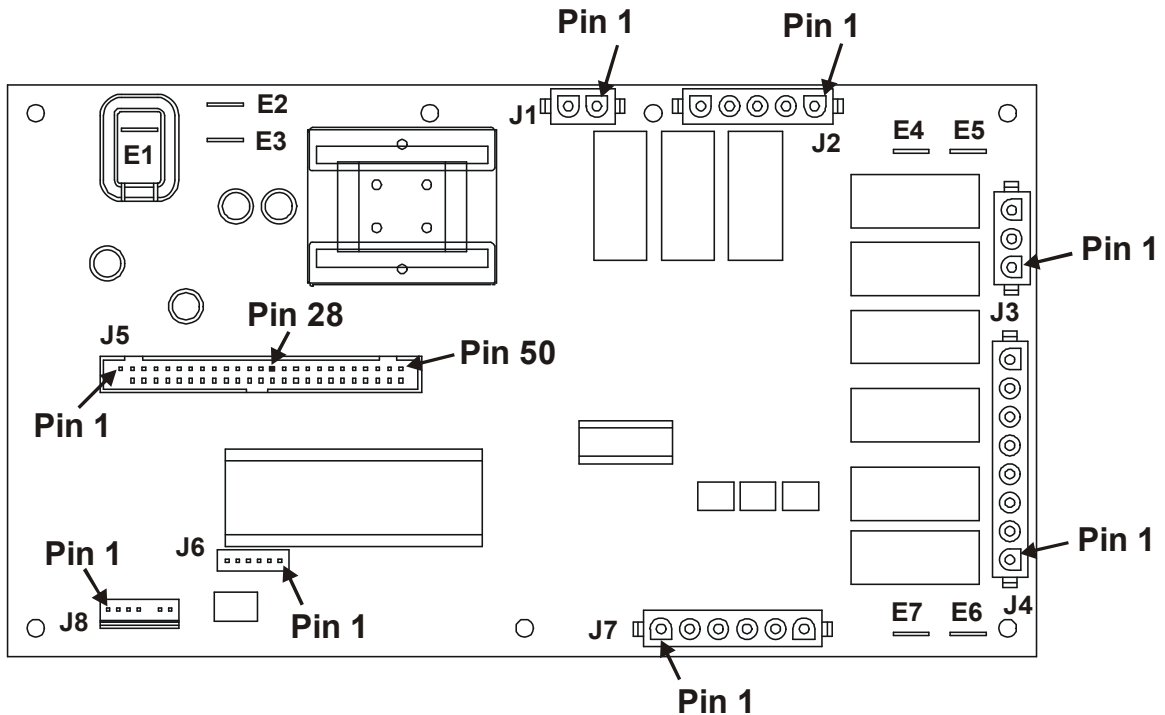

Function	Test Set-Up	Meter Setting	Probe Placement	Results
Input to H.V. board	At H.V. board	Volts	J1 pin 1 (Brown wire) & J1 pin 2 (White wire)	Line voltage
Output to display board	Disconnect J5 connector, blower runs continuously	Volts	J5 pin 28 & J5 pin 50	- 24 VDC

NOTE: For the following test, place oven in Service Test Mode (see page 11).

Relay	Function	Test Set-Up	Meter Setting	Probe Placement	Results
K1 at 230 VAC line voltage	Blower motor Antenna motor Cavity light	Disconnect J2 connector	Ohms	J1 pin 1 (Brown wire) & J2 pin 4	Test mode 5 off – no continuity Test mode 5 on – < 1 Ω
K2 at 208 VAC line voltage	Blower motor Antenna motor Cavity light	Disconnect J2 connector	Ohms	J1 pin 1 (Brown wire) & J2 pin 3	Test mode 5 off – no continuity Test mode 5 on – < 1 Ω

Component Testing Procedures



WARNING

To avoid risk of electrical shock, personal injury or death; disconnect power to oven and discharge capacitor before servicing, unless testing requires power.

H.V. Board – Relay Test

Three Magnetron Models – KFC2W2, MC23MPTW2, MC23MPW2, RC30S2 and MRC30S2

Relay	Function	Test Set-Up	Meter Setting	Probe Placement	Results
K8	Magnetron 1 (Top rear) at 230 VAC	All wires connected to H.V. board	VAC	E2 (Black wire) & J4 pin 2 (Red wire)	Test mode 1 off – line voltage Test mode 1 on – 0 volts
K9	Magnetron 1 (Top rear) at 208 VAC	All wires connected to H.V. board	VAC	E2 (Black wire) & J4 pin 1 (White wire)	Test mode 1 off – line voltage Test mode 1 on – 0 volts
K4	Magnetron 2 (Top front) at 230 VAC	All wires connected to H.V. board	VAC	E5 (Red wire) & J3 pin 1 (Gray wire)	Test mode 2 off – line voltage Test mode 2 on – 0 volts
K5	Magnetron 2 (Top front) at 208 VAC	All wires connected to H.V. board	VAC	E5 (Red wire) & J3 pin 3 (Orange wire)	Test mode 2 off – line voltage Test mode 2 on – 0 volts
K6	Magnetron 3 (Bottom) at 230 VAC	All wires connected to H.V. board	VAC	J4 pin 4 (Black wire) & J4 pin 6 (Black wire)	Test mode 3 off – line voltage Test mode 3 on – 0 volts
K7	Magnetron 3 (Bottom) at 208 VAC	All wires connected to H.V. board	VAC	J4 pin 4 (Black wire) & J4 pin 5 (Brown wire)	Test mode 3 off – line voltage Test mode 3 on – 0 volts

Two Magnetron Models – DQ22HSI2, RC17S2, RC17SDOSI, MRC17S2, RC22S2 and WDYRC22

Relay	Function	Test Set-Up	Meter Setting	Probe Placement	Results
K8	Magnetron 1 (Top rear) at 230 VAC	All wires connected to H.V. board	VAC	E5 (Red wire) & J4 pin 2 (Red wire)	Test mode 1 off – line voltage Test mode 1 on – 0 volts
K9	Magnetron 1 (Top rear) at 208 VAC	All wires connected to H.V. board	VAC	E5 (Red wire) & J4 pin 1 (White wire)	Test mode 1 off – line voltage Test mode 1 on – 0 volts
K6	Magnetron 3 (Bottom) at 230 VAC	All wires connected to H.V. board	VAC	J4 pin 4 (Black wire) & J4 pin 6 (Black wire)	Test mode 3 off – line voltage Test mode 3 on – 0 volts
K7	Magnetron 3 (Bottom) at 208 VAC	All wires connected to H.V. board	VAC	J4 pin 4 (Black wire) & J4 pin 5 (Brown wire)	Test mode 3 off – line voltage Test mode 3 on – 0 volts

Component Testing Procedures

WARNING

To avoid risk of electrical shock, personal injury or death; disconnect power to oven and discharge capacitor before servicing, unless testing requires power.

Three Magnetron Models

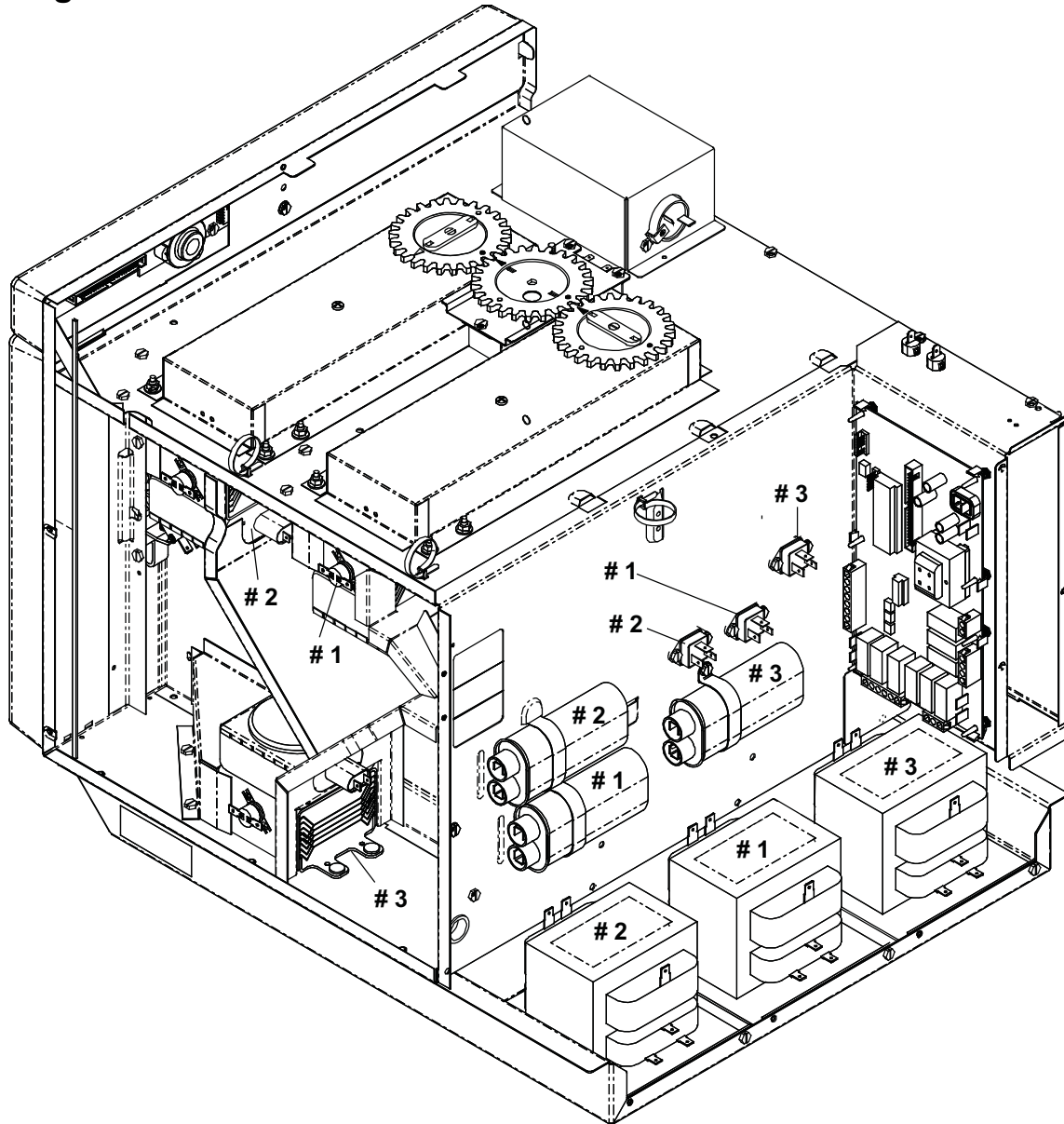

H.V. System # 1	H.V. System # 2	H.V. System # 3
Top Rear Magnetron Center Transformer Bottom Center Capacitor Diode Center Triac	Top Front Magnetron Left Transformer Top Left Capacitor Diode Left Triac	Bottom Magnetron Right Transformer Right Capacitor Diode Right Triac

Component Testing Procedures



WARNING

To avoid risk of electrical shock, personal injury or death; disconnect power to oven and discharge capacitor before servicing, unless testing requires power.

Two Magnetron Models

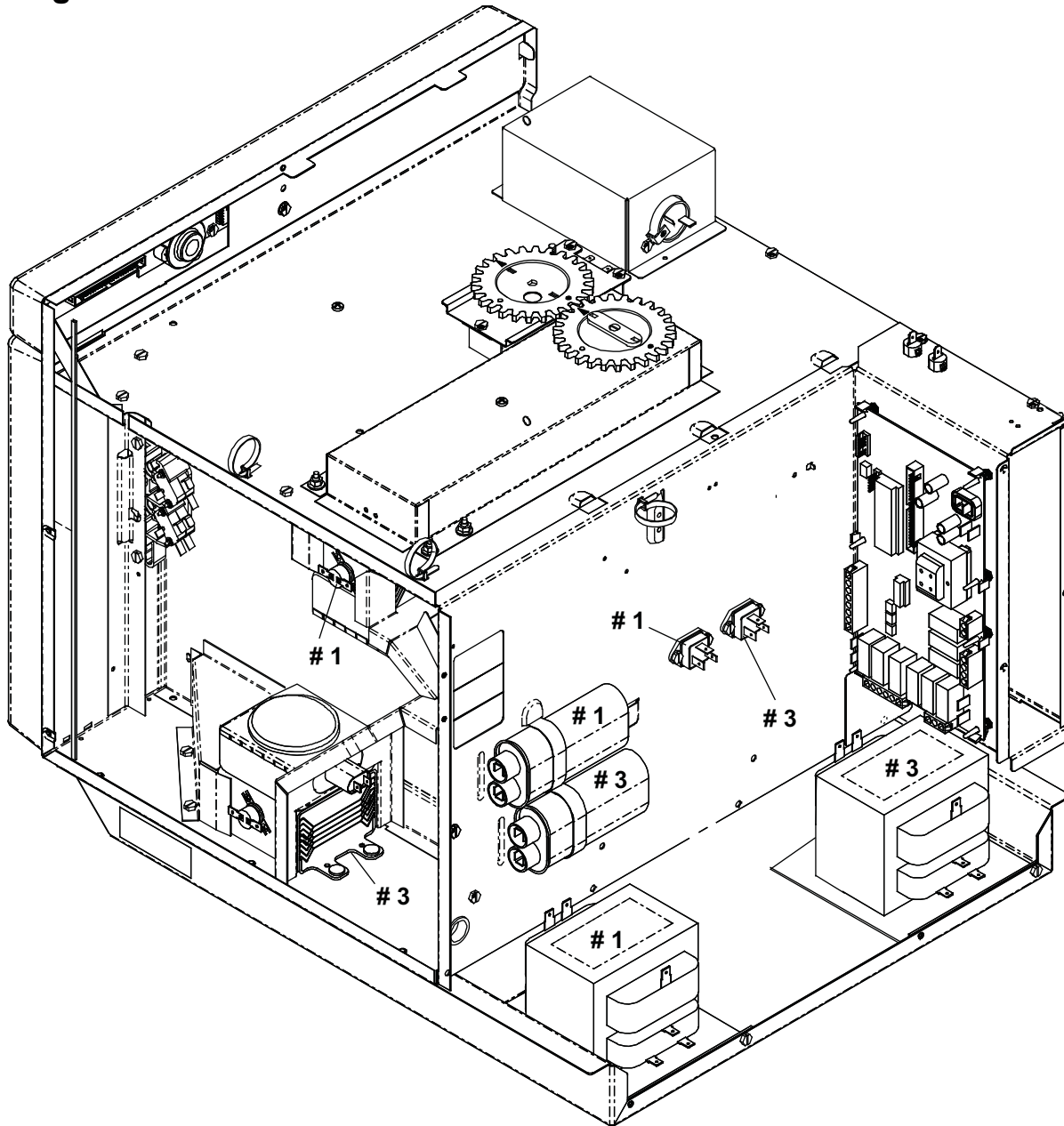

H.V. System # 1	H.V. System # 3
Top Rear Magnetron Left Transformer Top Capacitor Diode Left Triac	Bottom Magnetron Right Transformer Bottom Capacitor Diode Right Triac

Power Testing Procedure



WARNING

To avoid risk of electrical shock, personal injury or death; disconnect power to oven and discharge capacitor before servicing, unless testing requires power.

All Amana and Menumaster microwave oven power outputs are rated using the IEC705 standards. Using the IEC705 test method requires precision measurements and equipment that is not practical to be performed in the field. Using the test shown below will indicate if the oven performance is satisfactory.

Test equipment required:

- 1000 ml test container and thermometer (ACP power test bowl part # 12018801).
- Digital watch / watch with a second hand for use on ovens with electromechanical timers.

Important Notes:

- Low line voltage will cause low temperature rise / power output.
- Ovens must be on a dedicated circuit, properly grounded, and polarized. Other equipment on the same circuit may cause a low temperature rise / power output.
- This test and results are not a true IEC705 test procedure and are only intended to provide servicers with an easy means of determining if the microwave oven cooking output is correct.

Procedure

1. Fill the test container to the 1000 ml line with cool tap water.

NOTE: Water temperature should be approximately 60°F / 16°C

2. Using the thermometer, stir water for five to ten seconds; measure, and record the temperature (T1).
3. Place test container of water in the center of oven cavity and close door.
4. Heat the water for a 33-second full power cycle.

NOTE: Use a digital watch or a watch with a second hand for ovens with electromechanical timers.

5. At end of the cycle, remove test container. Using the thermometer, stir water for five to ten seconds and record temperature (T2).
6. Subtract the starting water temperature (T1), from the ending water temperature (T2) to obtain the temperature rise (ΔT).
7. If the temperature rise (ΔT) meets or exceeds the minimum, the test is complete. If the temperature rise (ΔT) fails to meet the minimum temperature rise, test the line voltage to verify it is correct. Then repeat steps 1 - 6 making sure to change the water. If the temperature rise (ΔT) fails to meet the minimum temperature rise again the oven will require service.

Minimum Temperature Rise at Thirty -Three (33) Seconds Run Time

ΔT (°F)	Cooking Power Output	ΔT (°F)	Cooking Power Output	ΔT (°C)	Cooking Power Output	ΔT (°C)	Cooking Power Output
10.....	1000	20	2000	5	1000	11	2000
11.....	1100	21	2100	5.5	1100	11.5	2100
12.....	1200	22	2200	6.5	1200	12	2200
14.....	1400	24	2400	7.5	1400	13	2400
17.....	1700	25	2500	9.5	1700	13.5	2500
18.....	1800	27	2700	10	1800	15	2700
19.....	1900	30	3000	10.5	1900	16.5	3000

Display Diagnostics



WARNING

To avoid risk of electrical shock, personal injury, or death, disconnect power to oven and discharge capacitor before servicing, unless testing requires power.



CAUTION

All repairs as described in this troubleshooting section are to be performed only after the caution procedures one through eight listed below have been followed.

1. Check grounding before checking for possible causes.
2. Be careful of the high voltage circuit.
3. Discharge high voltage capacitor.
4. When checking the continuity of the switches or the high voltage transformer, disconnect one lead wire from these parts and then check continuity with the AC plug removed. To do otherwise may result in a false reading or damage to your meter.
5. Do not touch any parts of the circuitry on the P.C. Board circuit since static electric discharge may damage this control panel. Always touch yourself to ground while working on this panel to discharge any static charge in your body.
6. 208/230 VAC is present in the high voltage circuit board, power relay and primary circuit of low voltage transformer.
7. When troubleshooting, be cautious of possible electrical hazard.

Error Codes

During operation, the display may show the following service codes:

NOTE: Before scheduling service for any error codes, instruct customer to unplug oven for 1 minute, reconnect power, and retest. If unit operates properly, no service call is required.

Display	Description	Corrective Action
Err1	Failed H.V. Board	Replace H.V. board.
Err2	Shorted Touch Panel Failed H.V. Board Shorted Display Board Shorted Cable HV to Display Board	Replace Touch Panel. Replace H.V. board. Replace Display Board. Replace Cable.
Err3	Failed H.V. Board	Replace H.V. board.
Err4	Failed H.V. Board	Replace H.V. board.
Err5	Shorted Touch Panel	NOTE: If Touch Panel is pressed for more than 30 seconds, this error code will appear. <ol style="list-style-type: none"> 1. Disconnect oven from power supply. 2. Disconnect side touch panel connector from display board (J5). 3. Reconnect oven to power supply. 4. If "Err5" reappears after 30 seconds, replace top touch panel. 5. If "Err5" does not reappear after 30 seconds, replace side touch panel.
Err6	Failed H.V. Board	Replace H.V. board.
HOT		<ul style="list-style-type: none"> • Open TCO (magnetron). • Blower motor inoperative. • Restricted air filter. • High ambient temperature. • Oven operated empty or with light loads. • Broken or loose wire. • H.V. board inoperative.
Door	Door Interlock Primary Switch	<ul style="list-style-type: none"> • Verify latch mechanism moves freely on door. • Verify J1 connector on display board is properly seated. • Test interlock switch assembly and perform door adjustment if necessary. • Replace interlock switch assembly.

Service Test

NOTE: Unit must be in OFF condition
or
INITIAL power up mode.

To Enter Service Test Mode, oven door must be closed.

NOTE: Pads will not beep when accessing Service Test Mode.
To EXIT Service Test Mode press STOP/RESET pad.

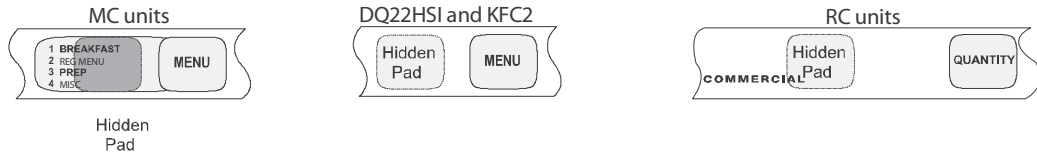

Mode Name	Service Mode																																								
Entry	Pressing Hidden Pad, 1, 3, 5, 7, 9 while in the ready mode:																																								
Functional Description	Main Service Mode Menu																																								
Display	<table border="1"> <tr> <td></td><td></td><td></td><td></td><td>S</td><td>e</td><td>r</td><td>v</td><td>i</td><td>c</td><td>e</td><td></td><td>M</td><td>o</td><td>d</td><td>e</td><td></td><td></td><td></td><td></td> </tr> <tr> <td></td><td></td><td></td><td></td><td>6</td><td>0</td><td></td><td></td><td>H</td><td>Z</td><td></td><td></td><td>2</td><td>0</td><td>8</td><td></td><td>V</td><td></td><td></td><td></td> </tr> </table>					S	e	r	v	i	c	e		M	o	d	e									6	0			H	Z			2	0	8		V			
				S	e	r	v	i	c	e		M	o	d	e																										
				6	0			H	Z			2	0	8		V																									

Pad 1

Mode Name	Service Pad 1																																								
Entry	Pressing Pad 1 while in Service Mode																																								
Functional Description	Magnetron #1 shall be toggled. When on, it shall run for 62 seconds.																																								
Display	<table border="1"> <tr> <td></td><td></td><td>M</td><td>a</td><td>g</td><td>n</td><td>e</td><td>t</td><td>r</td><td>o</td><td>n</td><td></td><td>#</td><td>1</td><td>:</td><td></td><td>O</td><td>N</td><td></td><td></td> </tr> <tr> <td></td><td></td><td>0</td><td>0</td><td>:</td><td>4</td><td>5</td><td></td><td></td><td></td><td>A</td><td>m</td><td>p</td><td>s</td><td>:</td><td></td><td>1</td><td>2</td><td></td><td></td> </tr> </table>			M	a	g	n	e	t	r	o	n		#	1	:		O	N					0	0	:	4	5				A	m	p	s	:		1	2		
		M	a	g	n	e	t	r	o	n		#	1	:		O	N																								
		0	0	:	4	5				A	m	p	s	:		1	2																								

Pad 2

Mode Name	Service Pad 2																																								
Entry	Pressing Pad 2 while in Service Mode																																								
Functional Description	Magnetron #2 shall be toggled. When on, it shall run for 62 seconds.																																								
Display	<table border="1"> <tr> <td></td><td></td><td>M</td><td>a</td><td>g</td><td>n</td><td>e</td><td>t</td><td>r</td><td>o</td><td>n</td><td></td><td>#</td><td>2</td><td>:</td><td></td><td>O</td><td>N</td><td></td><td></td> </tr> <tr> <td></td><td></td><td>0</td><td>0</td><td>:</td><td>4</td><td>5</td><td></td><td></td><td></td><td>A</td><td>m</td><td>p</td><td>s</td><td>:</td><td></td><td>1</td><td>2</td><td></td><td></td> </tr> </table> <p>Note: Not applicable on two magnetron models:</p>			M	a	g	n	e	t	r	o	n		#	2	:		O	N					0	0	:	4	5				A	m	p	s	:		1	2		
		M	a	g	n	e	t	r	o	n		#	2	:		O	N																								
		0	0	:	4	5				A	m	p	s	:		1	2																								

Pad 3

Mode Name	Service Pad 3																																								
Entry	Pressing Pad 3 while in Service Mode																																								
Functional Description	Magnetron #3 shall be toggled. When on, it shall run for 62 seconds.																																								
Display	<table border="1"> <tr> <td></td><td></td><td>M</td><td>a</td><td>g</td><td>n</td><td>e</td><td>t</td><td>r</td><td>o</td><td>n</td><td></td><td>#</td><td>3</td><td>:</td><td></td><td>O</td><td>N</td><td></td><td></td> </tr> <tr> <td></td><td></td><td>0</td><td>0</td><td>:</td><td>4</td><td>5</td><td></td><td></td><td></td><td>A</td><td>m</td><td>p</td><td>s</td><td>:</td><td></td><td>1</td><td>2</td><td></td><td></td> </tr> </table>			M	a	g	n	e	t	r	o	n		#	3	:		O	N					0	0	:	4	5				A	m	p	s	:		1	2		
		M	a	g	n	e	t	r	o	n		#	3	:		O	N																								
		0	0	:	4	5				A	m	p	s	:		1	2																								

Service Test

Pad 5

Mode Name	Service Pad 5																																								
Entry	Pressing Pad 5 while in Service Mode																																								
Functional Description	Auxiliary Output shall be toggled.																																								
Display																																									
<table border="1"> <tr> <td></td><td></td><td></td><td>A</td><td>u</td><td>x</td><td>.</td><td></td><td>O</td><td>u</td><td>t</td><td>p</td><td>u</td><td>t</td><td>:</td><td></td><td>O</td><td>N</td><td></td><td></td> </tr> <tr> <td></td><td></td><td></td><td></td><td></td><td></td><td></td><td></td><td></td><td></td><td></td><td></td><td></td><td></td><td></td><td></td><td></td><td></td><td></td><td></td> </tr> </table>					A	u	x	.		O	u	t	p	u	t	:		O	N																						
			A	u	x	.		O	u	t	p	u	t	:		O	N																								

Pad 7

Mode Name	Service Pad 7																																						
Entry	Pressing Pad 7 while in Service Mode																																						
Functional Description	Displays Tube Hours stored in EEPROM																																						
Display																																							
<table border="1"> <tr> <td></td><td></td><td>M</td><td>a</td><td>g</td><td>n</td><td>e</td><td>t</td><td>r</td><td>o</td><td>n</td><td></td><td>H</td><td>o</td><td>u</td><td>r</td><td>S</td><td></td><td></td> </tr> <tr> <td></td><td></td><td></td><td></td><td></td><td></td><td>0</td><td>0</td><td>1</td><td>7</td><td>4</td><td>3</td><td></td><td></td><td></td><td></td><td></td><td></td><td></td> </tr> </table>				M	a	g	n	e	t	r	o	n		H	o	u	r	S									0	0	1	7	4	3							
		M	a	g	n	e	t	r	o	n		H	o	u	r	S																							
						0	0	1	7	4	3																												

Pad 8

Mode Name	Service Pad 8																																				
Entry	Pressing Pad 8 while in Service Mode																																				
Functional Description	Displays Door Cycles stored in EEPROM. Will always be a multiple of ten.																																				
Display																																					
<table border="1"> <tr> <td></td><td></td><td></td><td></td><td>D</td><td>o</td><td>o</td><td>r</td><td></td><td>C</td><td>y</td><td>c</td><td>l</td><td>e</td><td>s</td><td></td><td></td><td></td> </tr> <tr> <td></td><td></td><td></td><td></td><td></td><td>0</td><td>0</td><td>2</td><td>4</td><td>5</td><td>3</td><td>8</td><td>0</td><td></td><td></td><td></td><td></td><td></td> </tr> </table>						D	o	o	r		C	y	c	l	e	s									0	0	2	4	5	3	8	0					
				D	o	o	r		C	y	c	l	e	s																							
					0	0	2	4	5	3	8	0																									

Pad 9

Mode Name	Service Pad 9																																				
Entry	Pressing Pad 9 while in Service Mode																																				
Functional Description	Prompts user to clear service information.																																				
Display																																					
<table border="1"> <tr> <td></td><td></td><td>P</td><td>r</td><td>e</td><td>s</td><td>s</td><td></td><td>S</td><td>T</td><td>A</td><td>R</td><td>T</td><td></td><td>t</td><td>o</td><td></td><td></td> </tr> <tr> <td></td><td></td><td>C</td><td>l</td><td>e</td><td>a</td><td>r</td><td></td><td>s</td><td>e</td><td>r</td><td>v</td><td>.</td><td></td><td>i</td><td>n</td><td>f</td><td>o</td> </tr> </table>				P	r	e	s	s		S	T	A	R	T		t	o					C	l	e	a	r		s	e	r	v	.		i	n	f	o
		P	r	e	s	s		S	T	A	R	T		t	o																						
		C	l	e	a	r		s	e	r	v	.		i	n	f	o																				

Wiring Diagram and Schematic



WARNING

To avoid risk of electrical shock, personal injury or death; disconnect power to oven and discharge capacitor before servicing, unless testing requires power.

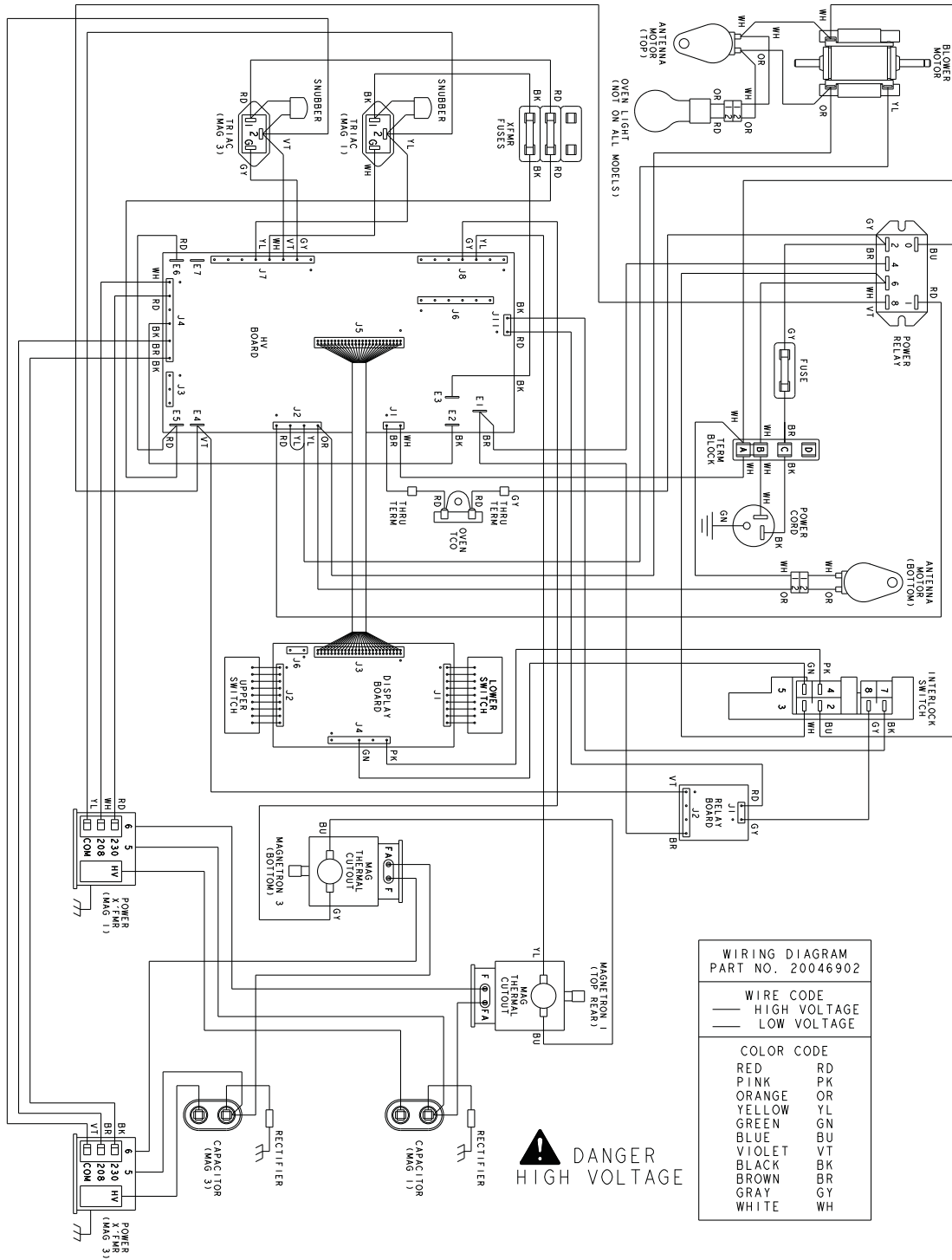

⚠ DANGER HIGH VOLTAGE

20046902

DQ22HSI2 RC17S2 MRC17S2 RC17SDOSI RC22S2 WDYRC22

Wiring Diagram and Schematic



WARNING

To avoid risk of electrical shock, personal injury or death; disconnect power to oven and discharge capacitor before servicing, unless testing requires power.

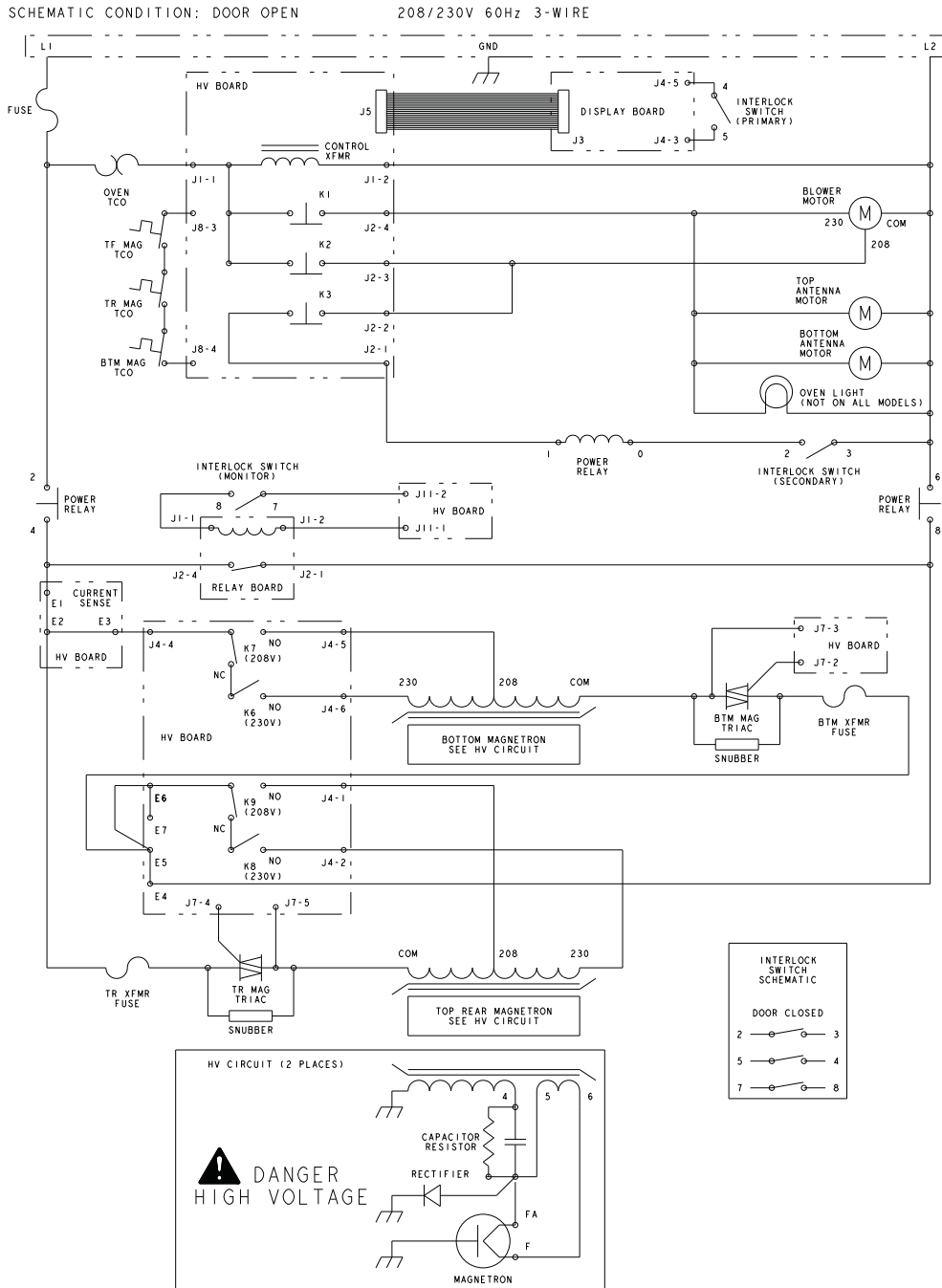

20046901



DANGER

HIGH VOLTAGE

DQ22HSI2 RC17S2 MRC17S2 RC17SDOSI RC22S2 WDYRC22

Wiring Diagram and Schematic



WARNING

To avoid risk of electrical shock, personal injury or death; disconnect power to oven and discharge capacitor before servicing, unless testing requires power.

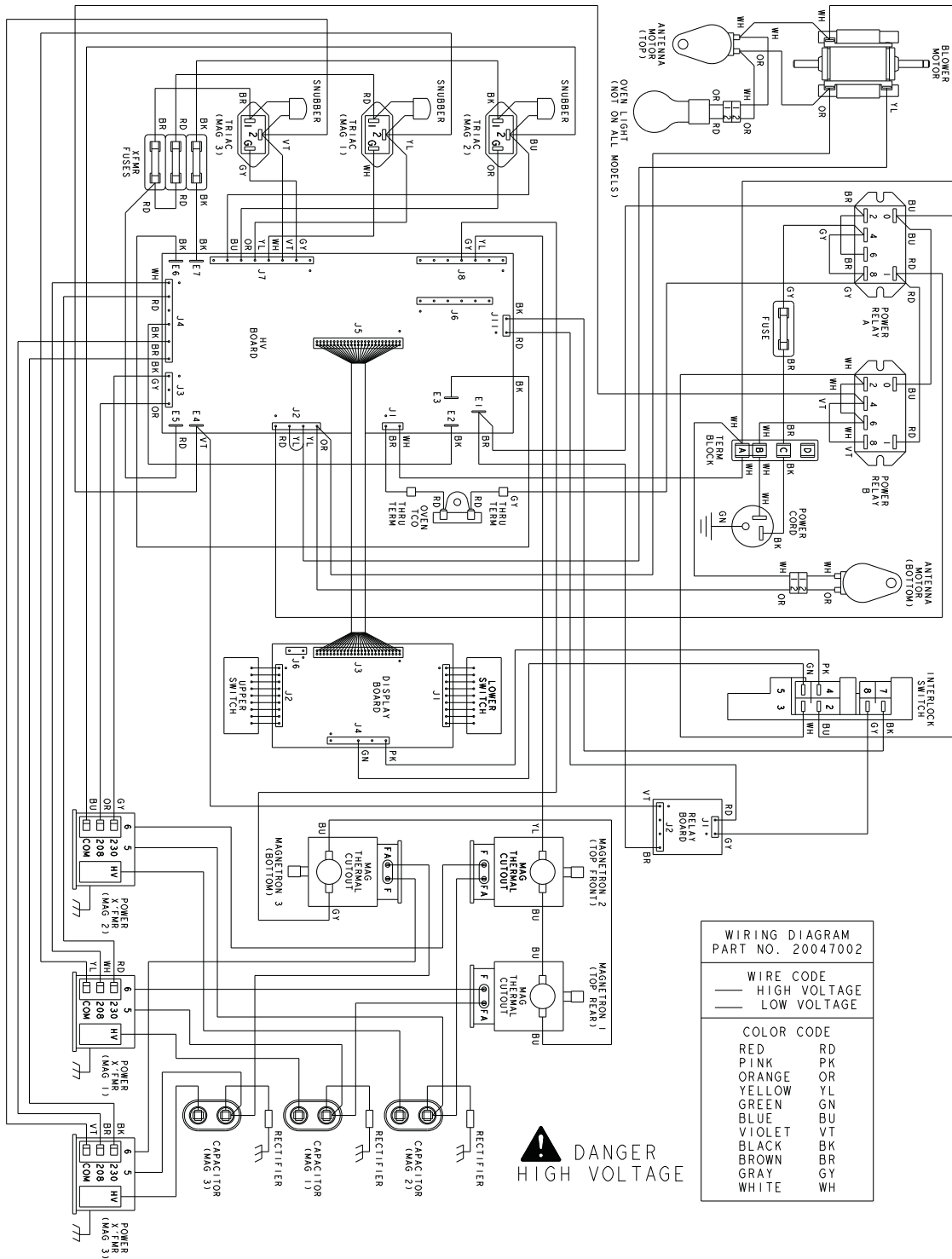

⚠ DANGER HIGH VOLTAGE

20047002

KFC2W2 MC23MPW2 MC23MPTW2 RC30S2 MRC30S2

Wiring Diagram and Schematic



WARNING

To avoid risk of electrical shock, personal injury or death; disconnect power to oven and discharge capacitor before servicing, unless testing requires power.

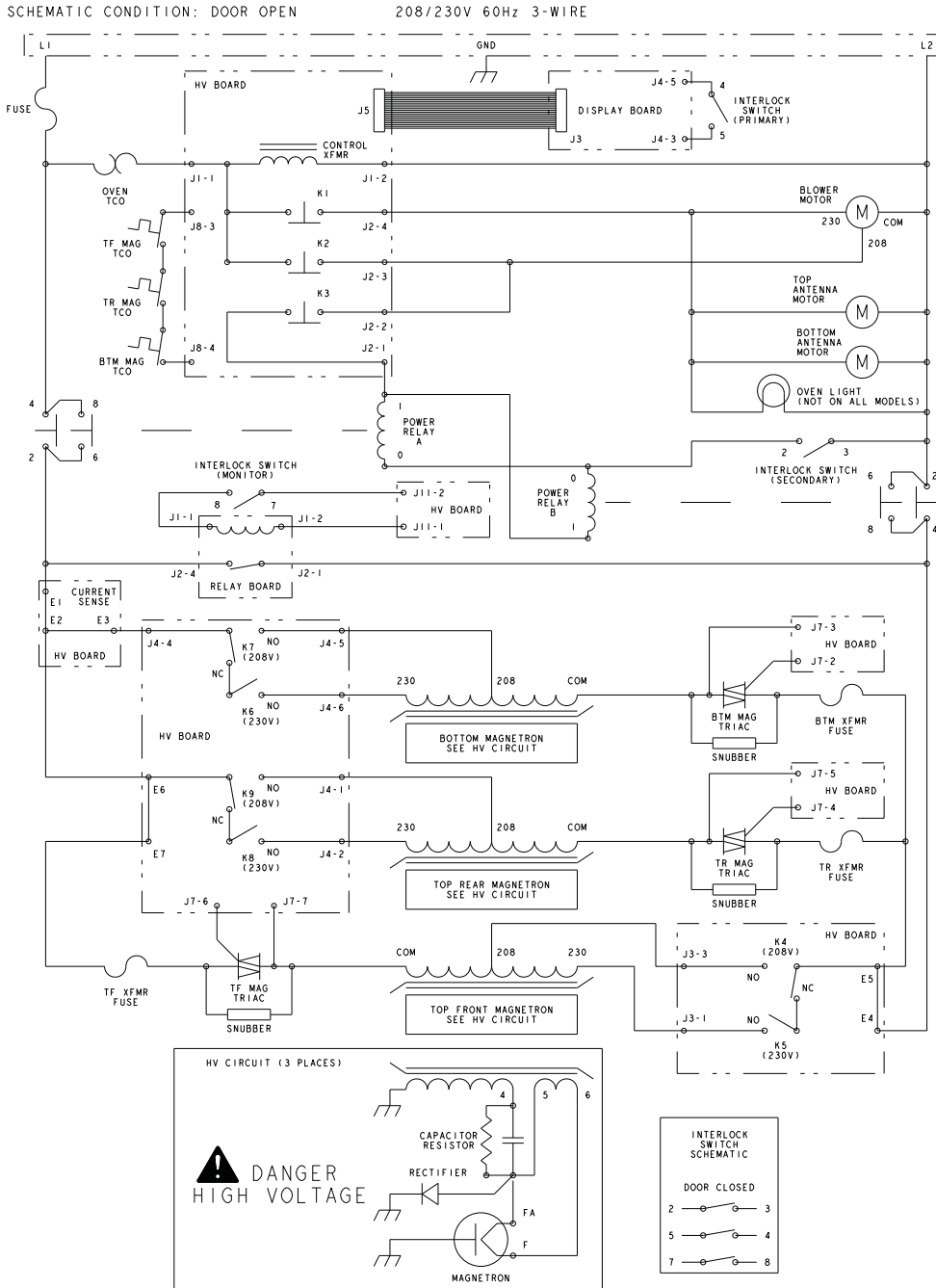

20047001



KFC2W2 MC23MPW2 MC23MPTW2 RC30S2 MRC30S2