

Commercial Microwave-Technical Information

120 VAC, 60 Hz model

RCS10TS
MCS10TS

P2001101M
P2001103M

- Due to possibility of personal injury or property damage, always contact an authorized technician for servicing or repair of this unit.
- Refer to Service Manual for installation, operating, testing, troubleshooting, and disassembly instruction.



CAUTION

All safety information must be followed as provided in Service Manual.



WARNING





To avoid the risk of electrical shock, personal injury or death; disconnect power to oven and discharge capacitor before servicing, unless testing requires power.

Models	RCS10TS / MCS10TS	
Power Source		
Voltage AC	120 VAC	
Amperage (Single Unit)	15 A	
Frequency	60 Hz	
Single Phase, 3 wire grounded	X	
Receptacle	5-15R	
Plug	5-15P	
Power Output – Microwave		
Nominal microwave energy (IEC705)	1000 Watts	
Minimum temperature rise (ΔT)	10°F / 5°C	
Operating Frequency	2450 MHz	
Power Consumption		
Microwave only	1500 Watts	
Dimensions		
Cabinet (in cm)		
Width	22"	56 cm
Height	13 3/4"	34.4 cm
Depth	19"	37.9 cm
Oven Interior (in cm)		
Width	14 1/2"	36.8 cm
Height	8 1/2"	21.6 cm
Depth	15 "	38.1 cm
Weight		
Uncrated	41 lbs.	18.6 kg
Features		
Timer	60 minute	
Power Selection	5 Levels	
Cavity Volume	1.2 cu. Ft.	

Component Testing Procedures

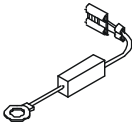
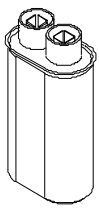
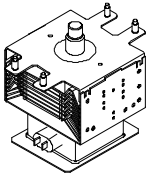
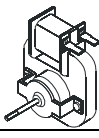
⚠ WARNING

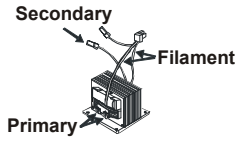
To avoid risk of electrical shock, personal injury or death; disconnect power to oven and discharge capacitor before servicing, unless testing requires power.

Illustration	Component	Testing	Results
	Thermal cutout	Disconnect all wires from TCO. Measure resistance across terminals. Cavity TCO Magnetron TCO	Closed at 122°F (50°C) and Opens at 185°F (85°C) Closed at 249°F (115°C) and Opens at 320°F (160°C)
	Diode	Discharge Capacitor Remove diode lead from capacitor and connect ohmmeter. Reverse leads for second test.	Infinite resistance should be measured in one direction and 50KΩ or more in the opposite direction. NOTE: Ohmmeter must contain a battery of 6 volts minimum.
	Capacitor	Discharge Capacitor Remove wires from capacitor terminals and connect ohmmeter, set on highest resistance scale to terminals. Also check between each terminal and capacitor case.	Between Terminals: Meter should momentarily deflect towards zero then return to over 5 MΩ. If no deflection occurs, or if continuous deflection occurs, replace capacitor. Terminal to Case: Infinite resistance
	Magnetron	Discharge Capacitor Remove wires from magnetron and connect ohmmeter to terminals. Also check between each terminal and ground.	Between Terminals: Less than 1 Ω Each terminal to ground measures Infinite resistance. Note: This test is not conclusive. If oven does not heat and all other components test good replace the magnetron and retest.
	Blower motor	Remove all wires from motor. Measure resistance across coil	Approximately 44 Ω
	Stirrer motor	Remove all wires from motor. Measure resistance across terminals	Approximately 3.8K Ω
	Transformer	Discharge Capacitor Remove all wires from terminals. Measure resistance from: Primary Filament..... Secondary to Ground screw on transformer stack.....	Less than <1 Ω Less than <1 Ω Approximately 90 Ω
	Lamp and receptacle	Test continuity of receptacle terminals.	Indicates continuity with bulb installed.
	Wire Harness	Test continuity of wires	Indicates continuity

Component Testing Procedures



WARNING

To avoid risk of electrical shock, personal injury or death; disconnect power to oven and discharge capacitor before servicing, unless testing requires power.

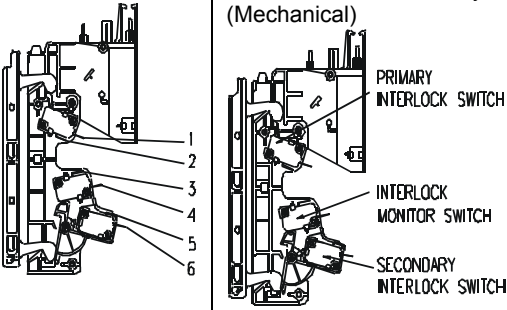
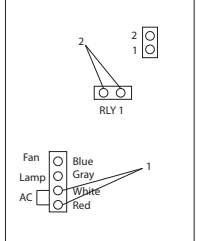
Illustration	Component	Testing	Results
	Fuse block / Filter assembly	Power In terminals Power Out terminals.....	120 VAC 120 VAC If no power in, check power outlet If no power out, check fuses
	Interlock switch assembly (Mechanical)	Disconnect wires to switch. With door open measure resistance from: Monitor – Terminals 3 - 4 Primary – Terminals 1 - 2 Secondary – Terminals 5 - 6..... With door closed measure resistance from: Monitor – Terminals 3 - 4 Primary – Terminals 1 - 2 Secondary – Terminals 5 - 6..... After verifying or replacing the module, re-connect wires to switch and check operation of monitor circuit before operating the oven.	Indicates continuity Infinite Ω Infinite Ω Infinite Ω Indicates continuity Indicates continuity
	Electronic control board	<ol style="list-style-type: none"> (4 pin connector) Measure voltage at red white leads..... (Relay 1) Measure voltage across red and white terminals leads..... 	Approximately 120 VAC 120 VAC OFF position (Door Closed) 0 volts Cook mode (Door Closed)

Power Test



WARNING

To avoid risk of electrical shock, personal injury or death; disconnect power to oven and discharge capacitor before servicing, unless testing requires power.

All microwave oven power outputs are rated using the IEC705 standards. Using the IEC705 test method requires precision measurements and equipment that is not practical to be performed in the field. Using the test shown below will indicate if the oven performance is satisfactory.

Test equipment required:

- 1000 ml test container and thermometer
- Digital watch / watch with a second hand for use on ovens with electromechanical timers.

Important Notes:

- Low line voltage will cause low temperature rise / power output.
- Ovens must be on a dedicated circuit, properly grounded, and polarized. Other equipment on the same circuit may cause a low temperature rise / power output.
- This test and results are not a true IEC705 test procedures and are only intended to provide servicers with an easy means of determining if the microwave oven cooking output is correct.

Procedure

1. Fill the test container to the 1000 ml line with cool tap water.

NOTE: Water temperature should be approximately 60°F / 16°C

2. Using the thermometer, stir water for five to ten seconds; measure, and record the temperature (T1).
3. Place test container of water in the center of oven cavity and close door.
4. Heat the water for a 33-second full power cycle.

NOTE: Use a digital watch or a watch with a second hand for ovens with electromechanical timers.

5. At end of the cycle, remove test container. Using the thermometer, stir water for five to ten seconds and record temperature (T2).
6. Subtract the starting water temperature (T1) from the ending water temperature (T2) to obtain the temperature rise (ΔT).
7. If the temperature rise (ΔT) meets or exceeds the minimum, the test is complete. If the temperature rise (ΔT) fails to meet the minimum temperature rise, test the line voltage to verify it is correct. Then repeat steps 1 - 6 making sure to change the water. If the temperature rise (ΔT) fails to meet the minimum temperature rise again the oven will require service.

Minimum Temperature Rise at Thirty -Three (33) Seconds Run Time

ΔT (°F)	Cooking Power Output	ΔT (°F)	Cooking Power Output	ΔT (°C)	Cooking Power Output	ΔT (°C)	Cooking Power Output
10	1000	20	2000	5	1000	11	2000
11	1100	21	2100	5.5	1100	11.5	2100
12	1200	22	2200	6.5	1200	12	2200
14	1400	24	2400	7.5	1400	13	2400
17	1700	25	2500	9.5	1700	13.5	2500
18	1800	27	2700	10	1800	15	2700
19	1900	30	3000	10.5	1900	16.5	3000

Wiring Diagram and Schematic



WARNING

To avoid risk of electrical shock, personal injury or death; disconnect power to oven and discharge capacitor before servicing, unless testing requires power.

