

# Commercial Microwave—Technical Information

## 208/230 V, 60 Hz Models

<b>HDC182</b>	<b>P2001503M</b>	<b>MDC182</b>	<b>P2001504M</b>
<b>HDC18SD2</b>	<b>P2001505M</b>	<b>CRC18T2OG2</b>	<b>P2001506M</b>
<b>HDC212</b>	<b>P2001507M</b>	<b>MDC212</b>	<b>P2001508M</b>
<b>HDC21RB2</b>	<b>P2001509M</b>	<b>HDC21RT2</b>	<b>P2001510M</b>
<b>MCHDC21</b>	<b>P2001512M</b>	<b>HDC21DQ</b>	<b>P2001511M</b>
<b>CRC21T2RLPF</b>	<b>P2001513M</b>		

Due to possibility of personal injury or property damage, always contact an authorized technician for servicing or repair of this unit.

- Refer to Service Manual for installation, operating, testing, troubleshooting, and disassembly instruction.

 <b>CAUTION</b> All safety information must be followed as provided in Service Manual.
--

 <b>WARNING</b> To avoid the risk of electrical shock, personal injury or death, disconnect power to oven and discharge capacitor before servicing, unless testing requires power.
--

Models	HDC182, MDC182 HDC18SD2, CRC18T2OG2	HDC212,HDC21DQ, MDC212 HDC21RB2, MCHDC21 HDC21RT2, CRC21T2RLPF
<b>Power Source</b>		
Voltage AC	230/208 VAC	230/208 VAC
Amperage (Single Unit)	20 A	20 A
Frequency	60 Hz	60 Hz
Single Phase, 3 wire grounded	X	X
Receptacle	6-20R	6-20R
Plug	6-20P	6-20P
<b>Power Output</b>		
Nominal microwave energy (IEC705)	1800 Watts	2100 Watts
Minimum temperature rise ( $\Delta T$ )	18° F / 10° C	21° F / 11.5° C
Operating Frequency	2450 MHz	2450 MHz
<b>Power Consumption</b>		
Cook Condition Microwave	3450 Watts	3450 Watts
<b>Dimensions</b>		
<b>Cabinet</b>		
Width	16 5/8"	16 5/8"
Height	13 3/16"	13 3/16"
Depth	21 9/16"	21 9/16"
<b>Oven Interior</b>		
Width	13"	13"
Height	6 7/8"	6 7/8"
Depth	12"	12"
<b>Weight</b>		
Crated	74 lbs.	74 lbs.
Uncrated	68 lbs.	68 lbs.

# Component Testing Procedures

## ⚠ WARNING

To avoid risk of electrical shock, personal injury or death, disconnect power to oven and discharge capacitor before servicing, unless testing requires power.

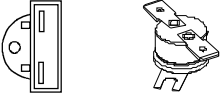
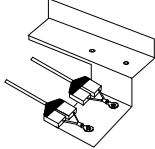
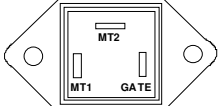
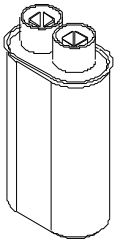
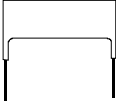
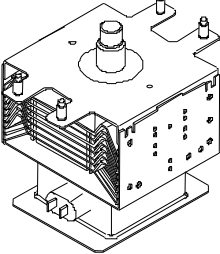
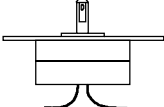
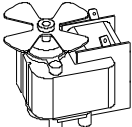
Illustration	Component	Test	Results
	Thermal Cutout	Disconnect all wires from TCO. Measure resistance across terminals. Cavity Thermal Fuse..... Magnetron TCO.....	Open at 219° F (104° C). Open at 280° F (138° C) and closed at 180° F (82° C).
	Diode Assembly	<b>Discharge Capacitors</b>  Remove diode lead from capacitor and connect ohmmeter.  Reverse leads for second test.	Infinite resistance should be measured in one direction and 50KΩ or more in the opposite direction.  <b>NOTE:</b> Test meter must contain a battery of 6 volts minimum.
	Triac	Disconnect wires to triac.  Measure resistance from: MT1 to MT2 ..... MT1 to Gate..... MT2 to Gate..... All terminals to ground.....	<b>Caution - Do not operate oven with wire to terminal MT2 removed.</b>  Infinite. Approximately 40 Ω or more. Infinite. Infinite.
	Capacitor	<b>Discharge Capacitors</b>  Remove wires from capacitor terminals and connect ohmmeter, set on highest resistance scale to terminals.  Also check between each terminal and capacitor case.	<b>Between Terminals:</b> Meter should momentarily deflect towards zero then return to over 5 MΩ. If no deflection occurs, or if continuous deflection occurs, replace capacitor.  <b>Terminal to Case:</b> Infinite resistance.
	Snubber Assembly	Disconnect wires to snubber.  Measure resistance across terminals.....	Infinite.
	Magnetron	<b>Discharge Capacitors</b>  Remove wires from magnetron and connect ohmmeter to terminals. Also check between each terminal and ground.	<b>Between Terminals:</b> Less than 1 Ω.  Each terminal to ground measures Infinite resistance. <b>NOTE:</b> This test is not conclusive. If oven does not heat and all other components test good replace the magnetron and retest.
	Stirrer Motor	Remove all wires from terminals.  Measure resistance from: Terminal to terminal.....	Approximately 25 KΩ.
	Blower Motor	Remove all wires from motor.  Measure resistance from White – Orange... Measure resistance from White – Yellow.....	Approximately 30 Ω. Approximately 30 Ω.

# Component Testing Procedures

## ⚠ WARNING

To avoid risk of electrical shock, personal injury or death, disconnect power to oven and discharge capacitor before servicing, unless testing requires power.

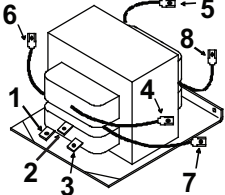
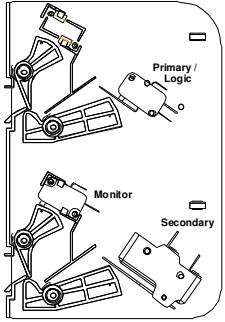
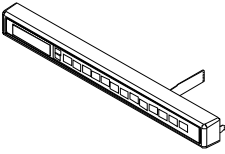
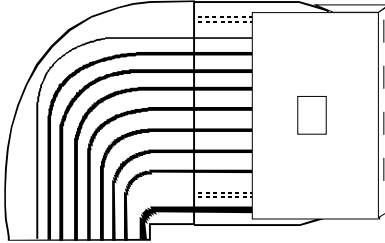
Illustration	Component	Test	Results																																																
 <p>Terminal 1 – Common Terminal 2 – 208 V Terminal 3 – 230 V</p>	Transformer	<p><b>Discharge Capacitors</b> Remove all wires from terminals. Measure resistance from:</p> <p>Terminal 1 to 2 ..... Less than 1 Ω Terminal 1 to 3 ..... Less than 1 Ω Terminal 5 to 6 ..... Less than 1 Ω Terminal 7 to 8 ..... Less than 1 Ω Terminal 4 to Ground screw... 30 Ω. Terminal 4 to any other terminal..... Infinite resistance. If not, replace transformer.</p> <p style="text-align: center;"><b>Violet</b> 2 ■■■ 1 ■■■ 3 ■■■ Gray Red</p>																																																	
	Interlock switch assembly	<p>Disconnect wires to switch.</p> <p>With door open measure resistance from:</p> <p>Terminal C to NC Monitor ..... Continuity. Terminal C to NO Primary / Logic ..... Infinite. Terminal C to NO Secondary ..... Infinite.</p> <p>With door closed measure resistance from:</p> <p>Terminal C to NC Monitor ..... Infinite. Terminal C to NO Primary / Logic ..... Continuity. Terminal C to NO Secondary ..... Continuity.</p> <p style="text-align: center;"><b>Door Closed</b></p> <p><b>Primary / Logic</b> C ● ● NO <b>Monitor</b> C ● ● NC <b>Secondary</b> C ● ● NO</p>																																																	
	Touch Panel Assembly	<p>Continuity is indicated as 100 Ω and below.</p> <p><b>Pin 1: Ground.</b></p> 	<table border="1"> <thead> <tr> <th>Pad</th> <th>Pins</th> <th>Measurement</th> </tr> </thead> <tbody> <tr><td>1</td><td>8 &amp; 10</td><td>Continuity</td></tr> <tr><td>2</td><td>7 &amp; 10</td><td>Continuity</td></tr> <tr><td>3</td><td>6 &amp; 10</td><td>Continuity</td></tr> <tr><td>4</td><td>5 &amp; 10</td><td>Continuity</td></tr> <tr><td>5</td><td>4 &amp; 10</td><td>Continuity</td></tr> <tr><td>6</td><td>3 &amp; 10</td><td>Continuity</td></tr> <tr><td>7</td><td>8 &amp; 9</td><td>Continuity</td></tr> <tr><td>8</td><td>7 &amp; 9</td><td>Continuity</td></tr> <tr><td>9</td><td>6 &amp; 9</td><td>Continuity</td></tr> <tr><td>0</td><td>5 &amp; 9</td><td>Continuity</td></tr> <tr><td>Start</td><td>4 &amp; 9</td><td>Continuity</td></tr> <tr><td>Stop/Reset</td><td>4 &amp; 8</td><td>Continuity</td></tr> <tr><td>Power Level</td><td>5 &amp; 8</td><td>Continuity</td></tr> <tr><td>X 2</td><td>6 &amp; 8</td><td>Continuity</td></tr> <tr><td>Time Entry</td><td>7 &amp; 8</td><td>Continuity</td></tr> </tbody> </table>	Pad	Pins	Measurement	1	8 & 10	Continuity	2	7 & 10	Continuity	3	6 & 10	Continuity	4	5 & 10	Continuity	5	4 & 10	Continuity	6	3 & 10	Continuity	7	8 & 9	Continuity	8	7 & 9	Continuity	9	6 & 9	Continuity	0	5 & 9	Continuity	Start	4 & 9	Continuity	Stop/Reset	4 & 8	Continuity	Power Level	5 & 8	Continuity	X 2	6 & 8	Continuity	Time Entry	7 & 8	Continuity
Pad	Pins	Measurement																																																	
1	8 & 10	Continuity																																																	
2	7 & 10	Continuity																																																	
3	6 & 10	Continuity																																																	
4	5 & 10	Continuity																																																	
5	4 & 10	Continuity																																																	
6	3 & 10	Continuity																																																	
7	8 & 9	Continuity																																																	
8	7 & 9	Continuity																																																	
9	6 & 9	Continuity																																																	
0	5 & 9	Continuity																																																	
Start	4 & 9	Continuity																																																	
Stop/Reset	4 & 8	Continuity																																																	
Power Level	5 & 8	Continuity																																																	
X 2	6 & 8	Continuity																																																	
Time Entry	7 & 8	Continuity																																																	
Wire Harness		Test continuity of wires.....	Continuity.																																																



# Component Testing Procedures

## ⚠ WARNING

To avoid risk of electrical shock, personal injury or death, disconnect power to oven and discharge capacitor before servicing, unless testing requires power.

### Conditions

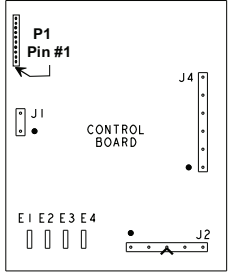
- Initial Power Up Condition:** Apply power to oven with door closed.
- Idle Condition:** Oven plugged in, display blank (no other components operating).
- Standby Condition:** Open oven door, light and motors operate.
- Cook Condition:** Food load in oven, cook cycle initiated.

Illustration	Component	Test	Results
	Controller board    <b>P1 connector used for touch panel ribbon</b>	<b>All Models</b> Line voltage to control board E1 (RD) —T1 (BK) triac ..... Output drive voltage to triac Triac terminals ..... Gate (BR) —T1 (BK) ..... <b>208 VAC line voltage</b> Fan relay (controls blower motor, antenna motor(s), and oven light) Control board ..... Terminals T1 (BK) —J2-3 (RD) ..... Line voltage sensing relay (automatically switches for 208 or 230 VAC operation) Control board ..... Terminals E1 (RD)—E2 (VT) ..... <b>230 VAC line voltage</b> Fan relay (controls blower motor, antenna motor(s), and oven light) Control board ..... Terminals T1 (BK) —J2-3 (RD) ..... Line voltage sensing relay (automatically switches for 208 or 230 VAC operation) Control board ..... Terminals E1 (RD) —E4 (PK) .....	Line voltage (All Conditions)  0 VAC (Idle and Standby) 0.2 VAC (Cook)  Line voltage (Idle) 0 VAC (Standby and Cook)  Line voltage (Idle) 0 volts (Standby and Cook)  Line voltage (Idle) 0 VAC (Standby and Cook)  Line voltage (Idle) 0 volts (Standby and Cook)

# Component Testing Procedures



## WARNING

To avoid risk of electrical shock, personal injury or death, disconnect power to oven and discharge capacitor before servicing, unless testing requires power.

All Amana and Menumaster microwave oven power outputs are rated using the IEC705 standards. Using the IEC705 test method requires precision measurements and equipment that is not practical to be performed in the field. Using the test shown below will indicate if the oven performance is satisfactory.

### Test equipment required:

- 1000 ml test container and thermometer.
- Digital watch / watch with a second hand for use on ovens with electromechanical timers.

### Important Notes:

- Low line voltage will cause low temperature rise / power output.
- Ovens must be on a dedicated circuit, properly grounded, and polarized. Other equipment on the same circuit may cause a low temperature rise / power output.
- This test and results are not a true IEC705 test procedure and are only intended to provide servicers with an easy means of determining if the microwave oven cooking output is correct.

### Procedure

1. Fill the test container to the 1000 ml line with cool tap water.

**NOTE:** Water temperature should be approximately 60°F / 16°C.

2. Using the thermometer, stir water for five to ten seconds; measure, and record the temperature (T1).
3. Place test container of water in the center of oven cavity and close door.
4. Heat the water for a 33-second full power cycle.

**NOTE:** Use a digital watch or a watch with a second hand for ovens with electromechanical timers.

5. At end of the cycle, remove test container. Using the thermometer, stir water for five to ten seconds and record temperature (T2).
6. Subtract the starting water temperature (T1), from the ending water temperature (T2) to obtain the temperature rise ( $\Delta T$ ).
7. If the temperature rise ( $\Delta T$ ) meets or exceeds the minimum, the test is complete. If the temperature rise ( $\Delta T$ ) fails to meet the minimum temperature rise, test the line voltage to verify it is correct. Then repeat steps 1 - 6 making sure to change the water. If the temperature rise ( $\Delta T$ ) fails to meet the minimum temperature rise again the oven will require service.

**Minimum Temperature Rise at Thirty -Three (33) Seconds Run Time**

$\Delta T$ (°F)	Cooking Power Output	$\Delta T$ (°F)	Cooking Power Output	$\Delta T$ (°C)	Cooking Power Output	$\Delta T$ (°C)	Cooking Power Output
10.....	1000	20 .....	2000	5 .....	1000	11 .....	2000
11.....	1100	21 .....	2100	5.5 .....	1100	11.5 .....	2100
12.....	1200	22 .....	2200	6.5 .....	1200	12 .....	2200
14.....	1400	24 .....	2400	7.5 .....	1400	13 .....	2400
17.....	1700	25 .....	2500	9.5 .....	1700	13.5 .....	2500
18.....	1800	27 .....	2700	10 .....	1800	15 .....	2700
19.....	1900	30 .....	3000	10.5 .....	1900	16.5 .....	3000

# Wiring and Schematic Diagrams

## **WARNING**

To avoid risk of electrical shock, personal injury or death, disconnect power to oven and discharge capacitor before servicing, unless testing requires power.

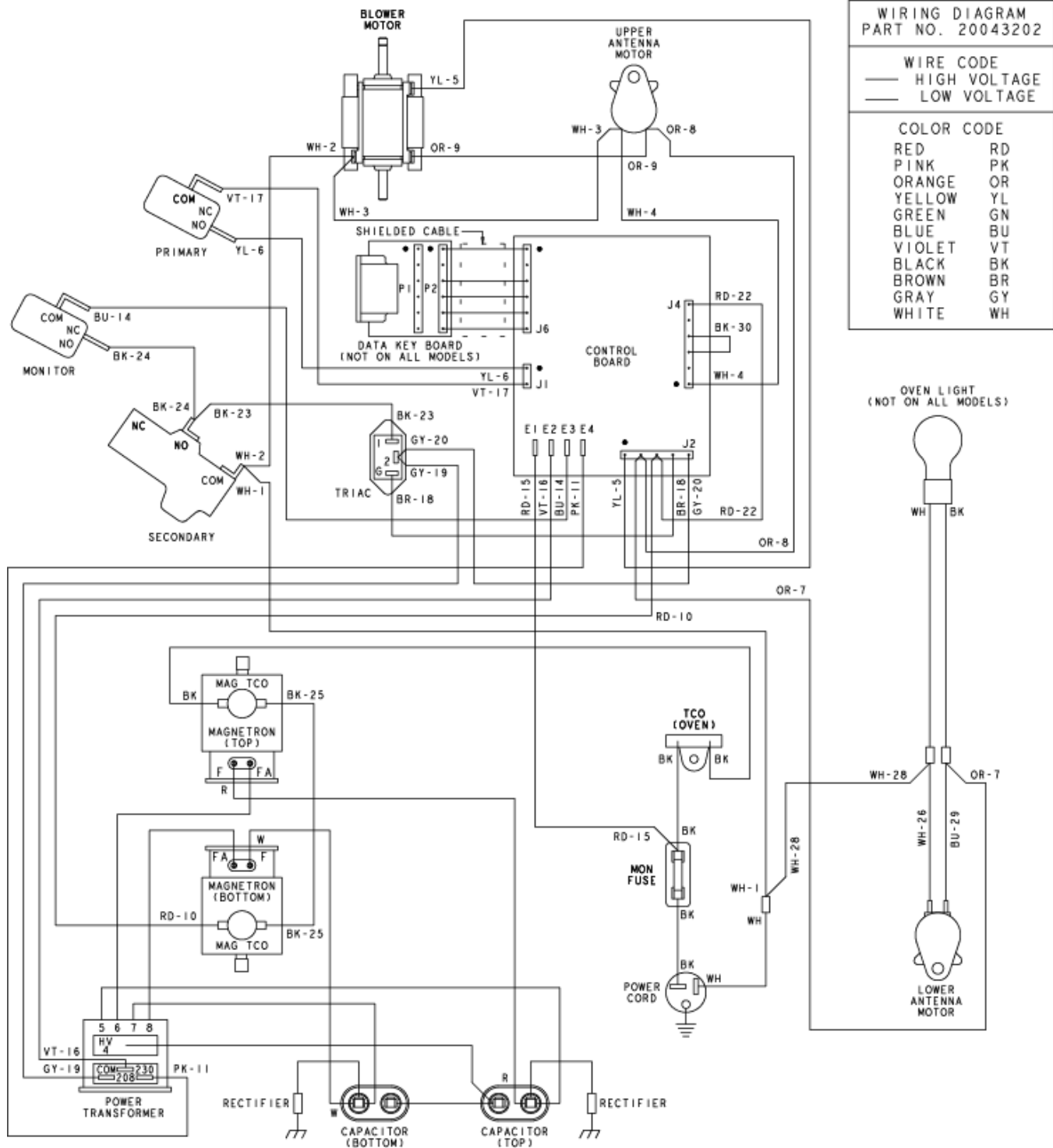

# Wiring and Schematic Diagrams



**WARNING**

To avoid risk of electrical shock, personal injury or death, disconnect power to oven and discharge capacitor before servicing, unless testing requires power.

208/230V 60HZ  
3-WIRE

SCHEMATIC  
CONDITION:  
DOOR OPEN

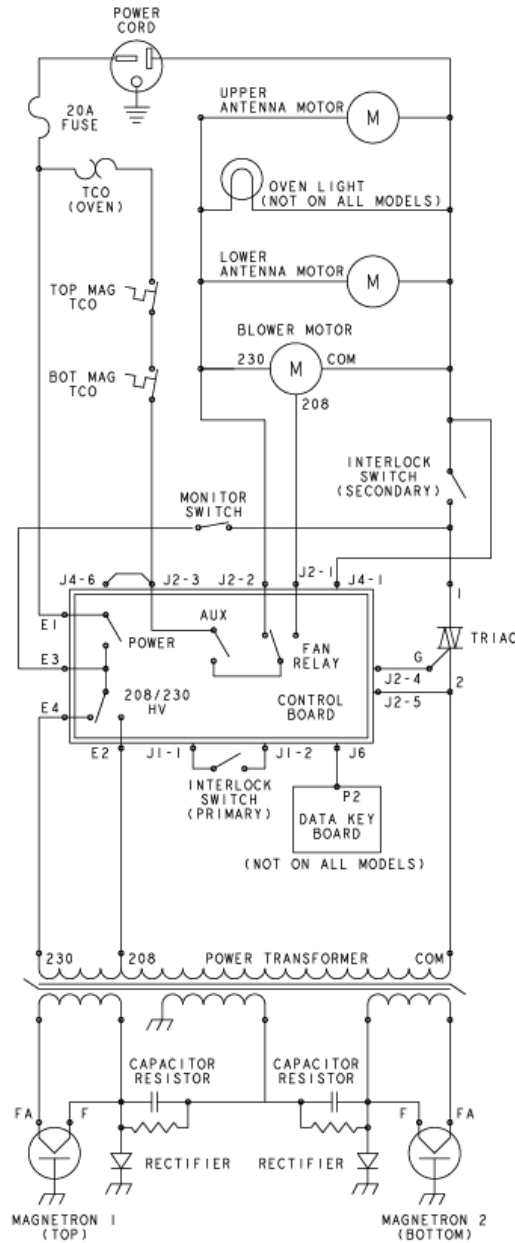
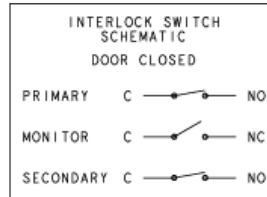

20043202



**DANGER**

**HIGH VOLTAGE**