

# MENUMASTER® Commercial

## Dairy Queen Boosting Oven



Designed exclusively for Dairy Queen, this proprietary oven is versatile, durable and easy to operate.

All ACP, Inc. commercial ovens are backed by our Culinary Center. Call us with any question regarding food preparation, menu development and cooking times 866-426-2621.



## Heavy Volume Menumaster Commercial Model DQ22HS12

### Power Output

- 2200 watts of power.
- 11 power levels for consistent, delicious results for frozen, refrigerated and fresh foods.
- Unique method of energy distribution provides superior even heating throughout the cavity.

### Easy to Use

- Menu codes and boost heat times are preprogrammed for simplified and consistent cooking results.
- Up to 400 programmable menu items and 11 power levels provide time saving food preparation and quality results.
- Flexible multi-programming capability for one-touch operation. Reduces prep time, labor and food waste while providing consistent results.
- Controls are user friendly and require minimal training.
- Multiple quantity pad calculates the proper cook times for multiple items.
- Automatic Voltage Sensor accommodates 208 and 240 volts allowing easy installation.
- Ample 1.0 cubic ft. (28 liter) capacity accommodates single or multiple servings.
- Interior ceramic shelf is sealed and recessed to reduce plate-to-shelf edge impact and keep spills contained.
- Stackable to save valuable counter space.

### Easy to Maintain

- Stainless steel exterior and interior for easy cleaning and a professional look.
- Constructed to withstand the foodservice environment.
- Removable, cleanable air filter and clean filter reminder protects oven components.
- Removable splatter shield cleans easily.
- Full 3 year warranty.
- Backed by the ACP, Inc. 24/7 ComServ Support Center, 866-426-2621.



# DairyQueen Commercial Boosting Oven Model DQ22HSI2 | Heavy Volume

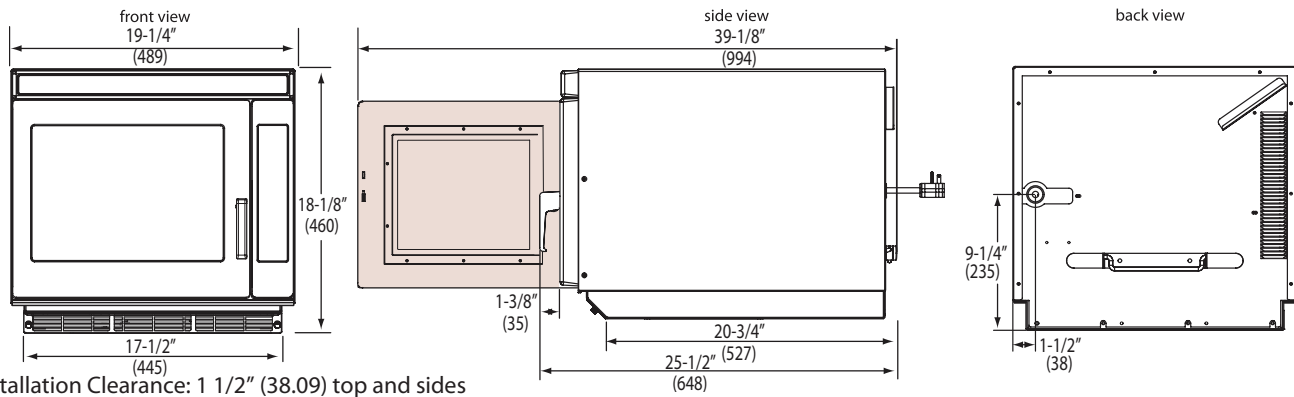

Installation Clearance: 1 1/2" (38.09) top and sides

Specifications			
Model	DQ22HSI2	UPC Code 719881159324	
Configuration	Countertop		
Control System	Touch		
Programmable Control Pads	10		
Settings Programmable	400		
Max. Cooking Time	60:00		
Power Levels	11		
Defrost	Yes, power level 2 or 20%		
Time Entry Option	Yes		
Microwave Distribution	Double rotating antenna		
Magnetrons	2		
Display	LED-backlit LCD		
Stackable	Yes		
Stage Cooking	Yes, 4		
Door Opening	Lift and pull handle		
Signal	Adjustable, end of cycle		
Air Filter	Yes, removable, with clean filter reminder		
Automatic Voltage Sensor	Yes		
Multiple Portion Setting	Yes, up to 8 items		
Exterior Dimensions	H 18 1/8" (460)	W 19 1/4" (489)	D** 25 1/2" (648)
Cavity Dimensions	H 8 1/2" (216)	W 13" (330)	D 15" (381)
Door Depth	39 1/8" (994 mm), 90°+ door open		
Usable Cavity Space	1.0 cubic ft. (28 liter)		
Exterior Finish	Stainless steel		
Interior Finish	Stainless steel with sealed-in ceramic shelf		
Power Consumption	3300 W, 15.9 A		
Power Output*	2200 W* Microwave		
Power Source	208 - 240V, 60 Hz, 20 A single phase		
Plug Configuration / Cord	NEMA 6-20	5 ft. (1.5 m)	
Frequency	2450 MHz		
Product Weight	94 lbs. (43 kg.)		
Ship weight (approx.)	101 lbs. (46 kg.)		
Shipping Carton Size	L 28 1/4" (718)	W 21 3/4" (553)	H 21 1/2" (546)

## Warranty

Full 3 year warranty:  
3 years – parts, labor, and travel are covered.

## Service

All products are backed by the ACP, Inc. 24/7 ComServ Support Center.



866-426-2621

Measurements in ( ) are millimeters

\* IEC 705 Tested

\*\* Includes handle

