

MENUMASTER[®] Commercial

McDonald's Heavy Volume Q-ing Oven



Heavy Volume

MenuMaster Model MC23MPW2 / MC23MPTW2

Power Output

- 2000 watts of power.
- 11 power levels for consistent, delicious results.
- Unique method of energy distribution provides superior even heating throughout the cavity.

Easy to Use

- Menu codes and boost heat times are preprogrammed for simplified and consistent cooking results.
- Four stage cooking option for one-touch operation. Reduces prep time, labor and food waste while providing consistent results.
- Controls are user friendly and require minimal training.
- Control automatically prompts user to enter quantity.
- Automatic Voltage Sensor accommodates 208 and 240 volts allowing easy installation.
- Ample 1.0 cubic ft. (28 liter) capacity provides easy, safe oven accessibility.
- Interior ceramic shelf is sealed and recessed to reduce edge impact and keep spills contained.
- Stackable to save valuable counter space.

Easy to Maintain

- Stainless steel exterior and interior for easy cleaning and a professional look.
- Constructed to withstand the McDonald's environment.
- Robust interlock switch assemblies provide maximum durability and reliability.
- Removable, cleanable air filter and clean filter reminder protects oven components.
- Removable splatter shield cleans easily.
- Full 2 year warranty.
- Backed by the ACP, Inc. 24/7 ComServ Support Center, 866-426-2621.



866-426-2621

Program Times for McDonald's

Product	Q-ing Code	Quantity/Time (minutes : seconds)			
		1	2	3	4
McGriddles	11	0:08	0:13	0:18	-
Buttermilk Biscuits	22	See timing chart below			
Hotcakes	33	0:21	0:41	-	-
Burrito	55	0:17	0:30	0:45	0:60
Cinnamon Melts (new)	77	0:14	0:25	-	-
(Original Rect. roll)	77	0:06	0:10	0:15	0:20
Fajita	12	0:13	0:23	0:35	0:50

Oven Type/Biscuit Size	Q-ing Code	1 Full Tray	(2) 1/2 Trays	(4) 1/4 Trays
Blodgett, Hobart, Wells				
Buttermilk Biscuits	22	2:00	1:10	0:36
Large Buttermilk Biscuits	22	2:00	1:15	0:45
Garland Multi-Purpose				
Buttermilk Biscuits	22	2:00	1:15	0:45
Large Buttermilk Biscuits	22	2:00	1:15	0:45
Blodgett (SPODS)				
Buttermilk Biscuits	22	2:00	1:15	0:47
Large Buttermilk Biscuits	22	2:00	1:08	0:45

Note: All power levers should be set on HIGH.



McDonald's Q-ing Ovens Models MC23MPW2 / MC23MPTW2 | Heavy Volume

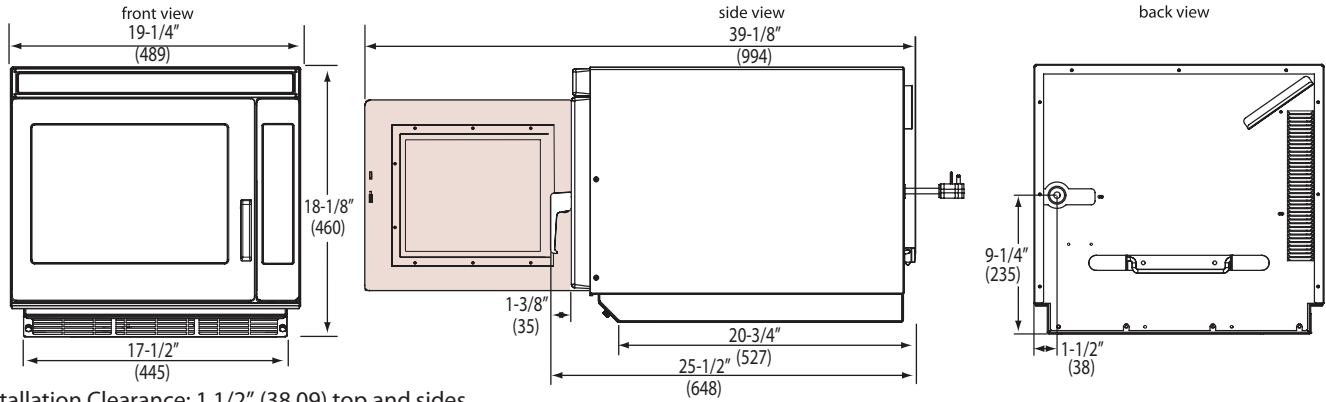

Installation Clearance: 1 1/2" (38.09) top and sides

Specifications			
Model	MC23MPW2	UPC Code 719881159478	
	MC23MPTW2	UPC Code 719881159461	
Configuration	Countertop		
Control System	Touch		
Programmable Control Pads	10		
Settings Programmable	400		
Max. Cooking Time	60:00		
Power Levels	11		
Defrost	Yes, power level 2 or 20%		
Time Entry Option	Yes		
Microwave Distribution	Three rotating antenna		
Magnetrons	3		
Display	LED-backlit LCD		
Stage Cooking	Yes, 4		
Interior Light	No		
Door Opening	Lift and pull handle		
Signal	Adjustable, end of cycle		
Air Filter	Yes, removable, with clean filter reminder		
Automatic Voltage Sensor	Yes		
Multiple Setting	Yes		
Exterior Dimensions	H 18 1/8" (460)	W 19 1/4" (489)	D** 25 1/2" (648)
Cavity Dimensions	H 8 1/2" (216)	W 13" (330)	D 15" (381)
Door Depth	39 1/8" (994 mm), 90°+ door open		
Usable Cavity Space	1.0 cubic ft. (28 liter)		
Exterior Finish	Stainless steel		
Interior Finish	Stainless steel with sealed-in ceramic shelf		
Power Consumption	3200 W, 15.4 A		
Power Output*	2000 W* Microwave		
Power Source	208 - 240V, 60 Hz, 20 A single phase		
MC23MPW2 Plug Info	Pin and Sleeve	5' (1.5 m) cord	☹
MC23MPTW2 Plug Info	NEMA L6-20P	5' (1.5 m) cord	☺
	twist lock		
Frequency	2450 MHz		
Product Weight	115 lbs. (52 kg.)		
Ship weight (approx.)	123 lbs. (56 kg.)		
Shipping Carton Size	L 28 1/4" (718)	W 21 3/4" (553)	H 21 1/2" (546)

Warranty

Full 2 year warranty:

Years 1 - 2 - parts, labor, and travel are covered.
Year 3 - magnetron tube (part only) is covered.

Service

All products are backed by the ACP, Inc. 24/7 ComServ Support Center.



866-426-2621

Made exclusively for McDonald's, this proprietary oven is versatile, durable and easy to operate.

Measurements in () are millimeters

* IEC 705 Tested

** Includes handle

