

# MENUMASTER<sup>®</sup>

## Commercial

### Wendy's Heavy Duty Oven



Designed exclusively for Wendy's, this proprietary oven is versatile, durable and easy to operate.

All ACP, Inc. commercial ovens are backed by our Culinary Center. Call us with any question regarding food preparation, menu development and cooking times 866-426-2621.



866-426-2621

## Heavy Volume

Menumaster Commercial Microwave Model WDYRC22

#### Power Output

- 2000 watts of power.
- 11 power levels for consistent, delicious results for frozen, refrigerated and fresh foods.
- Unique method of energy distribution provides superior even heating throughout the cavity.

#### Easy to Use

- Preprogrammed pads simplify cooking and ensure consistent results.
- Four stage cooking option with one-touch operation. Reduces prep time, labor and food waste while providing consistent results.
- Controls are user friendly and require minimal training.
- Multiple quantity pad calculates the proper cook times for multiple items.
- Automatic Voltage Sensor accommodates 208 and 240 volts allowing easy installation.
- See-through door and lighted interior for monitoring without opening the door.
- Ample 1.0 cubic ft. (28 liter) capacity accommodates up to 24 buns.
- Interior ceramic shelf is sealed and recessed to reduce plate-to-shelf edge impact and keep spills contained.
- Stackable to save valuable counter space.

#### Easy to Maintain

- Stainless steel exterior and interior for easy cleaning and a professional look.
- Constructed to withstand the foodservice environment.
- Removable, cleanable air filter and clean filter reminder protects oven components.
- Removable splatter shield cleans easily.
- Full 3 year warranty.
- Backed by the ACP, Inc. 24/7 ComServ Support Center, 866-426-2621.



# Wendy's Commercial Oven Model WDYRC22 | Heavy Volume

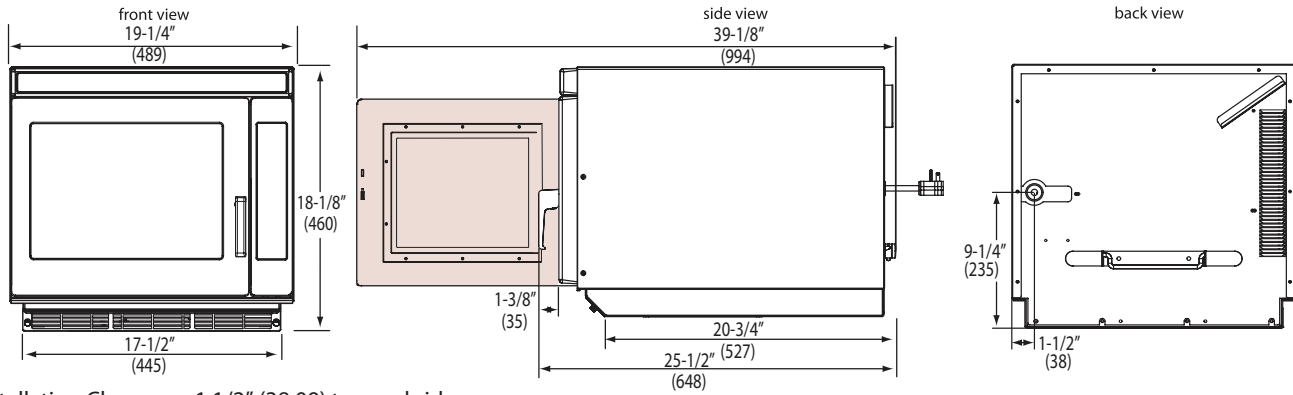

Installation Clearance: 1 1/2" (38.09) top and sides

Specifications			
Model	WDYRC22	UPC Code 719881159713	
Configuration	Countertop		
Control System	Touch		
Programmable Control Pads	10		
Settings Programmable	100		
Max. Cooking Time	60:00		
Power Levels	11		
Defrost	Yes, power level 2 or 20%		
Time Entry Option	Yes		
Microwave Distribution	Double rotating antenna		
Magnetrons	2		
Display	LED-backlit LCD		
Stackable	Yes		
Stage Cooking	Yes, 4		
Interior Light	Yes		
Door Opening	Lift and pull handle		
Signal	Adjustable, end of cycle		
Air Filter	Yes, removable, with clean filter reminder		
Automatic Voltage Sensor	Yes		
Multiple Portion Setting	Yes, up to 8 items		
Exterior Dimensions	H 18 1/8" (460)	W 19 1/4" (489)	D** 25 1/2" (648)
Cavity Dimensions	H 8 1/2" (216)	W 13" (330)	D 15" (381)
Door Depth	39 1/8" (994 mm), 90°+ door open		
Usable Cavity Space	1.0 cubic ft. (28 liter)		
Exterior Finish	Stainless steel		
Interior Finish	Stainless steel with sealed-in ceramic shelf		
Power Consumption	3200 W, 15.4 A		
Power Output*	2000 W* Microwave		
Power Source	208 - 240V, 60 Hz, 20 A single phase		
Plug Configuration / Cord	NEMA 6-20	5 ft. (1.5 m)	
Frequency	2450 MHz		
Product Weight	94 lbs. (43 kg.)		
Ship weight (approx.)	101 lbs. (46 kg.)		
Shipping Carton Size	L 28 1/4" (718)	W 21 3/4" (553)	H 21 1/2" (546)

## Warranty

Full 3 year warranty:  
3 years – parts, labor, and travel are covered.

## Service

All products are backed by the ACP, Inc. 24/7 ComServ Support Center.



Measurements in ( ) are millimeters

\* IEC 705 Tested

\*\* Includes handle

