

Commercial Microwave—Technical Information

208/230 V, 60 Hz Models

HDC18	P1323003M	CRC18T2OG	P1323006M
HDC18SD	P1323004M	CRC21T2RL	P1323007M
HDC21	P1323005M		

- Due to possibility of personal injury or property damage, always contact an authorized technician for servicing or repair of this unit.
- Refer to Service Manual RS2240002 for installation, operating, testing, troubleshooting, and disassembly instruction.
- Refer to Parts Manual RP2230004 for part number information.



CAUTION

All safety information must be followed as provided in Service Manual RS2240002.



WARNING

To avoid the risk of electrical shock, personal injury, or death, disconnect power to oven and discharge capacitor before servicing, unless testing requires power.

Models	HDC18 HDC18SD CRC18T2OG	HDC21 CRC21T2RL
Power Source		
Voltage AC	230/208 VAC	230/208 VAC
Amperage (Single Unit)	20 A	20 A
Frequency	60 Hz	60 Hz
Single Phase, 3 wire grounded	X	X
Receptacle	6-20R	6-20R
Plug	6-20P	6-20P
Power Output		
Nominal microwave energy (IEC705)	1800 Watts	2100 Watts
Operating Frequency	2450 MHz	2450 MHz
Power Consumption		
Cook Condition Microwave	2850 Watts	3450 Watts
Dimensions		
Cabinet		
Width	16 5/8"	16 5/8"
Height	13 3/16"	13 3/16"
Depth	21 9/16"	21 9/16"
Oven Interior		
Width	13"	13"
Height	6 7/8"	6 7/8"
Depth	12"	12"
Weight		
Crated	74 lbs.	74 lbs.
Uncrated	68 lbs.	68 lbs.

Component Testing Procedures

⚠ WARNING

To avoid risk of electrical shock, personal injury, or death, disconnect power to oven and discharge capacitor before servicing, unless testing requires power.

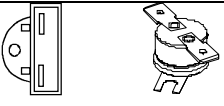
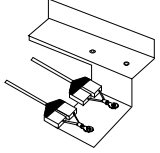
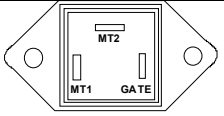
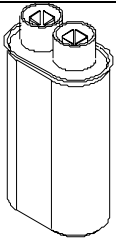
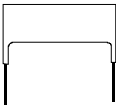
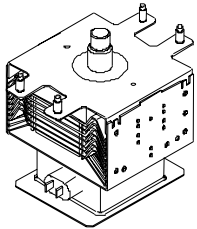
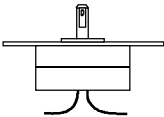
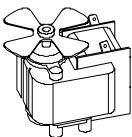
Illustration	Component	Test	Results
	Thermal Cutout B5795302..... B5684121.....	Disconnect all wires from TCO. Measure resistance across terminals. Cavity Thermal Fuse..... Magnetron TCO.....	Open at 219° F (104° C). Open at 280° F (138° C) and closed at 180° F (82° C).
	Diode Assembly	Discharge Capacitors Remove diode lead from capacitor and connect ohmmeter. Reverse leads for second test.	Infinite resistance should be measured in one direction and 50KΩ or more in the opposite direction. NOTE: Analog meter must contain a battery of 6 volts minimum.
	Triac	Disconnect wires to triac. Measure resistance from: MT1 to MT2 MT1 to Gate..... MT2 to Gate..... All terminals to ground.....	Caution - Do not operate oven with wire to terminal MT2 removed. Infinite. Approximately 40 Ω or more. Infinite. Infinite.
	Capacitor CRC18T2OG, HDC18, HDC18SD 10366919 HDC21, CRC21T2RL 10366917	Discharge Capacitors Remove wires from capacitor terminals and connect ohmmeter, set on highest resistance scale to terminals. Also check between each terminal and capacitor case.	Between Terminals: Meter should momentarily deflect towards zero then return to over 5 MΩ. If no deflection occurs, or if continuous deflection occurs, replace capacitor. Terminal to Case: Infinite resistance.
	Snubber Assembly	Disconnect wires to snubber. Measure resistance across terminals.....	Infinite.
	Magnetron CRC18T2OG, HDC18, HDC18SD D7831007 HDC21, CRC21T2RL 10489404	Discharge Capacitors Remove wires from magnetron and connect ohmmeter to terminals. Also check between each terminal and ground.	Between Terminals: Less than 1 Ω. Each terminal to ground measures Infinite resistance. NOTE: This test is not conclusive. If oven does not heat and all other components test good replace the magnetron and retest.
R0150197 top R9900668 bottom 	Stirrer motor	Remove all wires from terminals. Measure resistance from: Terminal to terminal.....	Approximately 12 KΩ.
	Blower Motor	Remove all wires from motor. Measure resistance across coil.....	Approximately 30 Ω.

Component Testing Procedures

⚠ WARNING

To avoid risk of electrical shock, personal injury, or death, disconnect power to oven and discharge capacitor before servicing, unless testing requires power.

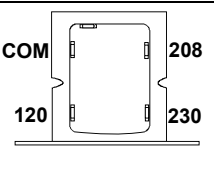
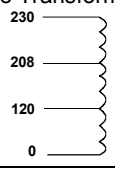
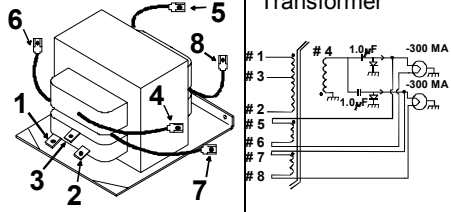
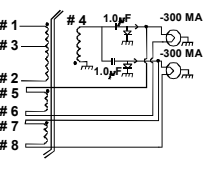
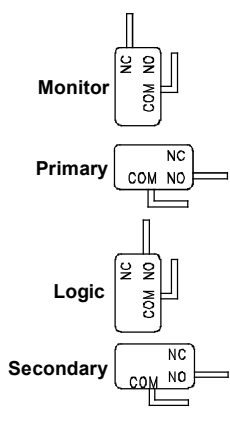
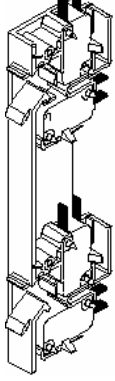
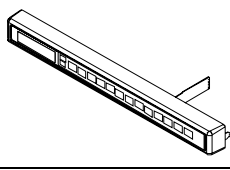
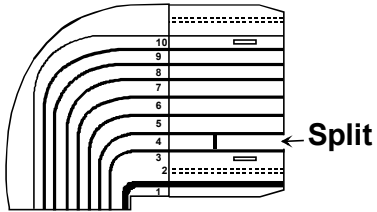
Illustration	Component	Test	Results		
	Auto Transformer 	Discharge Capacitors Remove all wires from terminals. Measure resistance from: 230 to 0 208 to 0 120 to 0	42.4 Ω. 38.6 Ω. 21.5 Ω.		
 <p>Terminal 1 - 230 V Terminal 2 - Common Terminal 3 - 208 V</p>	Transformer 	Discharge Capacitors Remove all wires from terminals. Measure resistance from: Terminal 1 to 2 Terminal 1 to 3 Terminal 5 to 6 Terminal 7 to 8 Terminal 4 to Ground screw on transformer... Terminal 4 to any other terminal.....	1.0 Ω. Less than 1 Ω. Less than 1 Ω. Less than 1 Ω. 30 Ω. Infinite resistance. If not, replace transformer.		
	Interlock switch assembly 	Disconnect wires to switch. With door open measure resistance from: Terminal C to NC Monitor Terminal C to NO Primary Terminal C to NO Logic Terminal C to NO Secondary With door closed measure resistance from: Terminal C to NC Monitor Terminal C to NO Primary Terminal C to NO Logic Terminal C to NO Secondary	Continuity. Infinite. Infinite. Infinite. Infinite. Continuity. Continuity. Continuity.		
HDC21, HDC18SD, HDC18 R9900111 CRC18T2OG, CRC21T2RL R9900580 	Touch Panel Assembly	Continuity is indicated as 100 Ω and below. Pin 1: Ground. 	Pad 1 2 3 4 5 6 7 8 9 0 Start Stop/Reset Power Level X 2 Time Entry	Trace 8 & 10 7 & 10 6 & 10 5 & 10 4 & 10 3 & 10 8 & 9 7 & 9 6 & 9 5 & 9 4 & 9 4 & 8 5 & 8 6 & 8 7 & 8	Measurement Continuity Continuity Continuity Continuity Continuity Continuity Continuity Continuity Continuity Continuity Continuity Continuity Continuity Continuity
Wire Harness		Test continuity of wires.....	Continuity.		

Component Testing Procedures

⚠ WARNING

To avoid risk of electrical shock, personal injury, or death, disconnect power to oven and discharge capacitor before servicing, unless testing requires power.

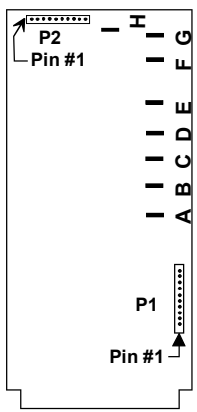
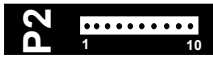
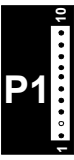
Illustration	Component	Test	Results
CRC18T20G 12495201Q CRC21T2RL 12495202Q HDC18, HDC18SD, HDC21 12470107 	Controller board   P1 connector used for touch panel ribbon	All Models Line voltage to control board P2 connector Pin 1—Pin 3..... Output drive voltage to triac Triac terminals..... Gate—T1..... 208 VAC line voltage Fan relay (controls blower motor, antenna motor(s), and oven light) Control board..... Terminals C—D..... Line voltage sensing relay (automatically switches for 208 or 230 VAC operation) Control board..... Terminals F—G..... 230 VAC line voltage Fan relay (controls blower motor, antenna motor(s), and oven light) Control board..... Terminals C—E..... Line voltage sensing relay (automatically switches for 208 or 230 VAC operation) Control board..... Terminals F—H.....	Line voltage (All Condition) 0 VAC (Idle and Standby) 0.9 VAC (Cook) Line voltage (Idle) 0 VAC (Standby and Cook) Line voltage (Idle) 0 volts (Standby and Cook) Line voltage (Idle) 0 VAC (Standby and Cook) Line voltage (Idle) 0 volts (Standby and Cook)

Error Code Table

Error Code	Corrective Action
F1	Replace HV/LV Board
F2	Replace HV/LV Board
F3	Replace HV/LV Board
F4	Replace Touch Panel
F5	Replace HV/LV Board

Conditions

- Initial Power Up Condition:** Apply power to oven with door closed.
- Idle Condition:** Oven plugged in, display blank (no other components operating).
- Standby Condition:** Open oven door, light and motors operate.
- Cook Condition:** Food load in oven, cook cycle initiated.

Component Testing Procedures



WARNING

To avoid risk of electrical shock, personal injury, or death, disconnect power to oven and discharge capacitor before servicing, unless testing requires power.

Power Test (Traditional Test Method)

Test equipment required is Amana power test kit R0157397 (Fahrenheit), or Menumaster power test kit M95D5 (Celsius).

1. Fill the plastic container to the 1000 ml. line with cool tap water.
2. Using the thermometer; stir the water, measure, and record the water temperature.

Initial water temperature should be approximately 60° F (16° C).

3. Place container on the center of the oven shelf and heat the water for **33 seconds for ovens with more than 1550 watts or 63 seconds for ovens with less than 1550 watts.**

NOTE: Use a watch second hand, not the oven timer.

4. Stir the water, measure and record the temperature of the water after heating time is complete.
5. Subtract the starting water temperature (Step 2), from the ending water temperature (Step 4) to obtain the temperature rise (ΔT).
6. See the Traditional Power Test Temperature Chart below.

NOTES:

- The IEC-705 test method requires precision measurements and equipment. It is not practical to perform the IEC test in the field. To convert the traditional power test results to the approximate IEC-705 rating, take the traditional power test results and add 100 watts per magnetron for the unit being tested.

Example: 1627 watts output using the traditional power test for model HDC21RB
+ 200 watts (2 magnetrons X 100 watts)
 1827 Approximate IEC-705 results

- Always perform power test three times for accuracy, changing the water after each test is performed.
- Variation or errors in the test procedure will cause a variance in the temperature rise. Additional power tests should be made if temperature rise appears marginal.
- Low line voltage will cause lower temperature rise.

Traditional Power Test Temperature Chart

THIRTY THREE (33) SECONDS run time chart for units more than 1550 Watts cooking power

ΔT (°F)	Cooking Power Output	ΔT (°F)	Cooking Power Output	ΔT (°C)	Cooking Power Output	ΔT (°C)	Cooking Power Output
17	1319	24	1860	11	1540	14	1960
18	1395	25	1937	11.5	1610	14.5	2030
19	1472	26	2015	12	1680	15	2100
20	1550	27	2092	12.5	1750	15.5	2170
21	1627	28	2170	13	1820	16	2240
22	1705	29	2247	13.5	1890		
23	1782						

SIXTY-THREE (63) SECONDS run time chart for units less than 1550 Watts cooking power

ΔT (°F)	Cooking Power Output	ΔT (°F)	Cooking Power Output	ΔT (°C)	Cooking Power Output	ΔT (°C)	Cooking Power Output
18	697	27	1046	10	700	16	1120
19	736	28	1085	11	770	17	1190
20	775	29	1124	12	840	18	1260
21	814	30	1162	13	910	19	1330
22	852	31	1201	14	980	20	1400
23	891	32	1240	15	1050		
24	930	33	1279				
25	969	34	1317				
26	1007	35	1359				

Wiring and Schematic Diagrams

WARNING

To avoid risk of electrical shock, personal injury, or death, disconnect power to oven and discharge capacitor before servicing, unless testing requires power.

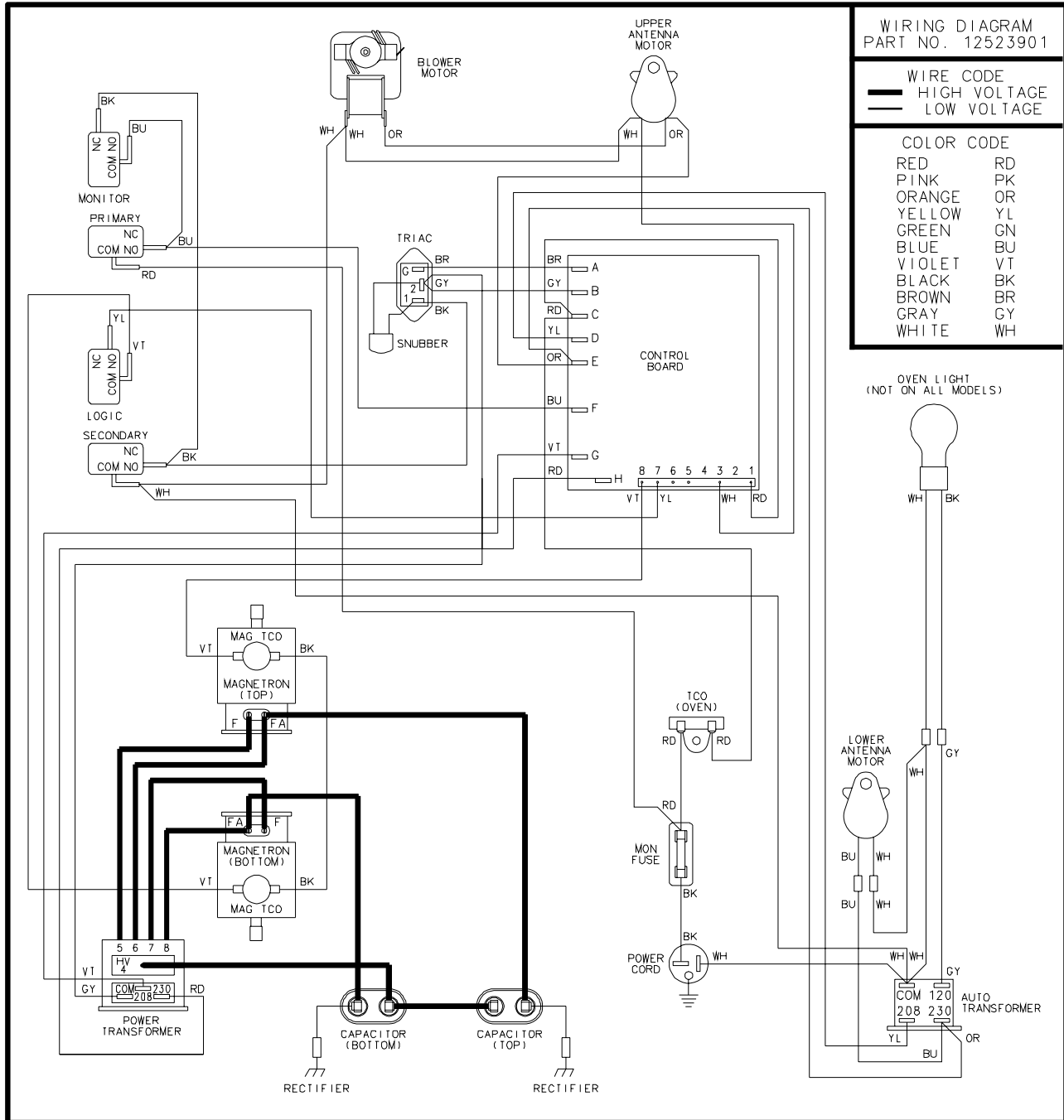

Wiring and Schematic Diagram



WARNING

To avoid risk of electrical shock, personal injury, or death, disconnect power to oven and discharge capacitor before servicing, unless testing requires power.

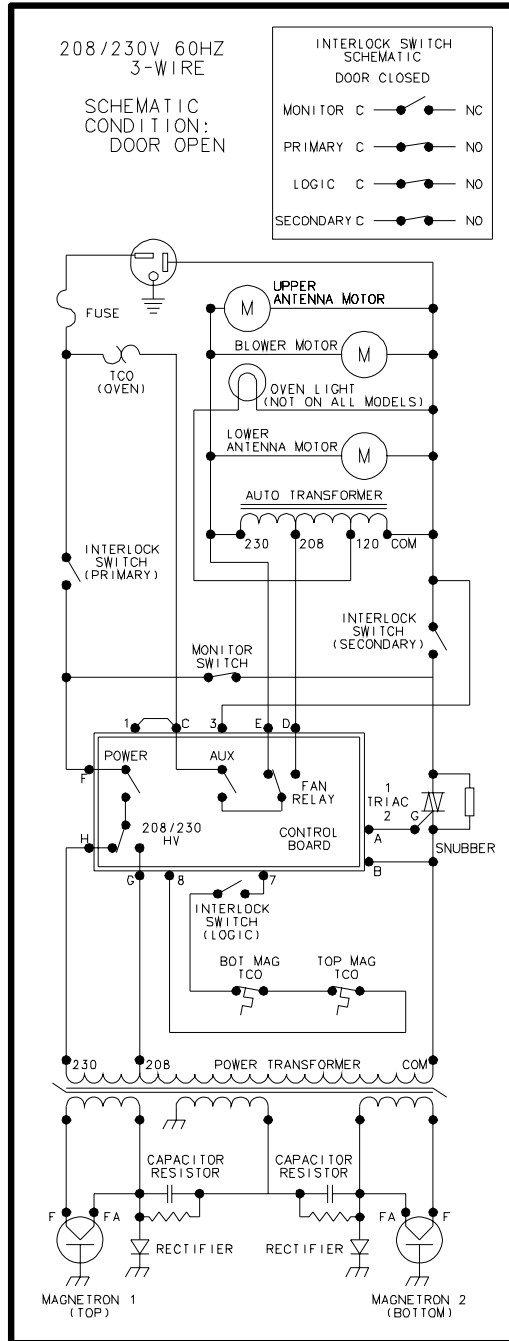

12523901



DANGER

HIGH VOLTAGE