

# Commercial Microwave-Technical Information

208 / 230 VAC, 60 Hz model

<b>OC24</b>	<b>P2000301M</b>	<b>OC24BK</b>	<b>P2000302M</b>
<b>OC24BKB</b>	<b>P2000316M</b>	<b>MOC24</b>	<b>P2000305M</b>
<b>MOC24B</b>	<b>P2000315M</b>	<b>AOC24</b>	<b>P2000306M</b>
<b>MOC24RB</b>	<b>P2000314M</b>		

- Due to possibility of personal injury or property damage, always contact an authorized technician for servicing or repair of this unit.
- Refer to Service Manual for installation, operating, testing, troubleshooting, and disassembly instruction.

## CAUTION

All safety information must be followed as provided in Service Manual.

## WARNING

To avoid the risk of electrical shock, personal injury or death; disconnect power to oven and discharge capacitor before servicing, unless testing requires power.

Models	OC24 / OC24BK* MOC24* / AOC24	
<b>Power Source</b>		
Voltage AC	208-230 VAC	
Amperage (Single Unit)	20 A	
Frequency	60 Hz	
Single Phase, 3 wire grounded	X	
Receptacle	NEMA 6-20R	
Plug	NEMA 6-20P	
<b>Power Output – Microwave</b>		
Nominal microwave energy (IEC705)	2400 Watts	
Minimum temperature rise (ΔT)	24°F / 13°C	
Operating Frequency	2450 MHz	
<b>Power Consumption</b>		
Microwave	3700 Watts	
<b>Dimensions</b>		
<b>Cabinet (in cm)</b>		
Width	13 5/8"	34.6 cm
Height	17 3/4"	45.1 cm
Depth (Includes Handle)	18 5/8"	47.3 cm
<b>Oven Interior (in cm)</b>		
Width	5 3/8"	13.6 cm
Height	11 3/4"	29.8 cm
Depth	10"	25.4 cm
<b>Weight</b>		
Uncrated	70 lbs.	32.0 kg
<b>Features</b>		
Timer (Max Time)	10:00 /5:00, Preset	
Cavity Volume	.312 cu. Ft. (.008m3)	

# Troubleshooting Chart



## WARNING

To avoid risk of electrical shock, personal injury or death; disconnect power to oven and discharge capacitor before servicing, unless testing requires power.

### Initial Power-Up (Door Open)

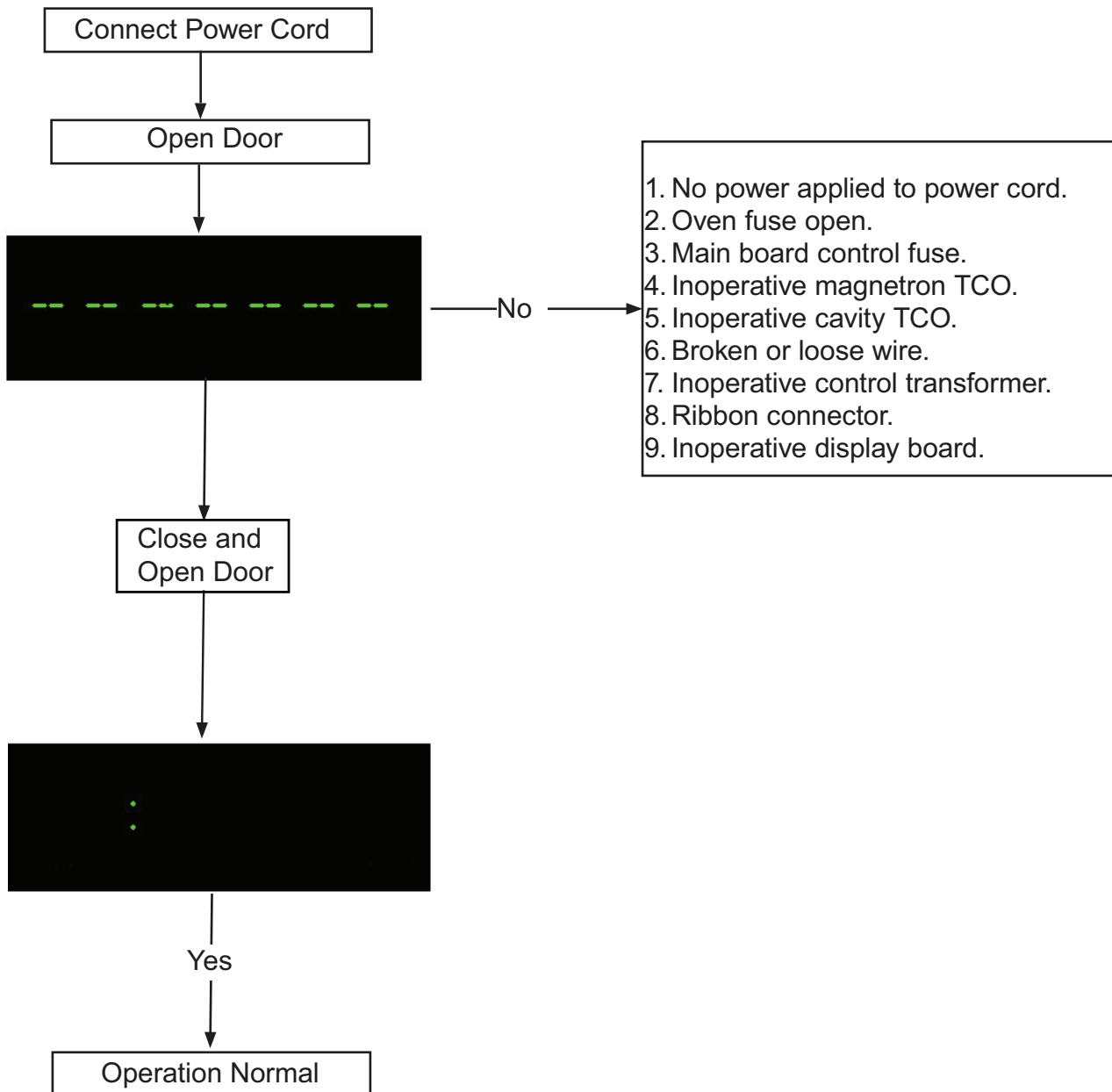

# Troubleshooting Chart



## WARNING

To avoid risk of electrical shock, personal injury or death; disconnect power to oven and discharge capacitor before servicing, unless testing requires power.

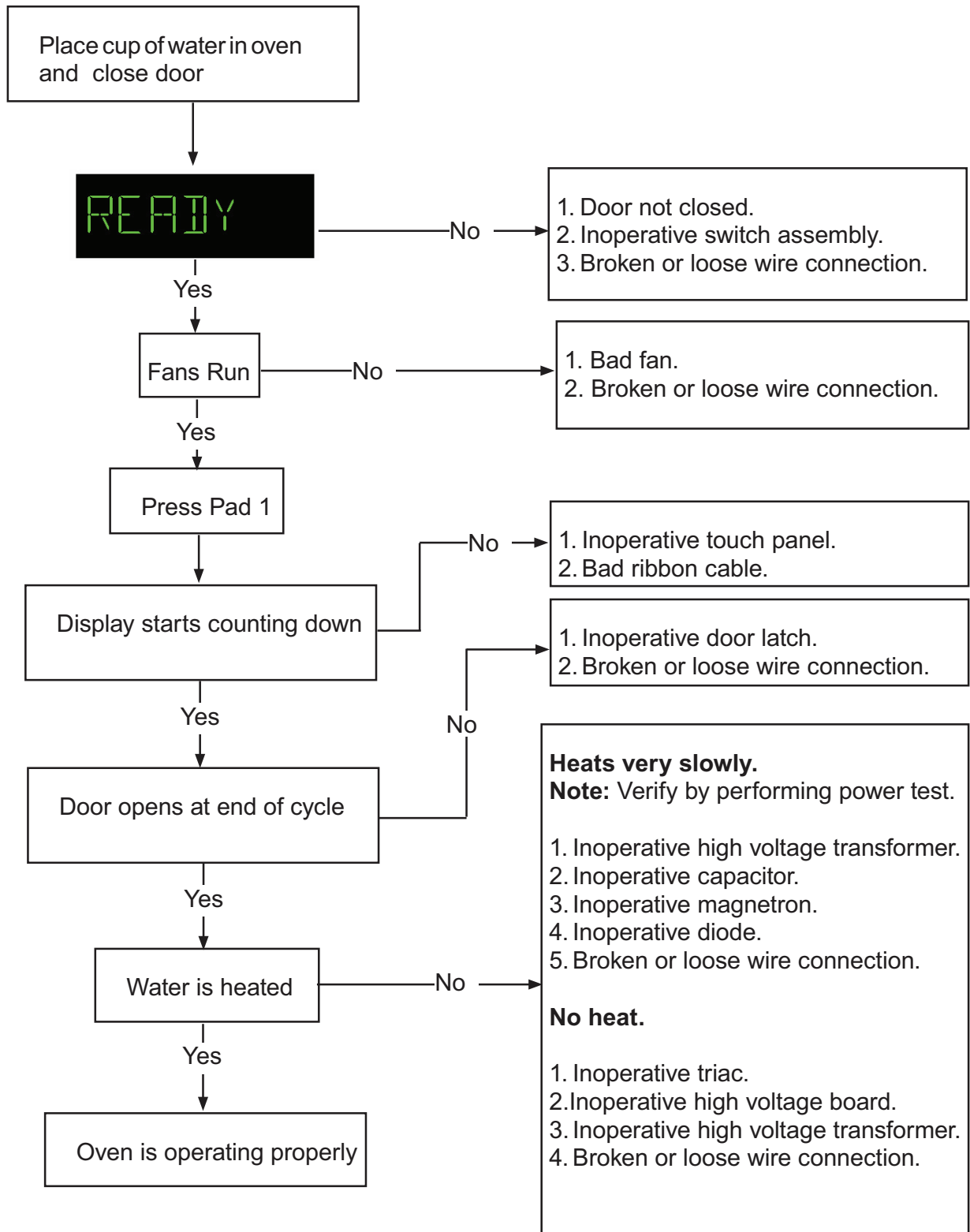

### Cook Condition



# Troubleshooting Chart

## **WARNING**

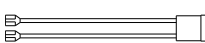
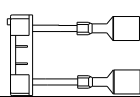
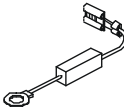
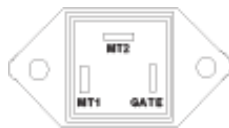
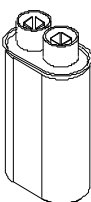
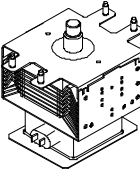
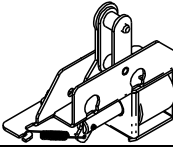
To avoid risk of electrical shock, personal injury or death; disconnect power to oven and discharge capacitor before servicing, unless testing requires power.

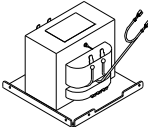
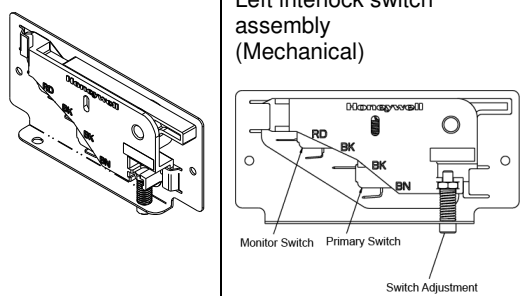
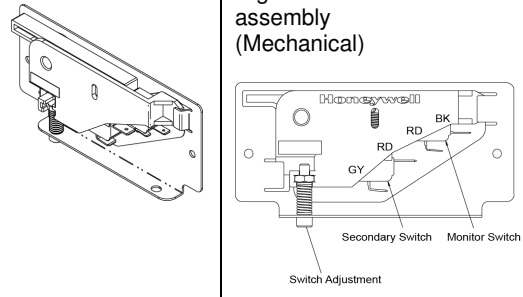
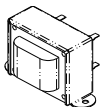

Illustration	Component	Testing	Results
	Magnetron TCO	Disconnect all wires from TCO. Measure resistance across terminals. Magnetron TCO .....	Closed at 257°F (125°C) and Opens at 300°F (149°C)
	Latch TCO	Disconnect all wires from TCO. Measure resistance across terminals. Latch TCO.....	Opens at 230°F (110°C) and Closes at 150°F (66°C)
	Cavity TCO	Disconnect all wires from TCO. Measure resistance across terminals. Cavity TCO .....	Opens at 219°F (104°C)
	Diode	<b>Discharge Capacitor</b>  Remove diode lead from capacitor and connect ohmmeter.  Reverse leads for second test.	Infinite resistance should be measured in one direction and 50KΩ or less in the opposite direction.  <b>NOTE:</b> Ohmmeter must contain a battery of 6 volts minimum.
	Triac	<b>Resistance Check</b> Disconnect wires to triac Measure resistance from: MT1 to MT2 MT1 to Gate MT2 to Gate All terminals to ground	<b>Caution – Do not operate oven with wire to terminal MT2 removed.</b>  Infinite Approximately 60Ω Infinite Infinite
		<b>Voltage Check</b> Measure voltage from: MT1 to Gate MT1 to MT2	0.8 VAC when energized. 0 volts when gate energized or closed. Line volts when gate not energized or open.
	Capacitor	<b>Discharge Capacitor</b> Remove wires from capacitor terminals and connect ohmmeter, set on highest resistance scale to terminals.  Also check between each terminal and capacitor case.	Between Terminals: Meter should momentarily deflect towards zero then return to over 5 MΩ. If no deflection occurs, or if continuous deflection occurs, replace capacitor.  Terminal to Case: Infinite resistance
	Magnetron	<b>Discharge Capacitor</b>  Remove wires from magnetron and connect ohmmeter to terminals. Also check between each terminal and ground.	Between Terminals: Less than 1 Ω  Each terminal to ground measures Infinite resistance. <b>Note:</b> This test is not conclusive. If oven does not heat and all other components test good replace the magnetron and retest.
	Solenoid (Left, Right)	Disconnect connector from solenoid  Measure resistance across coil .....	Approximately 6-11 Ω
	Stirrer motor	Remove all wires from motor.  Measure resistance across terminals ....	Approximately 12K Ω

# Troubleshooting Chart



## WARNING

To avoid risk of electrical shock, personal injury or death; disconnect power to oven and discharge capacitor before servicing, unless testing requires power.

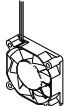
Illustration	Component	Testing	Results
	Transformer, HV	<b>Discharge Capacitor</b> Remove all wires from terminals. Measure resistance from: 230 to COM..... 208 to COM..... 230 to Ground..... 208 to Ground..... Terminal 5 to 6..... Terminal 7 to 8..... Terminal 4 to Ground.....	Less than 1 Ω Less than 1 Ω Infinite Infinite Less than 1 Ω Less than 1 Ω Approximately 27 Ω
	Main board	See Main Board page 6	
	Left interlock switch assembly (Mechanical)	Disconnect wires to switch.  With door open measure resistance from: Monitor – Terminals Rd- BK..... Primary – Terminals Bk - Brn.....  With door closed measure resistance from: Monitor – Terminals RD - BK..... Primary – Terminals BK - BN.....  <b>After verifying or replacing the assembly, re-connect wires to switch and check operation of monitor circuit before operating the oven.</b>	Indicates continuity Infinite Ω  Infinite Ω Indicates continuity
	Right interlock switch assembly (Mechanical)	Disconnect wires to switch.  With door open measure resistance from: Monitor – Terminals RD- BK..... Secondary – Terminals GY -RD .....  With door closed measure resistance from: Monitor – Terminals RD - BK..... Secondary – Terminals GY - RD .....  <b>After verifying or replacing the assembly, re-connect wires to switch and check operation of monitor circuit before operating the oven.</b>	Indicates continuity Infinite Ω  Infinite Ω Indicates continuity
	Transformer, control	(1) BU to (5) BR ..... (6) YL to (10) WH.....	Approximately 40 Ω or Line Voltage Approximately 1 Ω or 28 VAC
	Fan, cooling	Disconnect connector from fan.  Measure voltage at incoming leads .....	Approximately 24VDC
	Fan, exhaust	Disconnect connector from fan.  Measure voltage at incoming leads .....	Approximately 24VDC

# Troubleshooting Chart



## WARNING

To avoid risk of electrical shock, personal injury or death; disconnect power to oven and discharge capacitor before servicing, unless testing requires power.

### Main. Board

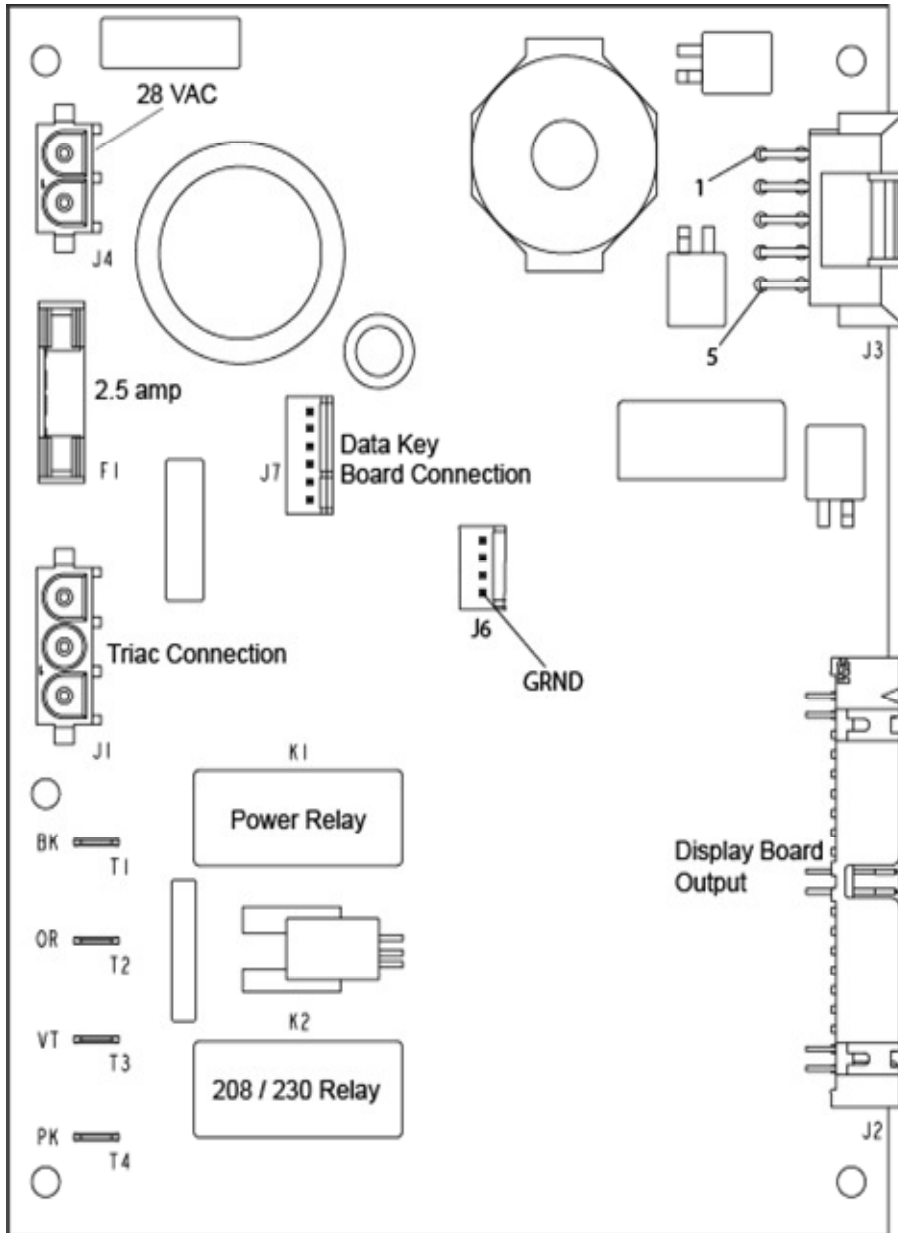

Function	Test Set-Up	Meter Setting	Probe Placement	Results
Input to main board Left, Right Switch Assembly	Main Board (Door Closed)	Volts	Main Board T-1 (Black wire) Triac (Red wire)	Line voltage
J4 Input from Control Transformer	Main Board	Volts	J4-1 & J4-2	28 VAC

# Troubleshooting Chart



## WARNING

To avoid risk of electrical shock, personal injury or death; disconnect power to oven and discharge capacitor before servicing, unless testing requires power.

Function	Test Set-Up	Meter Setting	Probe Placement	Results
2.5 amp fuse <b>Note:</b> If Fuse is blown unit is non operational Fuse is field replaceable.	Remove fuse from holder	Ohms	Measure resistance across fuse	Continuity
208/230 Volt Relay 230 Volt Output	T4 to Blue wire at J1 Triac connection	Volts	T4 to Blue wire at Triac Connection	230 volts when 230 volts line voltage present
208/230 Volt Relay 208 Volt Output	T3 to Blue wire at J1 Triac connection	Volts	T3 to Blue wire at Triac Connection	208 volts when 208 volts line voltage present
J1 Triac Output Connection	Orange wire to Red wire	Volts	Orange wire at Triac Connection. Red wire at Triac Connection	0.8 VAC when Triac energized
Power Relay (K1)	T2 to Blue wire at J1 Triac connection	Volts	T2 to Blue wire at Triac Connection	208 volts when 208 volts line voltage present
	T2 to Blue wire at J1 Triac Connection	Volts	T2 to Blue wire at Triac Connection	230 volts when 230 volts line voltage present

Illustration	Component	Test	Pad	Trace	Results
	Keypad	Removal of touch panel is required to perform test. Continuity is indicated as 100 Ω and below.  	1	8 & 10	Continuity
			2	7 & 10	Continuity
			3	6 & 10	Continuity
			4	5 & 10	Continuity
			5	4 & 10	Continuity
			6	3 & 10	Continuity
			7	8 & 9	Continuity
			8	7 & 9	Continuity
			9	6 & 9	Continuity
			0	5 & 9	Continuity
			Start	4 & 9	Continuity
Stop	4 & 8	Continuity			
Power Level	5 & 8	Continuity			
Time Entry	7 & 8	Continuity			

# Power Test (AOC24, MOC24\*, OC24, OC24BK\* Models)



## WARNING

To avoid risk of electrical shock, personal injury or death; disconnect power to oven and discharge capacitor before servicing, unless testing requires power.

All Amana and Menumaster microwave oven power outputs are rated using the IEC705 standards. Using the IEC705 test method requires precision measurements and equipment that is not practical to be performed in the field. Using the test shown below will indicate if the oven performance is satisfactory.

### Test equipment required:

- 1000 ml test container and thermometer.
- Digital watch / watch with a second hand for use on ovens with electromechanical timers.

### Important Notes:

- Low line voltage will cause low temperature rise / power output.
- Ovens must be on a dedicated circuit, properly grounded, and polarized. Other equipment on the same circuit may cause a low temperature rise / power output.
- This test and results are not a true IEC705 test procedures and are only intended to provide servicers with an easy means of determining if the microwave oven cooking output is correct.

### Procedure

1. Fill the test container to the 1000 ml line with cool tap water.

**NOTE:** Water temperature should be approximately 60°F / 16°C

2. Using the thermometer, stir water for five to ten seconds; measure, and record the temperature (T1).
3. Place test container of water in the center of oven cavity and close door.
4. Heat the water for a 30-second full power cycle.

**NOTE:** Use a digital watch or a watch with a second hand for ovens with electromechanical timers.

5. At end of the cycle, remove test container. Using the thermometer, stir water for five to ten seconds and record temperature (T2).
6. Subtract the starting water temperature (T1) from the ending water temperature (T2) to obtain the temperature rise ( $\Delta T$ ).
7. If the temperature rise ( $\Delta T$ ) meets or exceeds the minimum, the test is complete. If the temperature rise ( $\Delta T$ ) fails to meet the minimum temperature rise, test the line voltage to verify it is correct. Then repeat steps 1 - 6 making sure to change the water. If the temperature rise ( $\Delta T$ ) fails to meet the minimum temperature rise again the oven will require service.

### Minimum Temperature Rise at Thirty (30) Seconds Run Time

$\Delta T$ (°F)	Cooking Power Output	$\Delta T$ (°F)	Cooking Power Output	$\Delta T$ (°C)	Cooking Power Output	$\Delta T$ (°C)	Cooking Power Output
10	1000	20	2000	5	1000	11	2000
11	1100	21	2100	5.5	1100	11.5	2100
12	1200	22	2200	6.5	1200	12	2200
14	1400	24	2400	7.5	1400	13	2400
17	1700	25	2500	9.5	1700	13.5	2500
18	1800	27	2700	10	1800	15	2700
19	1900	30	3000	10.5	1900	16.5	3000

# Wiring Diagram and Schematic



## WARNING

To avoid risk of electrical shock, personal injury or death; disconnect power to oven and discharge capacitor before servicing, unless testing requires power.

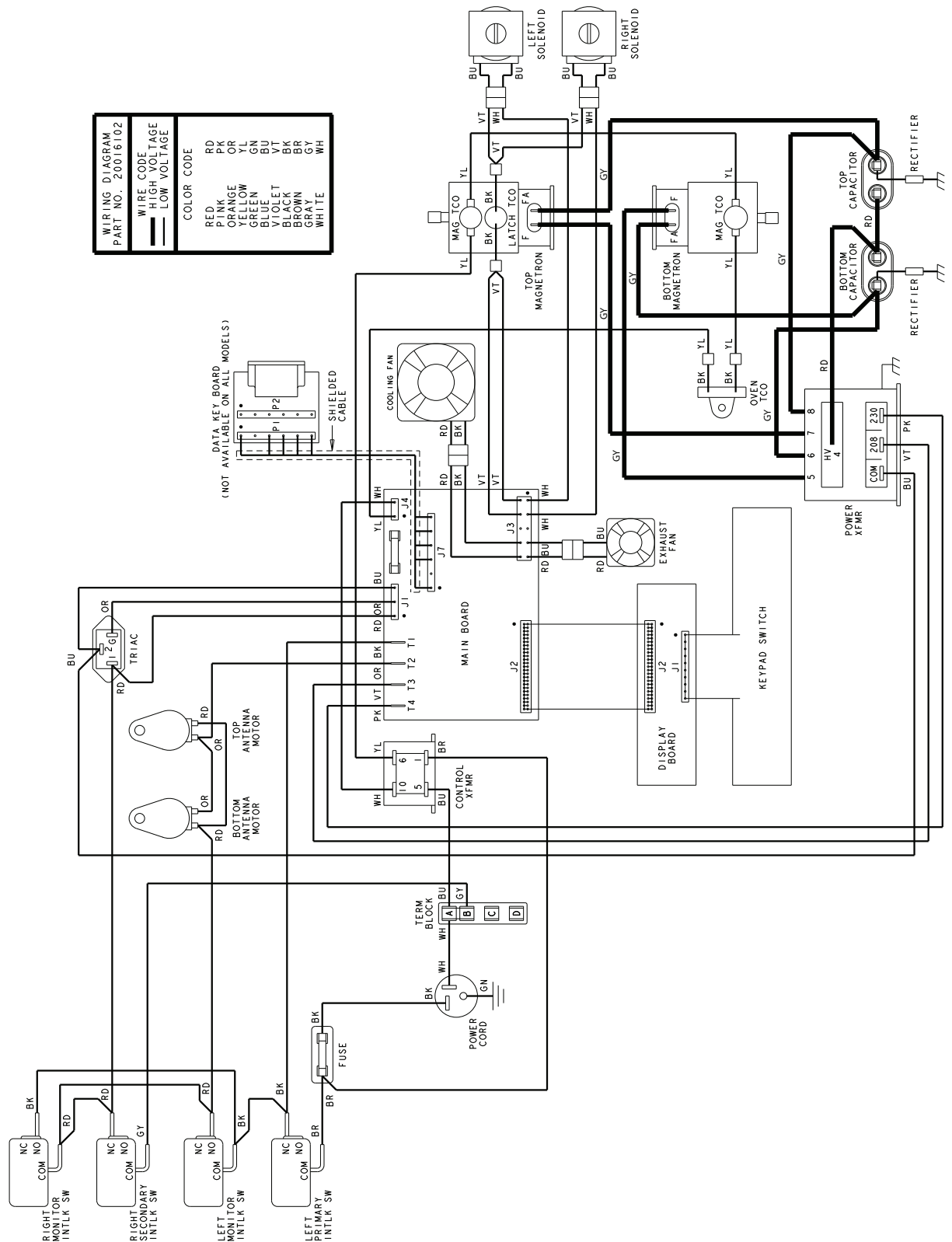

# Wiring Diagram and Schematic



**WARNING**

To avoid risk of electrical shock, personal injury or death; disconnect power to oven and discharge capacitor before servicing, unless testing requires power.

