

INSTRUCTION SHEET

16200049

Description: Triac Relocating Kit # R0000341
For use on 0.6 Compact Microwave Ovens

Special tools needed:

Power drill
7/64 (2.7 mm) drill bit (#35)

Contents:

Quantity	Part #	Description
1	D7681501	Triac
2	M0216517	Screw
1	A0304502	Connector
1	R0195031	Thermal compound
1	R0000342	Jumper wire
1	16200049	Instructions
2	M0321202	Wire tie
1	M0104102	Harness clip

This kit will replace and relocate the triac.

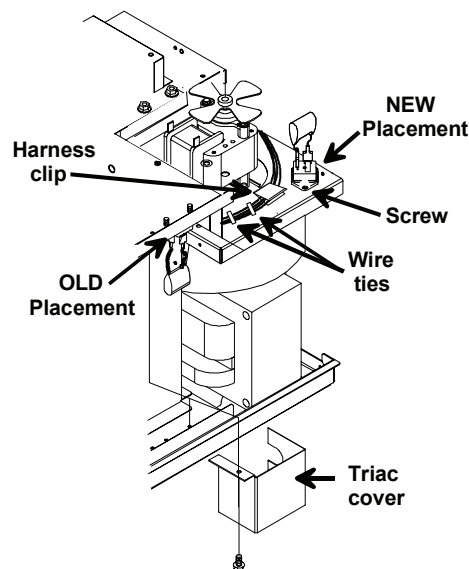

1. Remove outercase and back panel.
2. Pull cardboard triac cover away from cavity to gain access to triac. DO NOT remove cover.
3. Remove wires from harness clip and cut wire ties on harness leading to triac.

ACP, Inc.
225 – 49TH Avenue Drive SW
Cedar Rapids, IA 52404

REV. 0
DATE: 12-7-09
PART #: 16200049
Page 1 OF 2

4. Remove 1 screw securing blower scroll to blower bracket. Position new triac (D7681501) to blower bracket and use this screw to temporarily secure one side of triac.
- NOTE:** It may be necessary to remove harness clip before installing triac.
5. Position other side of triac 1/4 (6 mm) from back edge of blower bracket.

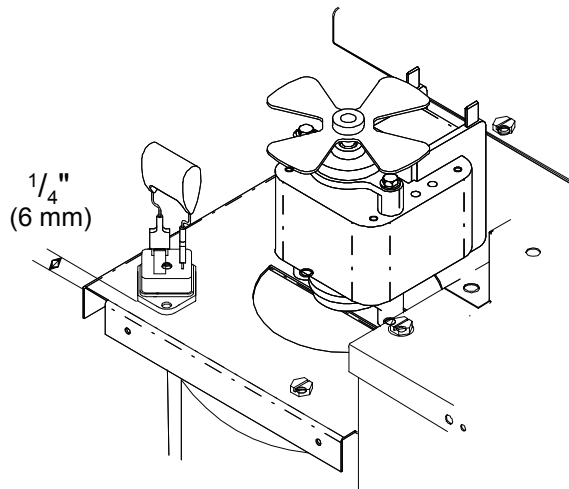

6. Mark and drill a 7/64 (2.7 mm) hole for second triac mounting screw.
Important: use caution when drilling to prevent damage to blower scroll or wheel.
7. Remove triac and apply thin film of thermal compound R0195031 to entire bottom of triac.
8. Secure triac to blower bracket with 2 screws supplied in kit (M0216517).
9. Disconnect DOUBLE BLACK wire from original triac terminal T1. Use caution to prevent damage to snubber.
10. Transfer GREY wire, snubber, and BROWN wire to new triac.

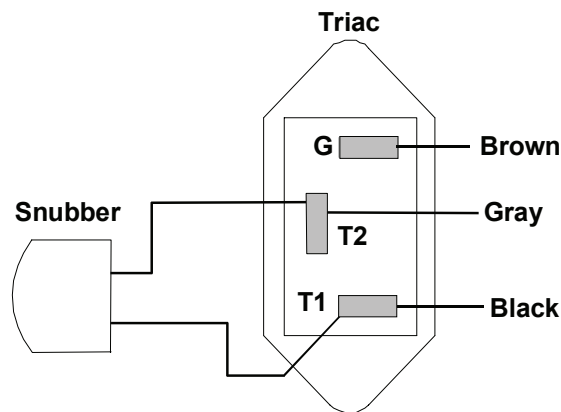

11. Attach jumper wire R0000342 to connector A0304502, then attach connector to DOUBLE BLACK wire removed in step 9.
12. Attach other end of jumper wire to snubber piggyback connector on triac terminal T1.
13. Remove and discard old triac and screws.
14. Use wire ties M0321202 and harness clip M0104102 to dress wires away from fan blade and motor.
15. Return cardboard triac cover to its original position.