

INSTRUCTION SHEET

16200099

Description: Kit, Waveguide-LH # 14119054

Contents:	1 – LH Waveguide Assembly	28 – Nuts
	1 – Telescoping Magnetic Pick up Tool	5 – Studs
	1 – 16200099 Instruction Sheet	

Left Waveguide Replacement

1. Remove the right, top and rear panel from the oven.
2. Remove antenna gear by squeezing two tabs on antenna retainer and remove retainer (Figure 1).

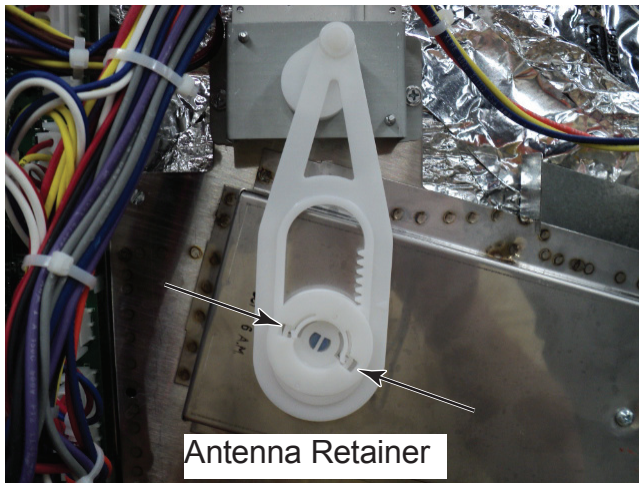

Figure 1

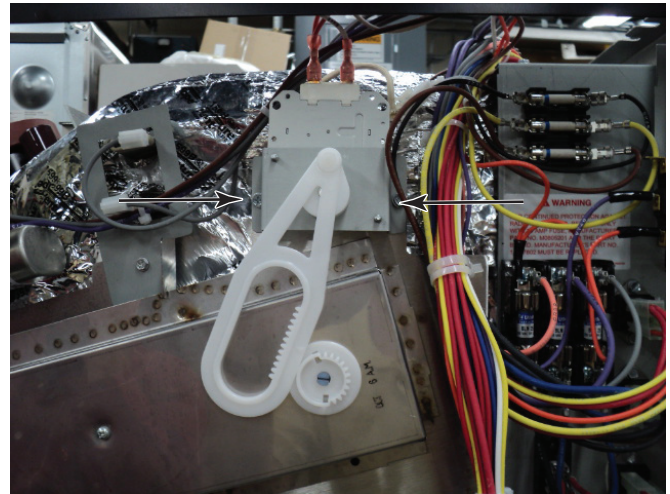

Figure 2

3. Remove two antenna motor mounting screws from bracket (Figure 9). Set antenna motor on top of oven (Figure 2).
4. Cut wire tie holding main wire harness to corner of feed box (Figure 3).
5. Disconnect wires from primary interlock switch (Figure 4).

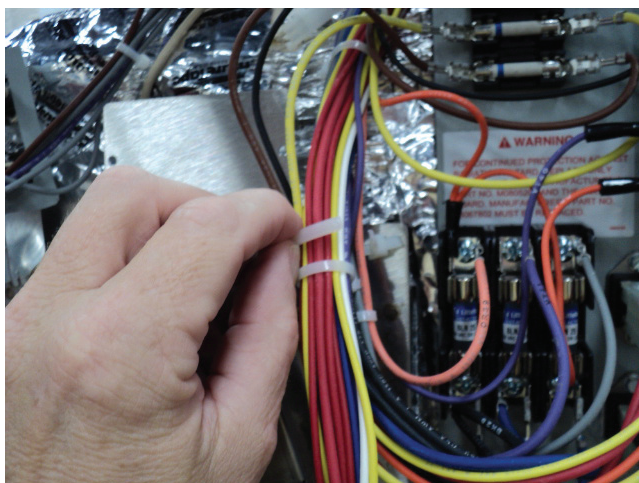

Figure 3

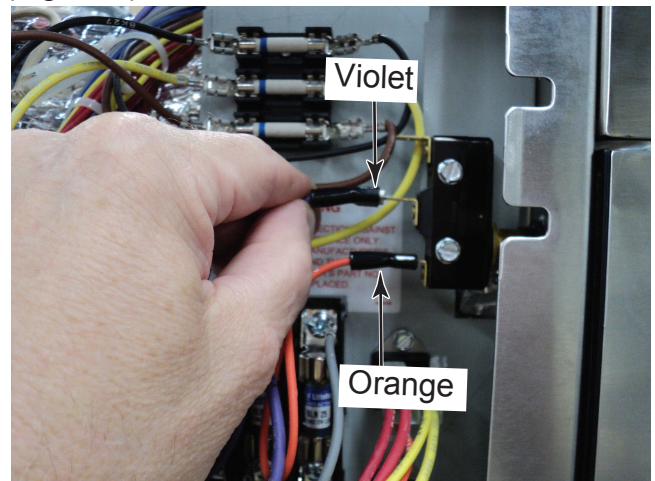

Figure 4

6. Remove two fuse panel mounting screws (Figure 5).
7. Disconnect convection element wires. (Figure 6).

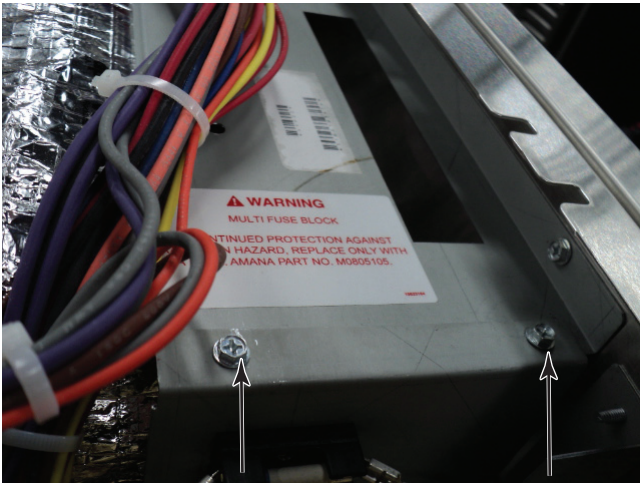

Figure 5

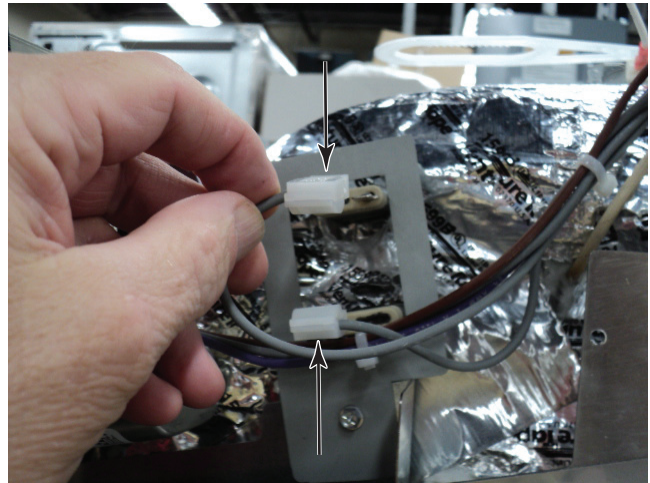

Figure 6

8. Remove convection element bracket mounting screw and remove bracket (Figure 7).
9. Remove four hex head nuts and remove magnetron from waveguide. Do not disconnect wires from magnetron (Figure 8).

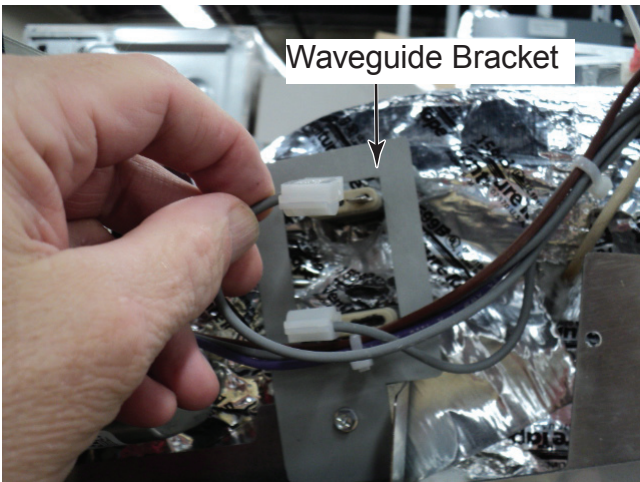

Figure 7



Figure 8

10. Slide wave guide bracket down to the bottom of the wave guide (Figure 9).
11. Remove four screws securing partition panel and move panel out of the way to access feed box (Figure 10)

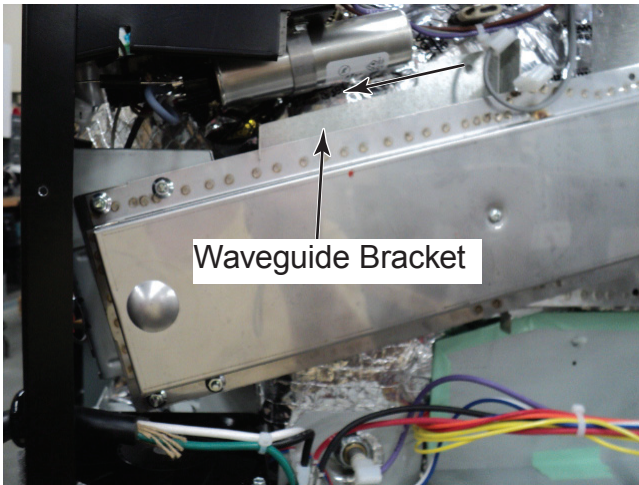

Figure 9

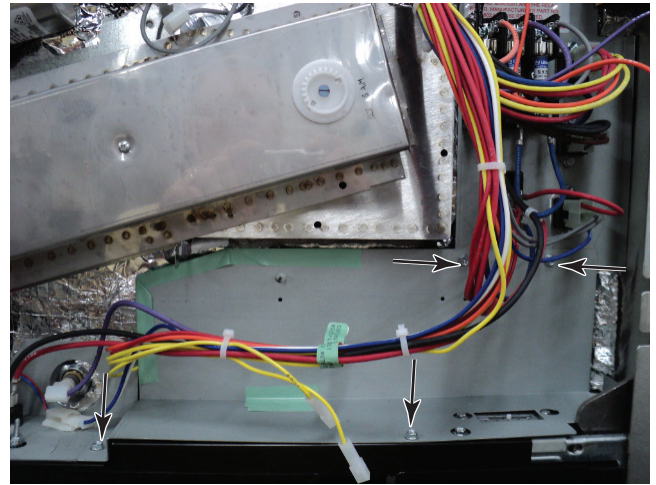

Figure 10

Feed box Removal and Installation

Tools required:

- 3/8" drive socket wrench
- 5/16" socket
- 5/16" open end / box end wrench
- Telescoping magnetic pick up tool (Included in kit)
- Flat blade screwdriver

⚠ CAUTION

- Use care when removing nuts from feed box there are sharp edges present.
- Do not over tighten mounting nuts, we recommend you tighten hex nuts snug to oven then using a 5/16" socket wrench slightly tighten nut. Over tighten nut will cause the mounting stud to strip out.

1. Diagonally cut insulation at each corner of the feed box (Figure 11).
2. Fold insulation back away from feed box exposing the feed box mounting nuts on all four sides of the feed box (Figure 12).

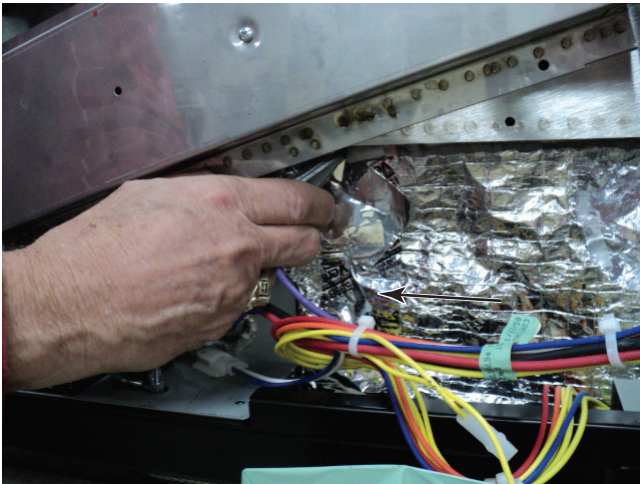

Figure 11



Figure 12

3. It is recommended that you remove the nuts using the following sequence, six nuts along the right side of the feed box (Figure 13).
4. Remove six nuts from the top mounting side of the feed box (Figure 14).

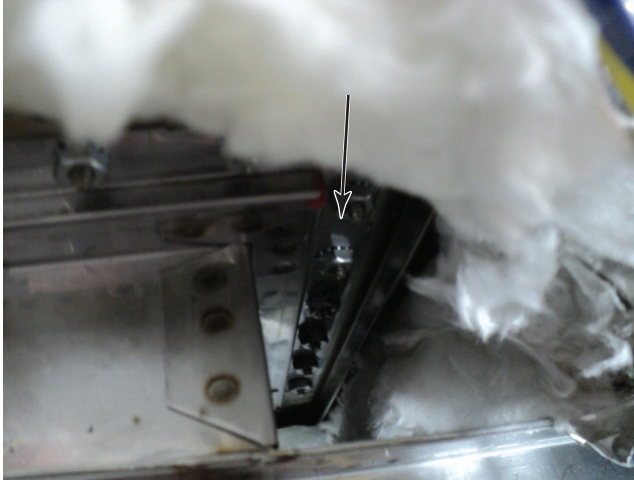

Figure 13

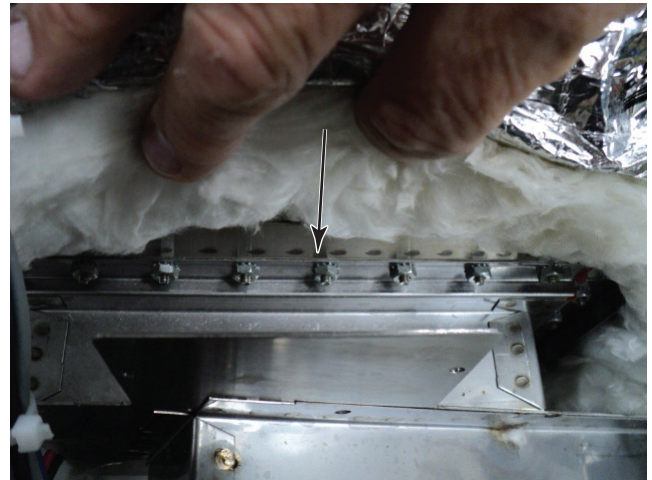

Figure 14

5. Remove the remaining sixteen mounting nuts from the left and bottom side of the feed box.
6. Remove waveguide from oven.
7. Remove waveguide bracket from old waveguide and slide on to new waveguide in kit.
8. Install new waveguide onto oven. Be careful not to get insulation inside cavity around ceramic tray.
9. With waveguide in position install nut in each of outside four corners.
10. It's recommended you start with the six mounting screws on right side between cavity and waveguide.

- Using the telescoping magnetic pickup tool supplied with kit place a nut on the magnetic end and line it up with a stud. Slowly turn the nut onto the stud with your other hand, then remove magnetic tool (Figure 15). Repeat this for the remaining nuts located between the cavity and waveguide.

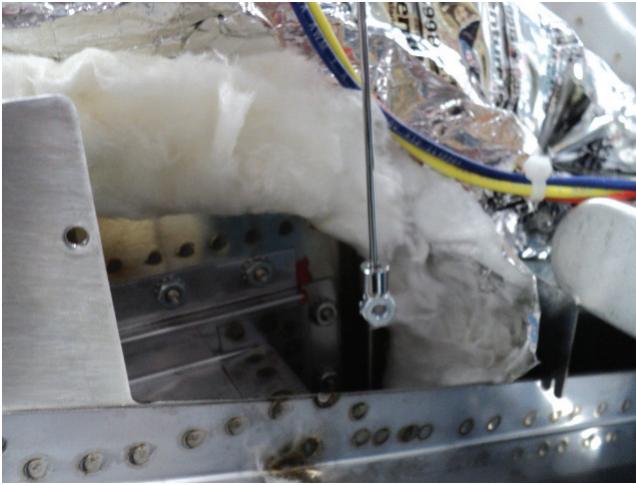

Figure 15

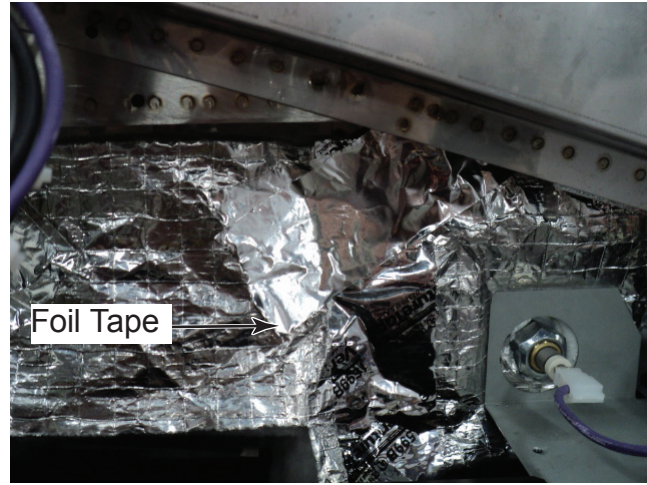

Figure 16

- Reinstall insulation around waveguide and use foil tape included in kit to seal cuts in insulation in all 4 corners of waveguide (Figure 16).
- Reinstall all components, assemblies removed previously. When installing antenna gear verify proper alignment (Figure 17). Rotate gear manual to verify antenna is rotating properly.
- After components have been reinstalled proceed to Oven Test to check for proper operation.

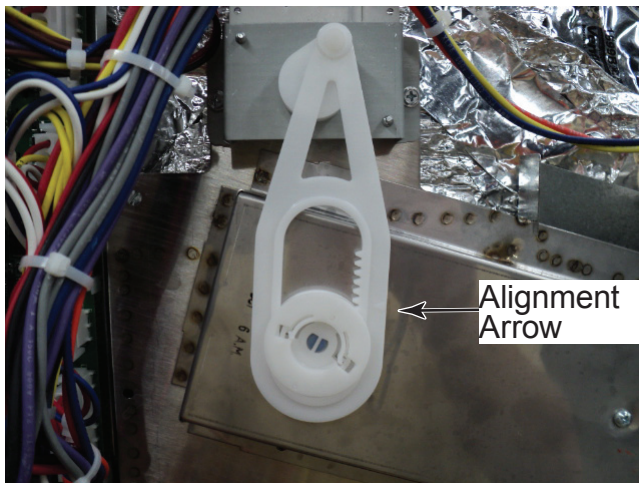



















Figure 17

Oven Test

1. Plug oven in ( icon will appear in about 10 seconds).
2. Press and hold keypad 2 until option 1 appears.
3. Press the back  arrow icon repeatedly until option 15 displays. Display will indicate:

4. Press the up  arrow icon to change from  to .
5. Press green start  icon to lock in change.
6. Press red stop / reset  icon to exit option mode.
7. Place a glass container of water in the oven.
8. Press forward  arrow icon. 1 thru 0 will appear in the display.
9. Press manual cook  icon to place oven in to manual cook mode.
10. Enter a time by pressing number keypads (example 222).
11. Press green start  icon to start cook cycle.
12. At the end of the cycle the water should be heated. Proceed to RF Leakage Test.

RF Leakage Test

Note: You must have an approved RF meter to complete this test.

1. Place 275 ml of water in test bowl and place in oven.
2. Press the forward  arrow icon. Display will show 1 thru 0.
3. Press manual cook  icon to place oven in to manual cook mode.
4. Enter a time by pressing number keypads (example 222).
5. Press green start  icon to start cook cycle.
6. Using the RF probe scan the area around the feed box area of the oven. If less than 1m/w /cm2 is recorded, install top, back and side panels. If excess leakage is recorded recheck mounting nuts for proper tightness.
7. Perform service test to verify complete oven operation.
8. Go back to options (see Oven Test steps 1- 6) and change option 15 microwave only 
back to no microwave  only.