

# INSTRUCTION SHEET

# 16200021

**Description:** 50 Hz HV/LV Board Conversion  
**Kit #14080010 / 14090022**

**Kit Contents:**

- 1 – 16200021 Instruction Sheet
- 1 – 59002070 HV/LV Board
- 1 – 59004020 / 59004062 Touch Panel Assy
- 1 – 13054301 Switch, Interlock Assy
- 1 – 13017714 Jumper Wire
- 1 – 12905301 Harness PC Board
- 1 – 12905401 Harness Keyboard
- 1 – 20028401 Terminal, Piggyback
- 6 – M0321210 Wire Ties
- 1 – 16200036 / 16200038 Label

1. Unplug or disconnect power to oven.
2. Remove outercase, touch panel assembly, and hv/lv board.
3. Mount new hv/lv board from kit replacing old hv/lv board.

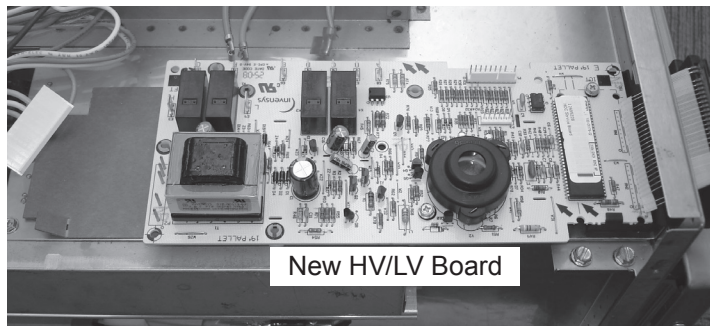

4. Plug harness pc board into hv/lv board and harness pc board into cabinet harness.

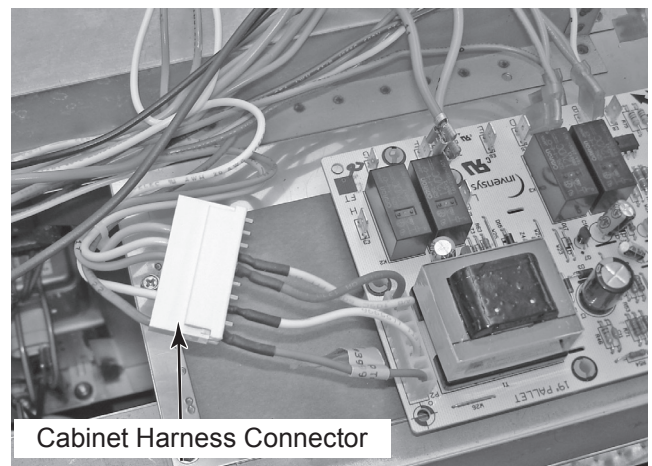
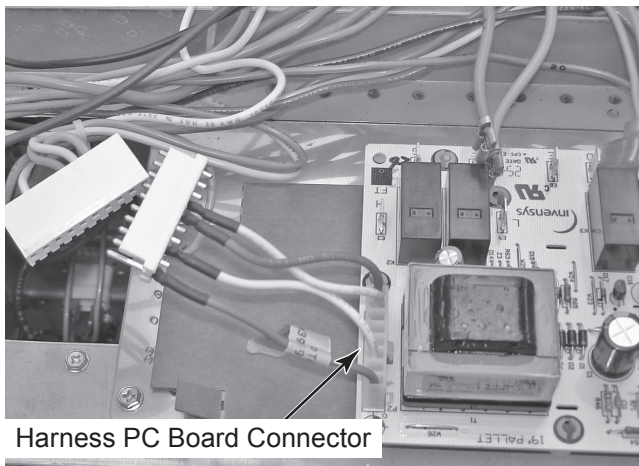

ACP, Inc.  
225 – 49TH Avenue Drive SW  
Cedar Rapids, IA 52404

REV. 3  
DATE: 7-13-09  
PART #: 16200021  
Page 1 OF 6

5. Plug new harness keyboard board connector from kit to hv/ lv board and harness keyboard connector into ribbon connector on new touch panel assembly thru opening behind oven display.

**Note:** Make sure open pins align from hv/ lv board to keyboard harness and ribbon connector to keyboard harness or keypad will not function correctly.

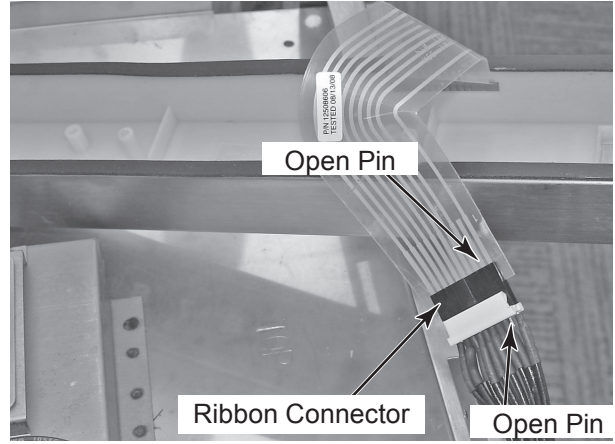
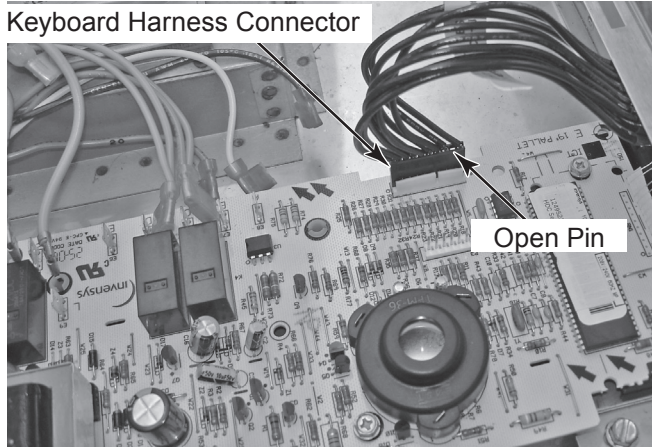

6. Carefully fold ribbon connector from touch panel assembly and reinstall new touch panel to oven cavity making sure not to pinch any wires or ribbon connector.
7. Disconnect old interlock assembly, remove and replace with new interlock assembly from kit.
8. Connect violet and yellow wires to primary switch, connect double black and double white wires to secondary switch and connect single black wire to monitor switch on new interlock switch assembly.

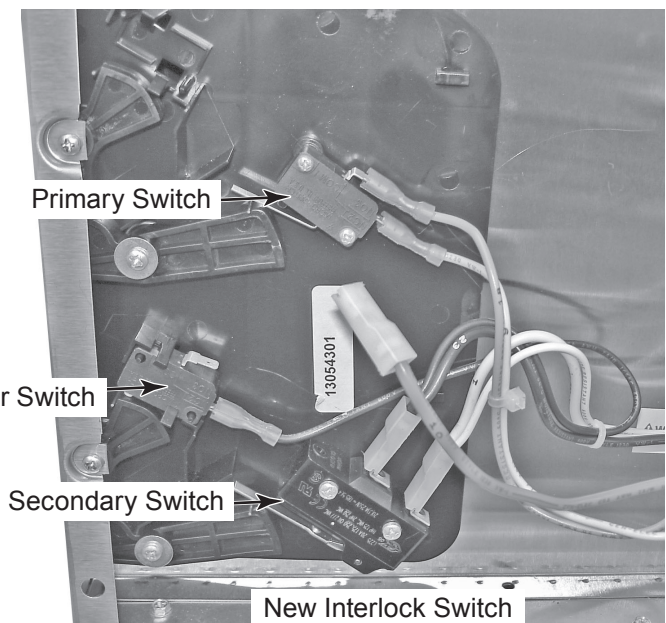
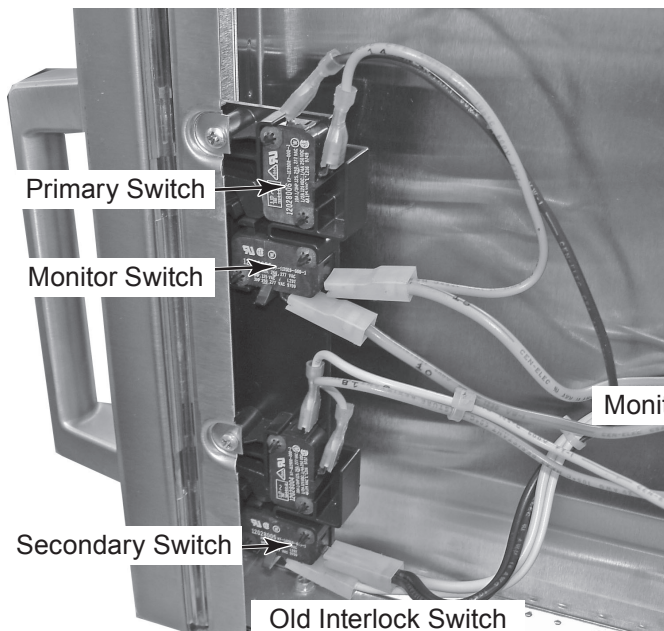

9. Remove all wire ties used on wire harness between new interlock assembly and new hv/lv board assembly.
10. Remove light blue wire with one double end from harness between new interlock assembly to new hv/lv board assembly and discard wire.

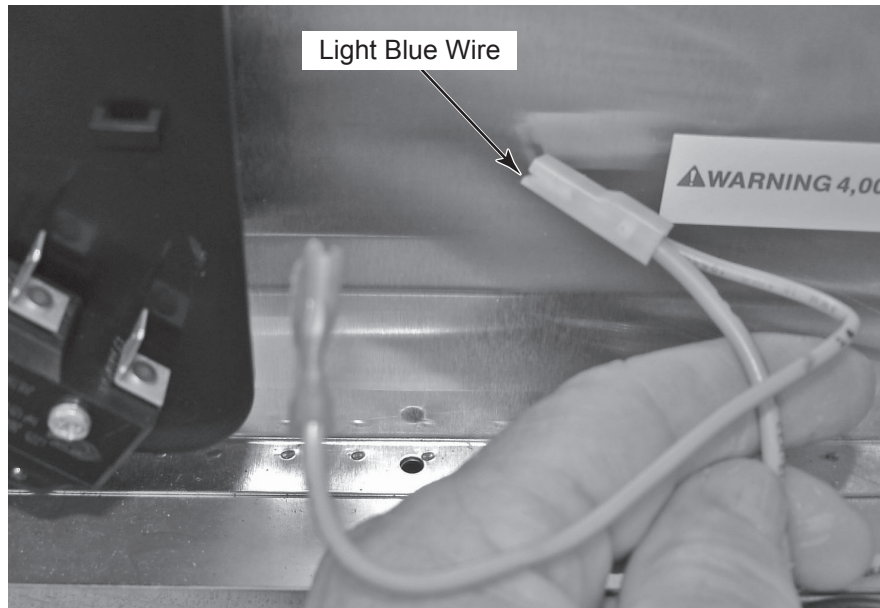

11. Relocate red interlock switch wire from original interlock switch to (F) terminal on new hv/lv board.

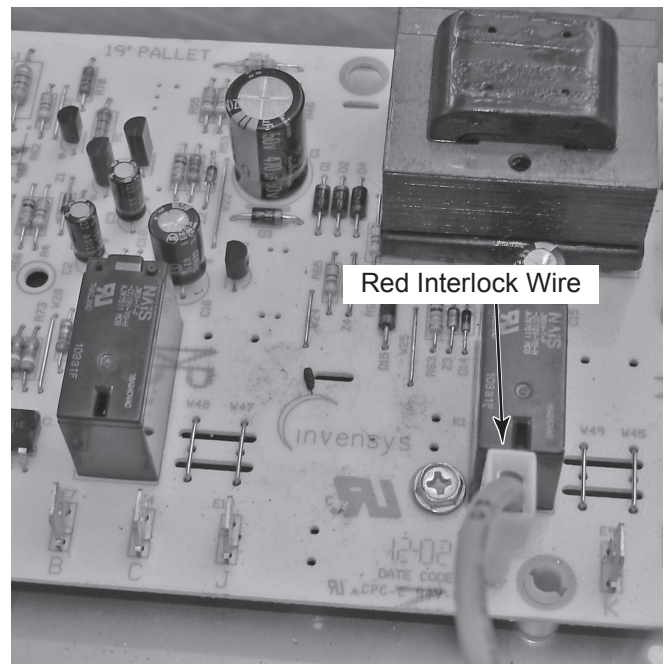
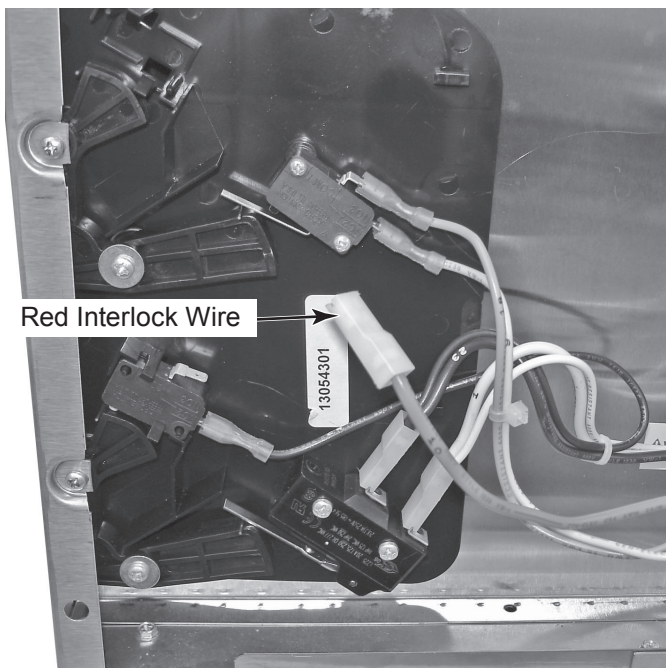

12. Connect brown wire terminal to (A), grey wire terminal to (B), double red wire terminal to (C), double orange wire terminal to (J), on new hv/lv board.

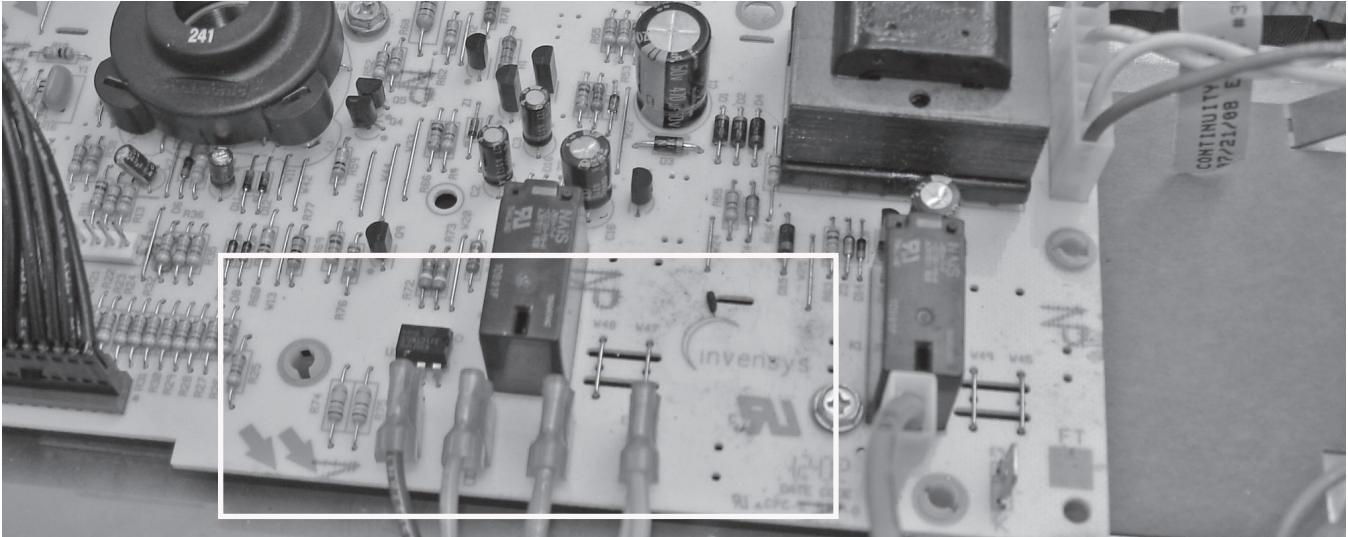

13. Replace insulated flag terminal on blue jumper wire in kit with stack terminal supplied in kit.

14. Connect new blue wire stack terminal and red wire terminal from hv transformer to (K) terminal on new hv/lv board and other end to common terminal on monitor switch of new interlock switch routing the blue wire with wire harness to interlock switch.

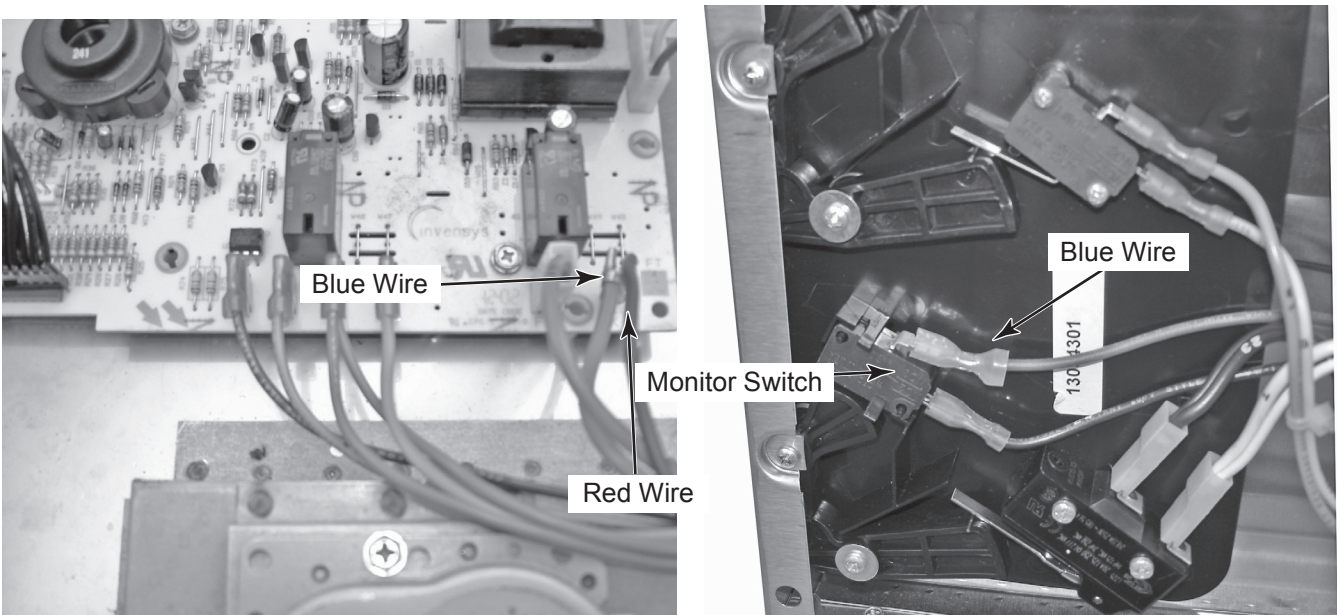

15. Remove double black wire terminal from terminal splice next to triac and cut small black wire that went to old hv/lv board and discard small black wire and replace large black wire terminal into terminal splice leading to triac.

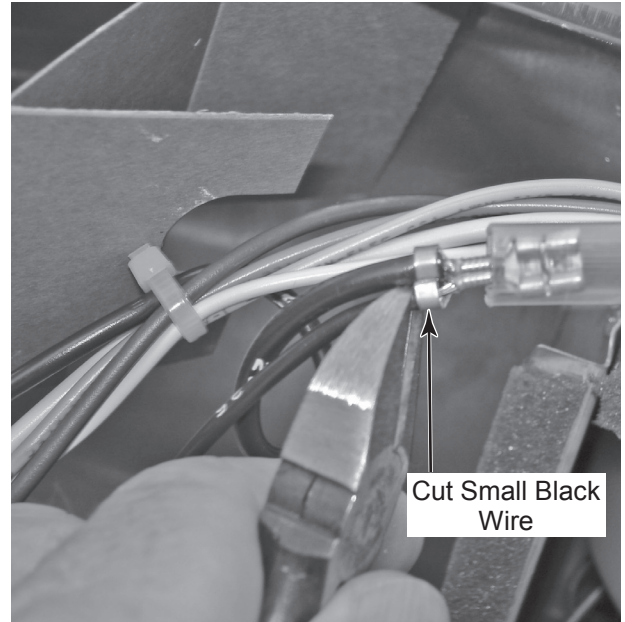
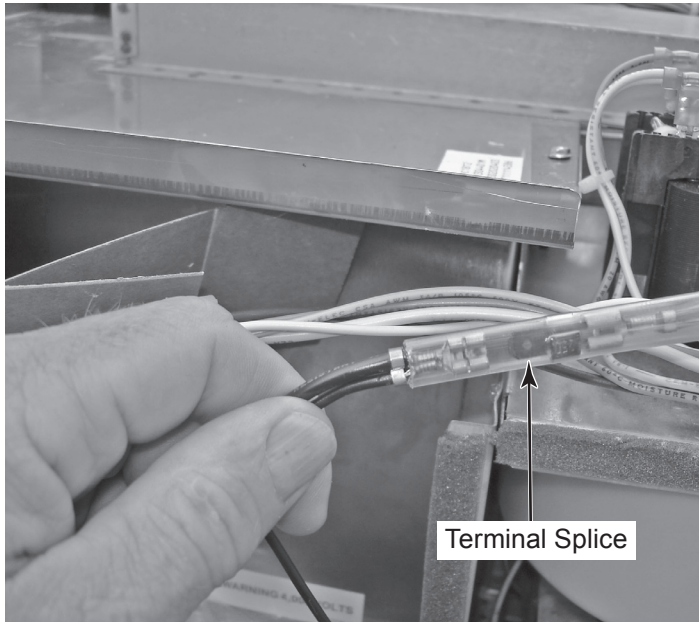

16. Wire tie harness between new hv/lv board and new interlock switch with wire ties provided in kit.

**Note:** Trim ends off of wire ties and dress wire harness so it does not come into contact with fan and outercase.

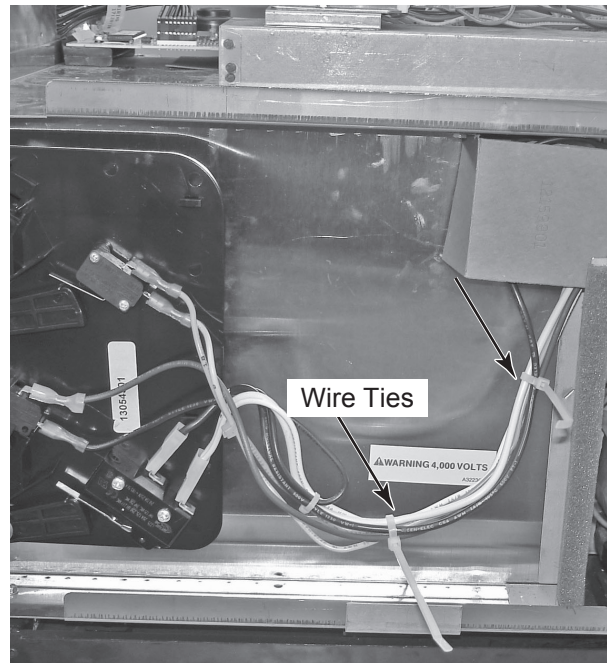
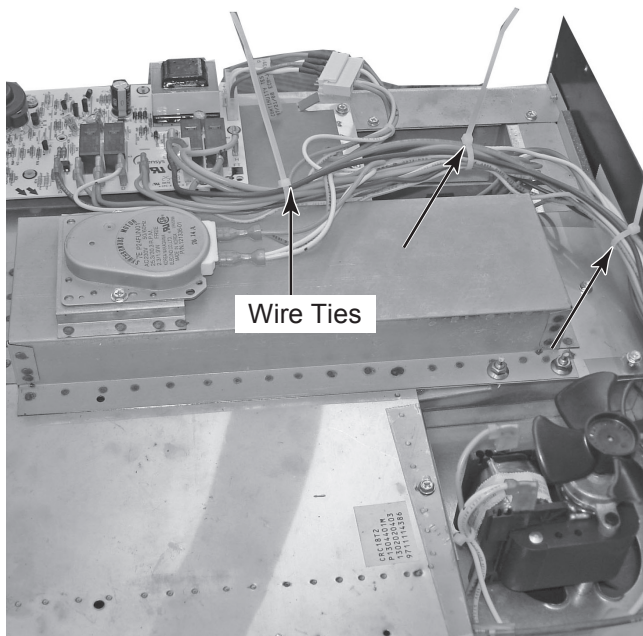

17. Replace outercase and check unit for proper operation.

18. Place label on unit to show it has been modified.

ACP, Inc.  
225 – 49TH Avenue Drive SW  
Cedar Rapids, IA 52404

REV. 3  
DATE: 7-13-09  
PART #: 16200021  
Page 5 OF 6

# New Wiring Diagram

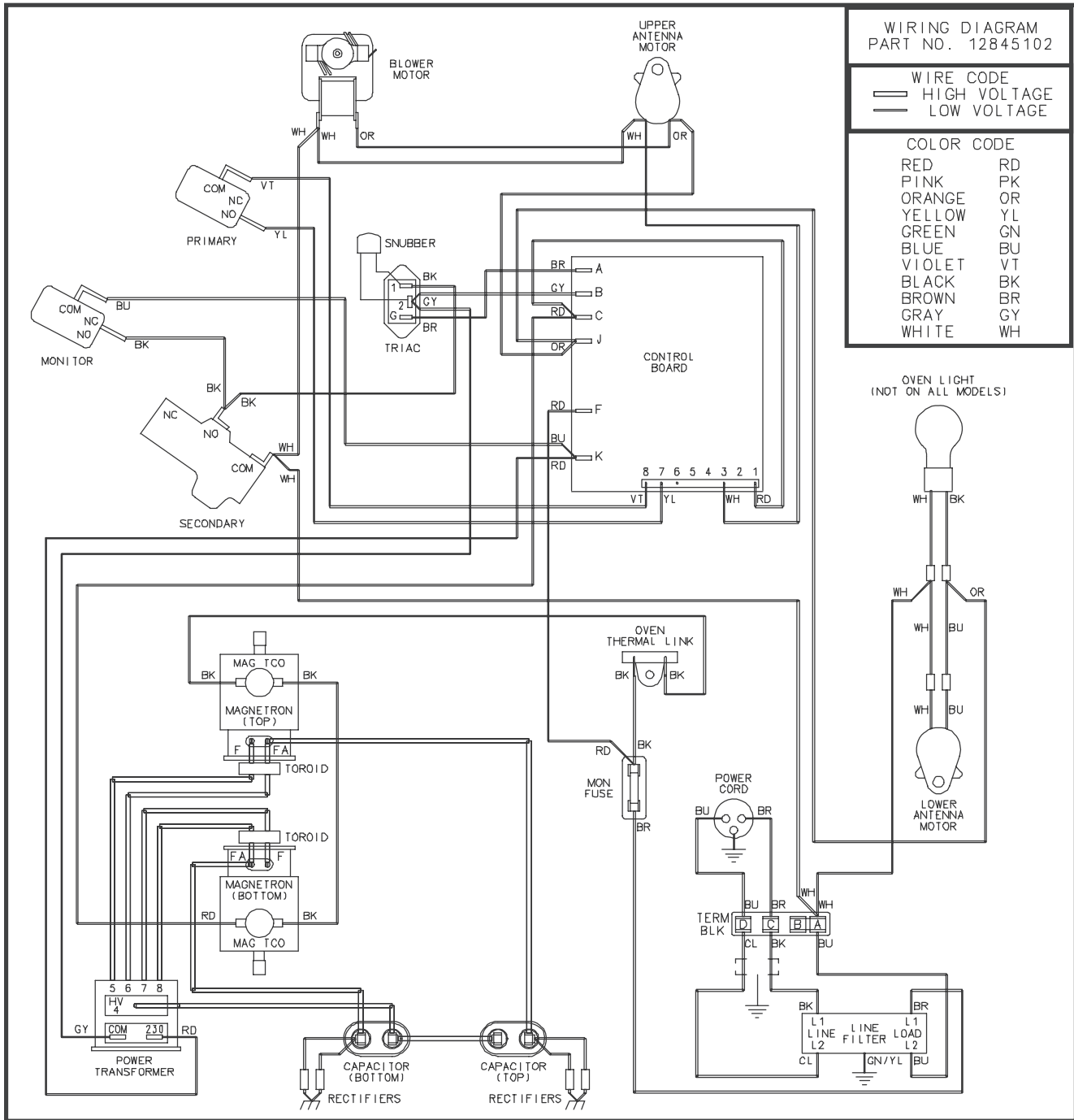

ACP, Inc.  
 225 - 49TH Avenue Drive SW  
 Cedar Rapids, IA 52404

REV. 3  
 DATE: 7-13-09  
 PART #: 1620021  
 Page 6 OF 6