

Commercial Microwave—Technical Information

208/230 V, 60 Hz Models

ACE208
ACE230

P1324410M
P1324412M

ACE208D
ACE230SB

P1324411M
P1324413M

- Due to possibility of personal injury or property damage, always contact an authorized technician for servicing or repair of this unit.
- Refer to Service Manual RS2220002 for installation, operating, testing, troubleshooting, and disassembly instruction.



CAUTION

All safety information must be followed as provided in Service Manual RS2220002.



WARNING



To avoid the risk of electrical shock, personal injury or death; disconnect power to oven and discharge capacitor before servicing, unless testing requires it.

Models	ACE208		ACE208D		ACE230 ACE230SB	
Power Source						
Voltage AC	208 VAC		208 VAC		230 VAC	
Amperage (Single Unit)	20 A		20 A		20 A	
Frequency	60 Hz		60 Hz		60 Hz	
Single Phase, 3 wire grounded	X		X		X	
Receptacle	6-20R		L6-20R		6-20R	
Plug	6-20P		L6-20P		6-20P	
Power Output – Microwave						
Nominal microwave energy (IEC705)	1000 Watts		1000 Watts		1000 Watts	
Traditional test method	850 Watts		850 Watts		850 Watts	
Operating Frequency	2450 MHz		2450 MHz		2450 MHz	
Power Consumption						
Microwave only	1800 Watts		1800 Watts		1800 Watts	
Convection only	2700 Watts		2700 Watts		2700 Watts	
Combination	3300 Watts		3300 Watts		3300 Watts	
Dimensions						
Cabinet (in / cm)						
Width	19 1/4"	49 cm	19 1/4"	49 cm	19 1/4"	49 cm
Height	18"	46 cm	18"	46 cm	18"	46 cm
Depth	21 1/8"	54 cm	21 1/8"	54 cm	21 1/8"	54 cm
Oven Interior (in / cm)						
Width	13"	33 cm	13"	33 cm	13"	33 cm
Height	10 1/2"	27 cm	10 1/2"	27 cm	10 1/2"	27 cm
Depth	15"	38 cm	15"	38 cm	15"	38 cm
Weight						
Crated	112 lbs.		112 lbs.		112 lbs.	
Uncrated	97 lbs.		97 lbs.		97 lbs.	

Component Testing Procedures

⚠ WARNING

To avoid risk of electrical shock, personal injury or death; disconnect power to oven and discharge capacitor before servicing, unless testing requires it.

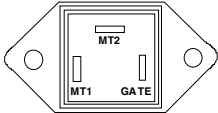
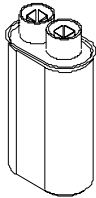
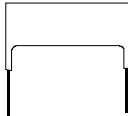
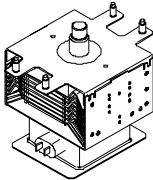
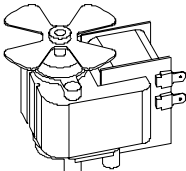
Illustration	Component	Test	Results
	Thermal cutout	Disconnect all wires from TCO. Measure resistance across terminals. Control TCO..... Fan TCO..... Magnetron TCO.....	Open at 300°F (149°C) and closed at 257°F (125°C) Closed at 160°F (71°C) and open at 125°F (52°C) Open at 235°F (113°C) and closed at 150°F (66°C)
	Diode	Discharge Capacitor Remove diode lead from capacitor and connect ohmmeter. Reverse leads for second test.	Infinite resistance should be measured in one direction and 50KΩ or more in the opposite direction. NOTE: Ohmmeter must contain a battery of 6 volts minimum.
	Triac	Disconnect wires to triac. Measure resistance from: MT1 to MT2 MT1 to Gate..... MT2 to Gate..... All terminals to ground	Caution - Do not operate oven with wire to terminal MT2 removed. Infinite Approximately 15 Ω, then reverse meter leads 30 Ω Infinite Infinite
Triac 1 (top) is for front element Triac 2 (middle) is for rear element Triac 3 (bottom) is for microwave		Measure voltage from: MT1 to Gate	0.8 VAC when energized. If no voltage, check H.V. board and wiring.
	Capacitor	Discharge Capacitor Remove wires from capacitor terminals and connect ohmmeter, set on highest resistance scale to terminals. Also check between each terminal and capacitor case.	Between Terminals: Meter should momentarily deflect towards zero then return to over 5 MΩ. If no deflection occurs, or if continuous deflection occurs, replace capacitor. Terminal to Case: Infinite resistance
	Snubber assembly	Disconnect wires to snubber. Measure resistance across terminals.	Infinite
	Magnetron	Discharge Capacitor Remove wires from magnetron and connect ohmmeter to terminals. Also check between each terminal and ground.	Between Terminals: Less than 1 Ω Each terminal to ground measures Infinite resistance. Note: This test is not conclusive. If oven does not heat and all other components test good replace the magnetron and retest.
	Microwave blower motor	Remove all wires from motor. Measure resistance across coil.	Approximately 33 Ω

Component Testing Procedures



WARNING

To avoid risk of electrical shock, personal injury or death; disconnect power to oven and discharge capacitor before servicing, unless testing requires it.

Illustration	Component	Test	Results									
	Transformer	<p>Discharge Capacitor Remove all wires from terminals.</p> <p>Measure resistance from: 230 to COM 208 to COM 230 to Ground 208 to Ground Terminal 5 to 6 Terminal 4 to Ground</p>	<p>Less than 1 Ω Less than 1 Ω Infinite Infinite Less than 1 Ω Approximately 70 Ω</p>									
<p>Door Closed</p> <p>2 — ● — 3 Secondary 4 — ● — 5 Primary 7 — ● — 8 Monitor</p>	Interlock switch	<p>Disconnect wires to switch.</p> <p>With door open measure resistance from: Terminal 2 to 3 Terminal 4 to 5 Terminal 7 to 8</p> <p>With door closed measure resistance from: Terminal 2 to 3 Terminal 4 to 5 Terminal 7 to 8</p>	<p>Infinite Infinite Indicates continuity</p> <p>Indicates continuity Indicates continuity Infinite</p>									
	Convection blower motor	<p>Remove wires from motor.</p> <p>Measure resistance across terminals A and B.</p>	Approximately 20 Ω									
	Heating element assembly	<p>Disconnect wires from terminals.</p> <p>Measure resistance across heating element.</p> <p>Front element 1200 W</p> <p>Rear element 1500 W</p>	<p>Indicates continuity</p> <table border="0"> <tr> <td></td> <td>ACE208</td> <td>ACE230</td> </tr> <tr> <td>Front element</td> <td>35 Ω</td> <td>43 Ω</td> </tr> <tr> <td>Rear element</td> <td>29 Ω</td> <td>35 Ω</td> </tr> </table>		ACE208	ACE230	Front element	35 Ω	43 Ω	Rear element	29 Ω	35 Ω
	ACE208	ACE230										
Front element	35 Ω	43 Ω										
Rear element	29 Ω	35 Ω										
	Resistance thermal device (RTD)	<p>Temperature</p> <p>32°F.....</p> <p>350°F.....</p>	<p>Resistance</p> <p>1000 Ω</p> <p>1654 Ω</p>									
	Lamp receptacle	Test continuity of receptacle terminals.	Indicates continuity with bulb screwed in.									

Component Testing Procedures

⚠ WARNING

To avoid risk of electrical shock, personal injury or death; disconnect power to oven and discharge capacitor before servicing, unless testing requires it.

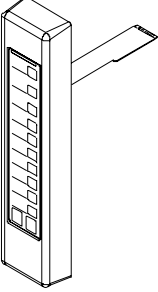
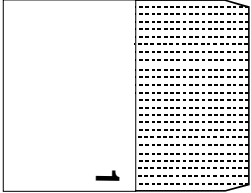
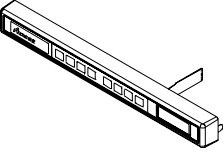
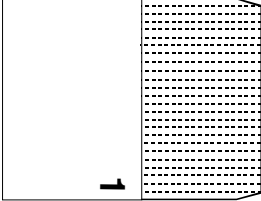
Illustration	Component	Test	Results		
	Side touch panel	Continuity is indicated as 100 Ω and below. 	Pad 1 2 3 4 5 6 7 8 9 0 Start Stop/Reset	Trace 3 & 5 3 & 6 3 & 7 3 & 8 3 & 9 4 & 5 4 & 6 4 & 7 4 & 8 4 & 9 5 & 6 6 & 9	Measurement Continuity Continuity Continuity Continuity Continuity Continuity Continuity Continuity Continuity Continuity Continuity Continuity
	Top touch panel	Continuity is indicated as 100 Ω and below. 	Pad Preheat Time Temp Power Level Stage Program Save Hidden Pad	Trace 3 & 4 5 & 7 7 & 8 5 & 8 5 & 9 6 & 7 8 & 9	Measurement Continuity Continuity Continuity Continuity Continuity Continuity Continuity
Wire harness	High voltage board to display module harness	Test continuity of wires.	Indicates continuity		

Display board

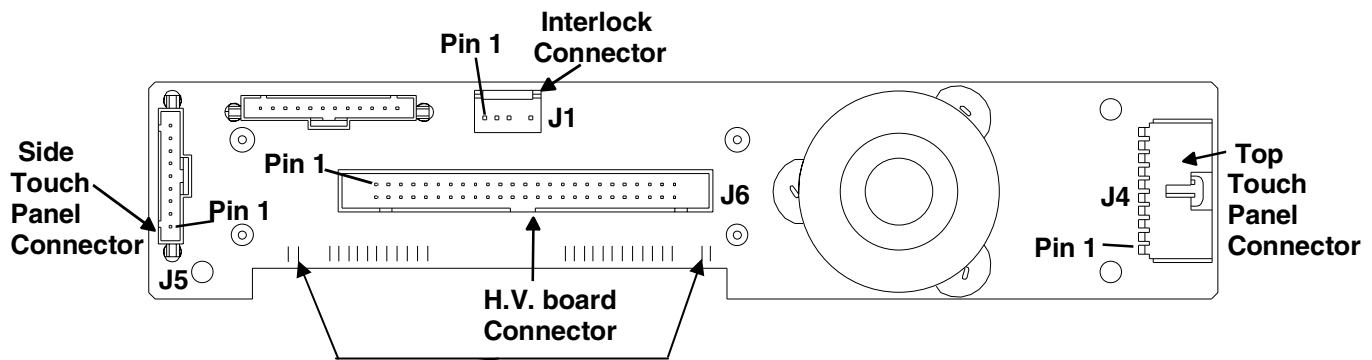

3.5 VAC should be indicated whenever the oven is plugged into a power supply.

If voltage is present and no display is indicated, replace display board.

If no voltage is present, check wire harness connections and H.V. board.

Component Testing Procedures



WARNING

To avoid risk of electrical shock, personal injury or death; disconnect power to oven and discharge capacitor before servicing, unless testing requires it.

H.V. board

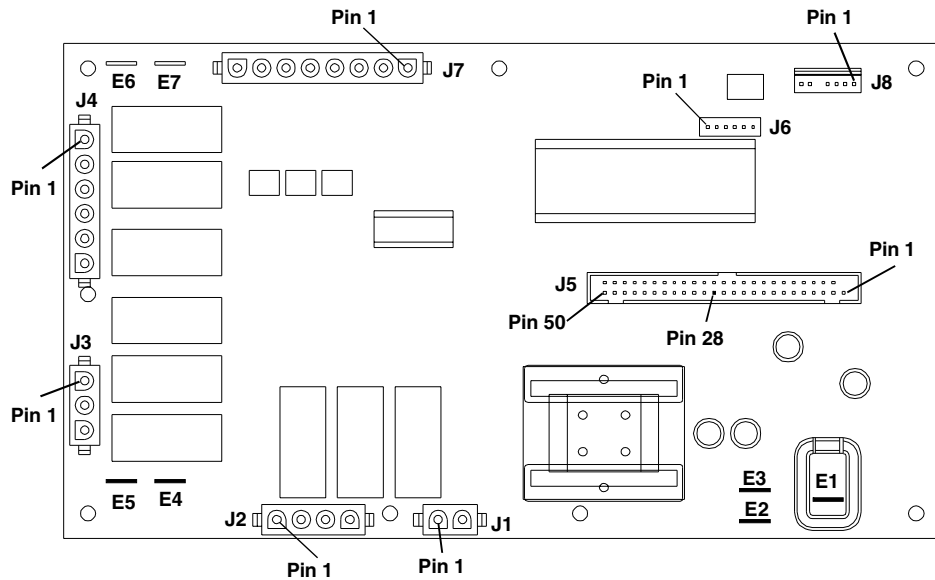

In straight convection mode, both elements operate simultaneously.

In combination mode, the rear element will operate simultaneously with either the microwave or front element.

Function	Test Set-Up	Meter Setting	Probe Placement	Results
Input to H.V. board	At H.V. board	Volts	J1 pin 1 (Black wire) & J1 pin 2 (Red wire)	Line voltage
Output to display board	Disconnect J5 connector	Volts	J5 pin 28 & J5 pin 50	- 24 VDC

NOTE: For the following test, place oven in Service Test Mode (see page 7 and 8).

Relay	Function	Test Set-Up	Meter Setting	Probe Placement	Results
K1	Cooling fan	Disconnect J2 connector	Ohms	J1 pin 1 (Black wire) & J2 pin 4	Test mode 5 off – no continuity Test mode 5 on – < 1 Ω
K2	Convection motor	Disconnect J2 connector	Ohms	J1 pin 1 (Black wire) & J2 pin 3	Test mode 4 off – no continuity Test mode 4 on – < 1 Ω
K3	Cavity light	Disconnect J2 connector	Ohms	J2 pin 1 & J2 pin 2	Test mode 6 off – no continuity Test mode 6 on – < 1 Ω
K4	Heater A (front)	Disconnect J3 connector	Ohms	E4 & J3 pin 3	Test mode 2 off – no continuity Test mode 2 on – < 1 Ω
K7	Microwave	Disconnect J4 connector	Ohms	J4 pin 4 & J4 pin 5	Test mode 3 off – no continuity Test mode 3 on – < 1 Ω
K9	Heater B (rear)	Disconnect J4 connector	Ohms	E6 & J4 pin 1	Test mode 1 off – no continuity Test mode 1 on – < 1 Ω

Component Testing Procedures



To avoid risk of electrical shock, personal injury or death; disconnect power to oven and discharge capacitor before servicing, unless testing requires it.

Power Test (TRADITIONAL TEST METHOD)

Test Equipment Needed:

- Amana power test kit R0157397 or
- Menumaster power test kit M95D5.

NOTE: Oven must be cold, before performing this test.

1. Place one rack in the oven using lowest rack position.
2. Fill the plastic container to the bottom of the 1000 ml. lines with cool tap water.
3. Using the thermometer; Fahrenheit or Centigrade, stir the water, measure and record the water temperature.
IMPORTANT: Initial water temperature should be approximately 60°F (20°C).

4. Place the container on the center of the oven shelf and heat the water for 63 seconds.
 - a. Oven must be in STANDBY mode.
 - b. Close the door.
 - c. Press Hidden Pad, 1, 3, 5, 7, 9.
 - d. Press 3 to activate microwave mode.
 - e. Display counts up to 62 seconds, and unit shuts off.
 - f. Open the door.



5. Stir the water, measure and record the temperature of the water after heating time is completed.
6. Subtract the starting water temperature (Step 3) from the ending water temperature (Step 5) to obtain the temperature rise.
7. Refer to the Temperature Chart.

NOTE: Variation or errors in the test procedure will cause a variance in the temperature rise indication. Additional power tests should be made if temperature rise appears marginal.

NOTE: Low line voltage will cause lower power output (temperature rise).

NOTE: Always perform 3 tests for accuracy. Change water after each test.

Traditional Power Test Temperature Chart

SIXTY-TWO (62) SECONDS run time chart for units less than 1550 Watts cooking power

ΔT (°F)	Cooking Power Output	ΔT (°F)	Cooking Power Output	ΔT (°C)	Cooking Power Output	ΔT (°C)	Cooking Power Output
15	585	21	814	8	560	12	840
16	624	22	852	9	630	13	910
17	663	23	891	10	700	14	980
18	697	24	930	11	770	15	1050
19	736	25	969				
20	775	26	1007				

Service Test

WARNING

To avoid risk of electrical shock, personal injury or death; disconnect power to oven and discharge capacitor before servicing, unless testing requires it.

NOTE: Unit must be in STANDBY mode.

To Enter Service Mode, oven door must be closed.

NOTE: Pads will not beep when pressed.



Press Hidden Pad

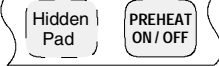

Then



Press

Display

Component Evaluation

0 = Deactivated
1 = Activated

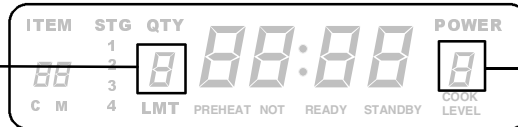

Indicates Service Mode

Displays actual Amperage

1

Toggles Element B (Rear) ON/OFF.



Timer counts up to 99 seconds.

If no Amperage, check:

- Heating element
- Triac 2 (middle)
- H.V. board (relay K9 and triac 2 drive voltage)
- Wiring

Displays actual Amperage

2

Toggles Element A (Front) ON/OFF.



Timer counts up to 99 seconds.

If no Amperage, check:

- Heating element
- Triac 1 (top)
- H.V. board (relay K4 and triac 1 drive voltage)
- Wiring

Displays actual Amperage

3

Toggles Microwave ON/OFF.



Timer counts up to 62 seconds and unit shuts off.

If no Amperage, check for line voltage at H.V. transformer primary winding.

If no voltage, check:

- Interlock switch (secondary)
- Magnetron TCO
- Triac 3 (bottom)
- H.V. board (relay K7 and triac 3 drive voltage)
- Wiring

If voltage is present, check H.V. components and wiring.

4

Toggles Convection Fan ON/OFF.



If no fan operation, check:

- Convection fan motor and wheel
- H.V. board (relay K2)
- Wiring

Service Test

! WARNING

To avoid risk of electrical shock, personal injury or death; disconnect power to oven and discharge capacitor before servicing, unless testing requires it.

Press →

Display

Component Evaluation

5

Toggles Cooling Fan ON/OFF.



If no fan operation, check:

- Cooling fan motor and wheel
- H.V. board (relay K1)
- Wiring

6

Toggles Oven Light ON/OFF.



If no light operation, check:

- Oven light
- H.V. board (relay K3)
- Wiring

7

Displays # of Magnetron Hours.



8

Displays # of Door Cycles with a 1 to 1 ratio rounded to the nearest ten



9

Clears Hours and Cycles (press START to activate) (Resets to 0).



0

Displays current Temperature OFFSET.



TEMP

Display current oven Temperature as sensed by RTD.

Test Modes



WARNING

To avoid risk of electrical shock, personal injury or death; disconnect power to oven and discharge capacitor before servicing, unless testing requires it.

Convection Temperature Test

NOTE: It is absolutely necessary to own and use a thermocouple type oven tester to accurately measure oven temperature. No other type of thermometer can take its place.

NOTE: Before testing an oven to check calibration, inspect the RTD for proper mounting.

1. Place one wire rack in center position. Remove any other racks and utensils.
2. Clip thermocouple to the center rack and run lead outside oven door, or wrap thermocouple around rack and have the tip of thermocouple extend upward towards top of cavity approximately 1".
3. Press *PREHEAT ON/OFF* pad.
4. Press *PROGRAM SAVE* pad.
5. Press *TEMP* pad.
6. Enter 450°F.
7. Allow oven to cycle one time.
8. Record high and low peaks from next two cycles.

NOTE: Display **does not** indicate if heating elements are on or off.

Example:

	<u>LOW</u>	<u>HIGH</u>
Cycle 1	440°F	460°F
Cycle 2	439°F	461°F
	879°F +	921°F = 1800°F

$$1800^{\circ}\text{F} / 4 = 450^{\circ}\text{F} \text{ average temperature}$$

If the average temperature is too high or too low the oven temperature offset needs to be calibrated.

Convection Temperature Calibration

NOTE: It is normal for the average oven temperature to vary from the oven setting by as much as 25°F. Difference will not effect cooking since recipes are written with this difference in mind.

Calibration

NOTE: Door must be closed and unit must be in STANDBY mode.



1. Press *HIDDEN PAD*.
2. Press pads 1,3,5,7, 9.
3. Press "0" pad.



NOTE: Display will show the current offset setting.

4. Press the "0" pad to change the offset.

NOTE: Offset temperature range is +40°F to -40°F and advances in 2 and 3° increments.

5. Press *STOP/RESET* pad to save offset changes.

NOTE: Retest the oven after any offset changes are made.

Example:

- Oven temperature is set for 450°F
- Average of temperature test is 475°F
- Offset setting must be reduced by 25°F
- If offset is shown as 10°F, press the "0" pad until -15 is shown in the display (10 - 25 = -15)

Display Diagnostics

WARNING

To avoid risk of electrical shock, personal injury or death; disconnect power to oven and discharge capacitor before servicing, unless testing requires it.

CAUTION

All repairs as described in this troubleshooting section are to be performed only after the caution procedures one through eight listed below have been followed.

1. Check grounding before checking for possible causes.
2. Be careful of the high voltage circuit.
3. Discharge high voltage capacitor.
4. When checking the continuity of the switches or the high voltage transformer, disconnect one lead wire from these parts and then check continuity with the AC plug removed. To do otherwise may result in a false reading or damage to your meter.
5. Do not touch any parts of the circuitry on the P.C. Board circuit since static electric discharge may damage this control panel. Always touch yourself to ground while working on this panel to discharge any static charge in your body.
6. 208/230 VAC is present in the high voltage circuit board, power relay and primary circuit of low voltage transformer.
7. When troubleshooting, be cautious of possible electrical hazard.
8. When testing convection operation, convection fan may start at any time or if oven is hot.

Error Codes

During operation, the display may show the following service codes:

NOTE: Before scheduling service for any error codes, instruct customer to unplug oven for 1 minute, reconnect power, and retest. If unit operates properly, no service call is required.

Display	Description	Corrective Action
Err1	Failed H.V. Board	Replace H.V. board.
Err2	Failed H.V. Board Shorted Touch Panel Shorted Display Board Shorted Cable HV to Display Board	Replace H.V. board. Replace Touch Panel. Replace Display Board. Replace Cable.
Err3	Failed H.V. Board	Replace H.V. board.
Err4	Failed H.V. Board	Replace H.V. board.
Err5	Shorted Touch Panel	NOTE: If Touch Panel is pressed for more than 30 seconds, this error code will appear. <ol style="list-style-type: none"> 1. Disconnect oven from power supply. 2. Disconnect side touch panel connector from display board (J5). 3. Reconnect oven to power supply. 4. If "Err5" reappears after 30 seconds, replace top touch panel. 5. If "Err5" does not reappear after 30 seconds, replace side touch panel.
Err6	Failed H.V. Board	Replace H.V. board.
HOT		NOTE: If oven is being operated in convection or combination mode and power is temporarily interrupted (unit unplugged or power outage), the oven control cut-out will open and cause "HOT" to be displayed. When power is reconnected, the blower will begin to operate. The control cut-out will reset when sufficiently cooled, causing "HOT" to disappear. <ul style="list-style-type: none"> • Open TCO (magnetron). • Blower motor inoperative. • Restricted air filter. • High ambient temperature. • Oven operated empty or with light loads. • Broken or loose wire. • H.V. board inoperative.
Door	Door Interlock Primary Switch	<ul style="list-style-type: none"> • Verify latch mechanism moves freely on door. • Verify J1 connector on display board is properly seated. • Test interlock switch assembly and perform door adjustment if necessary. • Replace interlock switch assembly.

Wiring Diagram and Schematic



WARNING

To avoid risk of electrical shock, personal injury or death; disconnect power to oven and discharge capacitor before servicing, unless testing requires it.

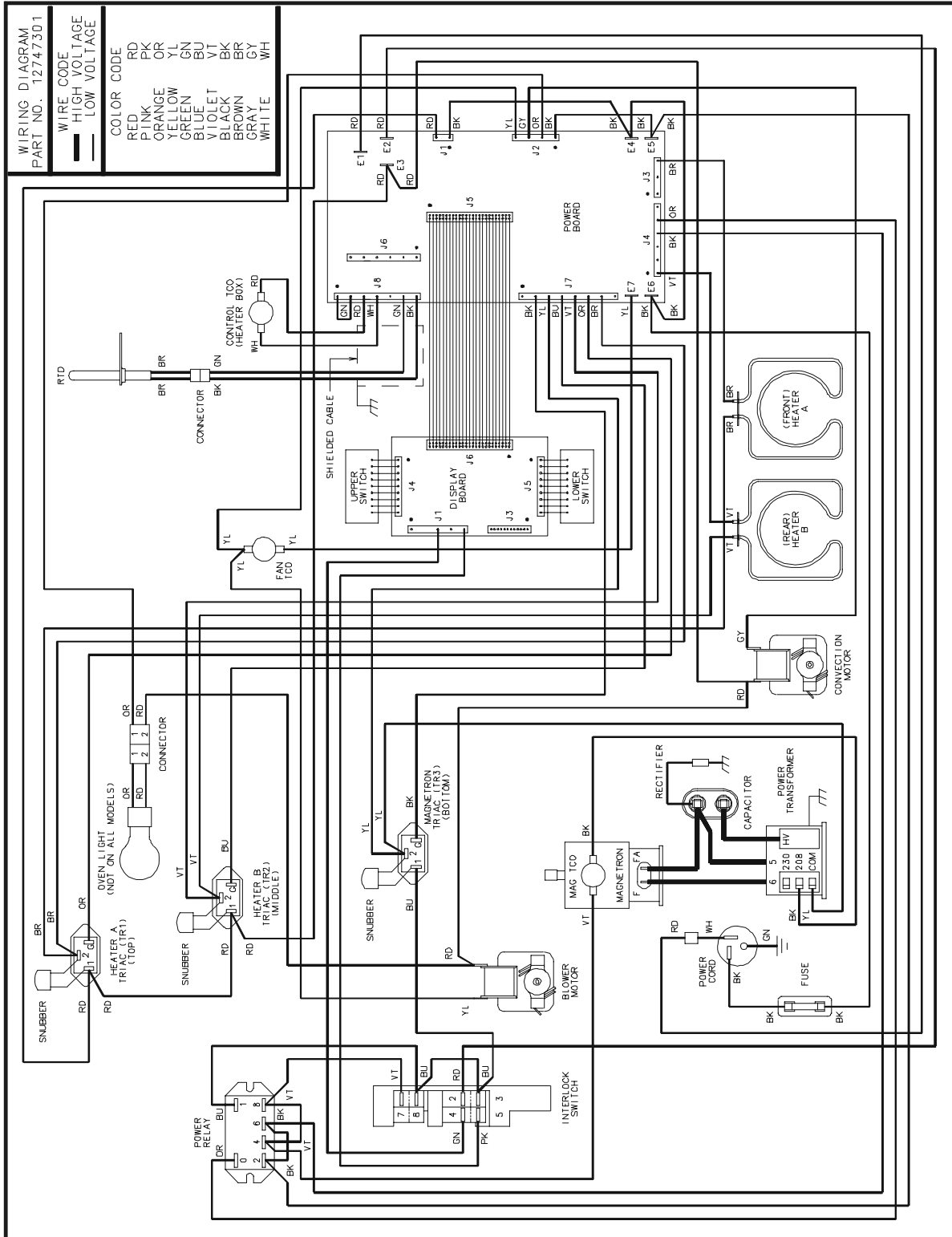

12747301

Wiring Diagram and Schematic



WARNING

To avoid risk of electrical shock, personal injury or death; disconnect power to oven and discharge capacitor before servicing, unless testing requires it.

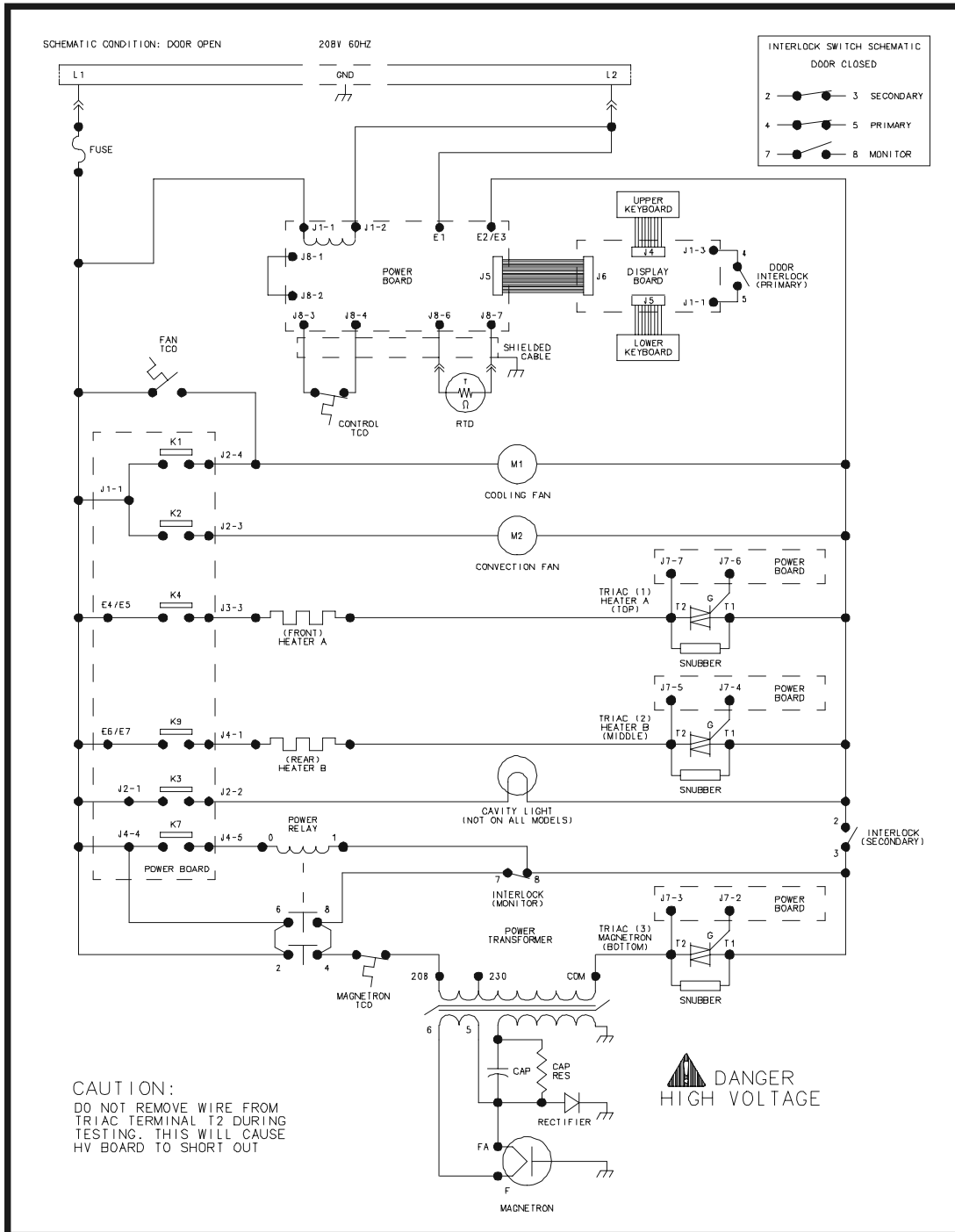

12747301

