

Service

This manual is to be used by qualified appliance technicians only. Maytag does not assume any responsibility for property damage or personal injury for improper service procedures done by an unqualified person.

This service manual replaces 16022123.

Countertop Commercial Microwave Ovens

This manual covers technical service information.

This manual includes, but is not limited to the following:

LD10D2	P1329702M
LD10MP	P1329703M
LD10MPS	P1329708M

Important Information

Important Notices for Servicers and Consumers

Maytag will not be responsible for personal injury or property damage from improper service procedures. Pride and workmanship go into every product to provide our customers with quality products. It is possible, however, that during its lifetime a product may require service. Products should be serviced only by a qualified service technician who is familiar with the safety procedures required in the repair and who is equipped with the proper tools, parts, testing instruments and the appropriate service information. **IT IS THE TECHNICIANS RESPONSIBILITY TO REVIEW ALL APPROPRIATE SERVICE INFORMATION BEFORE BEGINNING REPAIRS.**



WARNING

To avoid risk of severe personal injury or death, disconnect power before working/servicing on appliance to avoid electrical shock.

To locate an authorized servicer, please consult your telephone book or the dealer from whom you purchased this product. For further assistance, please contact:

Commercial Support Center

CAIR Center

Web Site

WWW.AMANACOMMERCIAL.COM

Telephone Number

1-866-426-2621

Recognize Safety Symbols, Words, and Labels



DANGER

DANGER—Immediate hazards which **WILL** result in severe personal injury or death.



WARNING

WARNING—Hazards or unsafe practices which **COULD** result in severe personal injury or death.



CAUTION

CAUTION—Hazards or unsafe practices which **COULD** result in minor personal injury, product or property damage.

Table of Contents

Important Information	2	Disassembly Procedures	
Important Safety Information	4-8	Disconnecting Wire Terminals	20
General Information		Outer Case	20
Unpacking Equipment	9	Door Assembly	20
Placement of the Oven	9	Door Disassembly	21
Radio Interference	9	Control Panel	21
Model Identification	9	Controller Removal (Electronic Models)	22
Service	9	Key Pad Removal	22
Parts and Accessories	10	Timer Removal (Dial Models)	22
Extended Service Plan	10	Interlock Switches	23
Microwave Oven Features	10	High Voltage Capacitor	23
Microwave Specifications	10	Diode	24
Troubleshooting Procedures	11-15	Transformer	24
Component Testing Procedures	16	Fuse Block / Filter Assembly	24
Microwave Power Test Procedures		Fuse	24
Power Test (Traditional 1 Liter Test)	18	Magnetron	24
Microwave Leakage Testing		Fan Motor	24
Equipment	19	Cavity Thermostat	25
Procedure For Measuring Radiation Leakage	19	Light Socket / Bulb Assembly	25
Measurement With the Outer Panel Removed	19	Antenna	25
Measurement With a Fully Assembled Oven	19	Stirrer Motor	25
Record Keeping and Notification After Measurement	19	Wiring Diagrams And Schematics	26
		Appendix A	
		Operation—LD10	A-2
		Cooking Guidelines	A-7
		Care and Cleaning	A-9
		Before Calling for Service	A-10
		Appendix B	
		Operation—LD10D	B-2
		Cooking Guidelines	B-3
		Care and Cleaning	B-5
		Before Calling for Service	B-6

Important Safety Information

WARNING

Read the following information to avoid possible exposure to microwave radiation:

The basic design of the Amana Microwave Oven makes it an inherently safe device to both use and service. However, there are some precautions which should be followed when servicing the Radarange to maintain this safety. These are as follows:

1. Always operate the unit from an adequately grounded outlet. Do not operate on a two-wire extension cord.
2. Before servicing the unit (if unit is operable) perform the microwave leakage test.
3. The oven should never be operated if the door does not fit properly against the seal, the hinges or hinge bearings are damaged or broken; the choke is damaged, (pieces missing, etc.); or any other visible damage can be noted. Check the choke area to ensure that this area is clean and free of all foreign matter.
4. If the oven operates with the door open and produces microwave energy, take the following steps:
 - A. Tell the user not to operate the oven.
 - B. Contact Maytag Amana Manufacturing immediately.
5. Always have the oven disconnected when the outer case is removed except when making the "live" tests called for in the Service Manual. Do not reach into the equipment area while the unit is energized. Make all connections for the test and check them for tightness before plugging the cord into the outlet.
6. Always ground the capacitors on the magnetron filter box with an insulated-handle screwdriver before working in the high voltage area of the equipment compartment. Some types of failures will leave a charge in these capacitors and the discharge could cause a reflex action which could make you injure yourself.
7. Always remember that in the area of the transformer there is HIGH VOLTAGE. When the unit is operating keep this area clear and free of anything which could possibly cause an arc or ground, etc.
8. Do not for any reason defeat the interlock switches there is not valid reason for this action at any time; nor will it be condoned by Amana.
9. **IMPORTANT:** Before returning a unit to a customer, be sure to check for proper switch interlock action.
10. The Amana Microwave Oven should never be operated with any components removed and/or bypassed or when any of the safety interlocks are found to be defective, or when any of the seal surfaces are defective, missing, or damaged.
11. All Amana microwave ovens meet all requirements of the radiation control for Health and Safety Act of 1968. Due to measurement uncertainties, the maximum leakage for the field will be $4\text{mw}/\text{cm}^2$.
12. To ensure that the unit does not emit excessive microwave leakage and to meet the Department of Health and Human Services guidelines, check the oven for microwave leakage using the models Narda 8110B, Holaday HI-1501, HI-1510, or HI-1710 leakage monitor as outlined in the instruction. The maximum leakage level allowed when following those instructions is $4\text{mw}/\text{cm}^2$.
13. If servicer encounters an emission reading over $4\text{mw}/\text{cm}^2$, the servicer is to cease repair and contact the Maytag Service Department immediately for further direction. Maytag Manufacturing will contact the proper Government Agency upon verification of the test results.

Important Safety Information



Recognize this symbol as a SAFETY message



WARNING

When using electrical equipment, basic safety precautions should be followed to reduce the risk of burns, electrical shock, fire, or injury to persons.

1. **READ** all instructions before using equipment.
2. **READ AND FOLLOW** the specific “**PRECAUTIONS TO AVOID POSSIBLE EXPOSURE TO EXCESSIVE MICROWAVE ENERGY**”.
3. This equipment **MUST BE GROUNDED**. Connect only to properly GROUNDED outlet. See “**GROUNDED INSTRUCTIONS**”.
4. Install or locate this equipment **ONLY** in accordance with the installation instructions in this manual.
5. Some products such as whole eggs and sealed containers, for example, closed glass jars may explode and **SHOULD NOT** be **HEATED** in this oven.
6. Use this equipment **ONLY** for its intended use as described in this manual. Do not use corrosive chemicals or vapors in this equipment. This type of oven is specifically designed to heat or cook. It is not designed for industrial or laboratory use.
7. As with any equipment, **CLOSE SUPERVISION** is necessary when used by **CHILDREN**.
8. **DO NOT** operate this equipment if it has a damaged cord or plug, if it is not working properly, or if it has been damaged or dropped.
9. This equipment, including power cord, must be serviced **ONLY** by qualified service personnel. Special tools are required to service equipment. Contact nearest authorized service facility for examination, repair, or adjustment.
10. **DO NOT** cover or block filter or other openings on equipment.
11. **DO NOT** store this equipment outdoors. **DO NOT** use this product near water, for example, near a kitchen sink, in a wet basement, or near a swimming pool, and the like.
12. **DO NOT** immerse cord or plug in water.
13. Keep cord **AWAY** from **HEATED** surfaces.
14. **DO NOT** let cord hang over edge of table or counter.
15. See door cleaning instructions in “Care and Cleaning” section.
16. **For commercial use only.**



CAUTION

To reduce risk of fire in the oven cavity:

- a. **DO NOT** overcook food. Carefully attend equipment if paper, plastic, or other combustible materials are placed inside the oven to facilitate cooking.
- b. Remove wire twist-ties from paper or plastic bags before placing bag in oven.
- c. **KEEP** oven **DOOR CLOSED**, turn oven off, and disconnect the power cord, or shut off power at the fuse or circuit breaker panel, if materials inside the oven should ignite. Fire may spread if door is opened.
- d. **DO NOT** use the cavity for storage. **DO NOT** leave paper products, cooking utensils, or food in oven.

SAVE THESE INSTRUCTIONS

Important Safety Information



CAUTION

To avoid risk of personal injury or property damage, observe the following:

1. Briskly stir or pour liquids before heating with microwave energy to prevent spontaneous boiling or eruption. Do not overheat. If air is not mixed into a liquid, liquid can erupt in oven or after removal from oven.
2. Do not deep fat fry in oven. Fat could overheat and be hazardous to handle.
3. Do not cook or reheat eggs in shell or with an unbroken yolk using microwave energy. Pressure may build up and erupt. Pierce yolk with fork or knife before cooking.
4. Pierce skin of potatoes, tomatoes, and similar foods before cooking with microwave energy. When skin is pierced, steam escapes evenly.
5. Do not operate equipment without load or food in oven cavity.
6. Use only popcorn in packages designed and labeled for microwave use. Popping time varies depending on oven wattage. Do not continue to heat after popping has stopped. Popcorn will scorch or burn. Do not leave oven unattended.
7. Do not use regular cooking thermometers in oven. Most cooking thermometers contain mercury and may cause an electrical arc, malfunction, or damage to oven.
8. Do not heat baby bottles in oven.
9. Do not use metal utensils in oven.
10. Never use paper, plastic, or other combustible materials that are not intended for cooking.
11. When cooking with paper, plastic, or other combustible materials, follow manufacturer's recommendations on product use.
12. Do not use paper towels which contain nylon or other synthetic fibers. Heated synthetics could melt and cause paper to ignite.
13. Do not heat sealed containers or plastic bags in oven. Food or liquid could expand quickly and cause container or bag to break. Pierce or open container or bag before heating.
14. To avoid pacemaker malfunction, consult physician or pacemaker manufacturer about effects of microwave energy on pacemaker.

PRECAUTIONS TO AVOID POSSIBLE EXPOSURE TO EXCESSIVE MICROWAVE ENERGY

- a. **DO NOT** attempt to operate this oven with the door open since open-door operation can result in harmful exposure to microwave energy. It is important not to defeat or tamper with the safety interlocks.
- b. **DO NOT** place any object between the oven front face and the door or allow soil or cleaner residue to accumulate on sealing surfaces.
- c. **DO NOT** operate the oven if it is damaged. It is particularly important that the oven door close properly and that there is no damage to the: (1) door (bent), (2) hinges and latches (broken or loosened), (3) door seals and sealing surfaces.
- d. The oven should **NOT** be adjusted or repaired by anyone except properly qualified service personnel.

SAVE THESE INSTRUCTIONS

Important Safety Information

WARNING

Precautions to be observed before and during servicing to avoid possible exposure to excessive microwave energy, or electrical shock disconnect power to oven.

- Do not operate or allow oven to be operated with door open.
- Make the following safety checks on all ovens to be serviced before activating the magnetron or other microwave source, and make repairs as necessary:
 - Interlock operation
 - Proper door closing
 - Seal and sealing surfaces (arcing, wear, and other damage)
 - Damage to or loosening of hinges and latches
 - Evidence of dropping or abuse
- Before turning on microwave power for any service test or inspection within the microwave generating compartments, check the magnetron, waveguide or transmission line, and cavity for proper alignment, integrity, and connections.
- Any failed or misadjusted components in the interlock, monitor, door seal, and microwave generation and transmission systems shall be repaired, replaced or adjusted by procedures described in this manual before oven is released to the consumer.
- Check microwave leakage to verify compliance with the federal performance standard should be performed on each oven prior to release to the consumer.

WARNING

To avoid risk of electrical shock, injury or death; make sure these grounding instructions are followed.

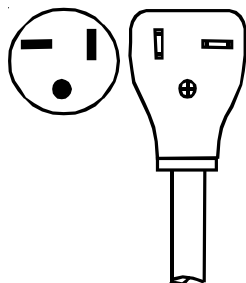

NEMA 5-20R/5-20P
120V-20AMP

WARNING

Do not remove grounding prong when installing grounded appliance in a home or business that does not have three wire grounding receptacle, under no condition is grounding prong to be cut off or removed. It is the personal responsibility of the consumer to contact a qualified electrician and have properly grounded three prong wall receptacle installed in accordance with appropriate electrical codes.

WARNING

To avoid the risk of electrical shock or death, do not alter the plug.

WARNING

To avoid the risk of electrical shock or death, this equipment must be grounded.

This equipment **MUST** be grounded. In the event of an electrical short circuit, grounding reduces the risk of electric shock by providing an escape wire for the electric current. This oven is equipped with a cord having a grounding wire with a grounding plug. The plug must be plugged into an outlet that is properly installed and grounded.

Consult a qualified electrician or servicer if grounding instructions are not completely understood, or if doubt exists as to whether the equipment is properly grounded.

Do not use an extension cord. If the product power cord is too short, have a qualified electrician install a three-slot receptacle. This oven should be plugged into a separate 60 hertz circuit with the electrical rating as shown in the appropriate drawing. Models operate with a 120 supply voltage. When a microwave oven is on a circuit with other equipment, an increase in cooking times may be required and fuses can be blown.

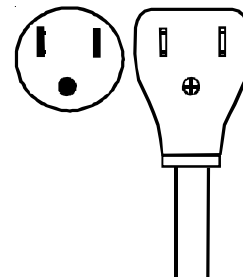

NEMA 5-15R/5-15P
120V-15AMP

Important Safety Information

Servicing of Grounded Products

The standard accepted color coding for grounding wires is GREEN or GREEN WITH YELLOW STRIPE. These ground leads are NOT to be used as current carrying conductors. It is extremely important that the technician replace any and all grounds prior to completion of the service call. Under no condition should ground wire be left off causing a potential hazard to technicians and consumer.

Wiring

A good service practice is never route wiring over terminals and/ or sharp edges. This applies to any wiring without regard to the circuit voltage. Wire installation material and thickness is designed and regulated for electrical spacing purpose only, but cannot always be relied upon because of possible cuts and/or abrasions, which can occur during servicing.



WARNING

To avoid risk of electrical shock, personal injury or death; verify the oven is properly grounded and polarized.

Proper Grounding and Polarization of 120 Volts Wall Outlets

For the safety of our customers and the service technician ALL appliances have a three-prong power cord and MUST be connected to a properly polarized and grounded wall outlet.

This information was written for those who do not understand grounding and polarization of a wall outlet.

A 120 volt wall outlet must always be wired as shown below.

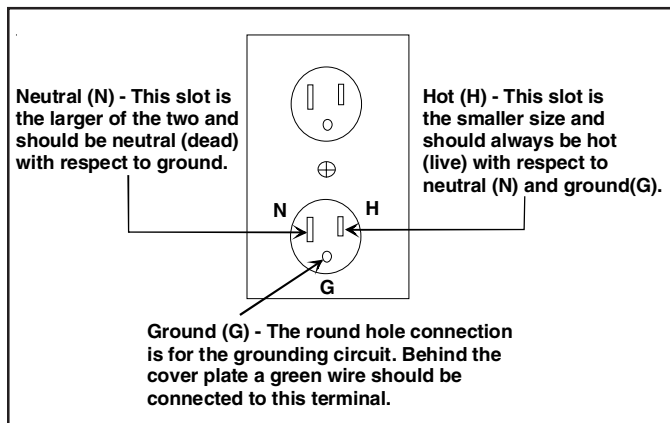

Explanation

Polarization—This means that the larger slot must be neutral and the small slot must be hot (live).

Mispolarized—The outlet is miswired so that the larger slot is hot (live) and the smaller slot is neutral.

Grounded—This means the round hole connection is connected to earth ground through a connection to the main power panel.

Ungrounded—The round hole connection is not complete to earth ground and/or the main power panel.

Test Procedures (2 Methods)

Method #1

Purchase and use a ground monitor which indicates a correctly or incorrectly wired outlet by instructions imprinted on the monitor body.

Method #2

Voltmeter - (Use scale over 125 Volts A.C.)

- Test A - "H" to "N" must indicate line voltage.
- Test B - "H" to "G" must indicate line voltage.
- Test C - "N" to "G" must indicate zero (0) volts.

If "N" to "G" indicates line voltage the outlet is improperly polarized.

If "H" to "G" indicates zero (0) volts the outlet is not grounded.

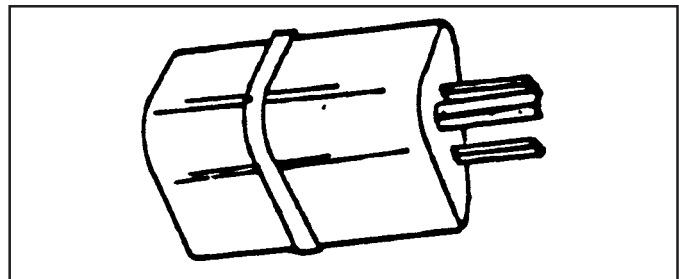

CAUTION

To avoid risk of electrical shock, personal injury or property damage; wiring changes or grounding of wall outlet are to be made only by a qualified electrician.

General Test Information

Most testing in the manual is conducted with an ohmmeter using a multiplier scale of X 10k (k—thousand ohms). When using this scale, it is important that your fingers do not touch the metal parts of the test probes. To do so will give a false indication of the ohm reading.

General Information

Unpacking Equipment

- Inspect equipment for damage such as dents in door or dents inside oven cavity.
- Report any dents or breakage to source of purchase immediately. Do not attempt to use oven if damaged.
- Remove all materials from oven interior.

Placement of the Oven

- Do not install microwave next to or above source of heat, such as pizza oven or deep fat fryer. This could cause the microwave to operate improperly and could shorten the life of electrical components.
- Install microwave on a level countertop surface.
- Do not block or obstruct air filter. Allow access for cleaning.
- All air vents must be kept clear during cooking. If air vents are covered during operation the oven may overheat. In this case, a sensitive thermal safety device automatically turns the oven off. The oven will be inoperable until the oven has cooled sufficiently.

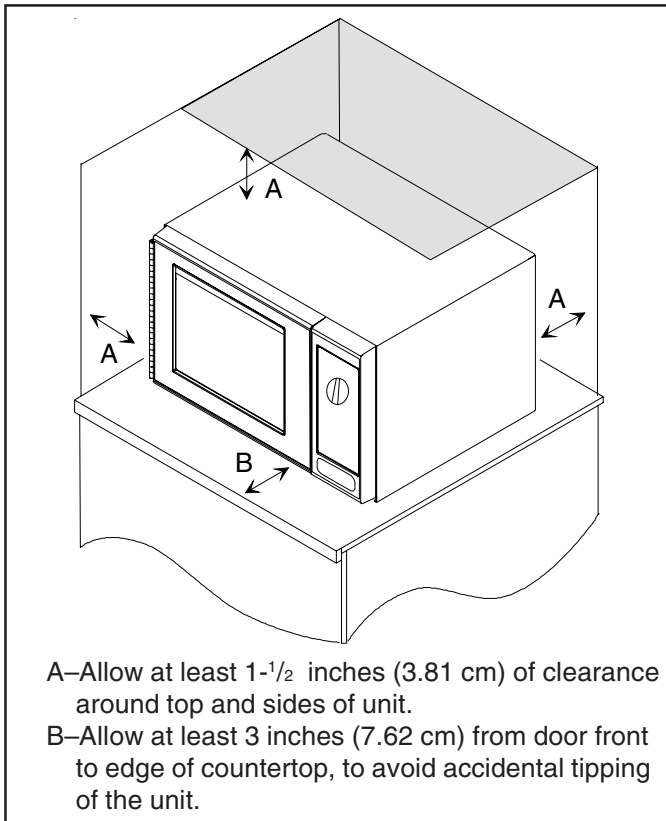

Radio Interference

Microwave oven operation may cause interference to radio, television, or similar equipment. Reduce or eliminate interference by doing the following:

- Clean the door and sealing surfaces of microwave oven according to instructions in “Care and Cleaning” section.
- Place radio, television, ect. as far as possible from the microwave oven.
- Use a properly installed antenna on radio, television, ect. to obtain stronger signal reception.

Model Identification

Complete registration card and promptly return. If registration card is missing:

- For Amana product call 1-866-426-2621 or visit the Web Site at www.amanacommercial.com
- For product in Canada call 1-866-426-2621 or visit the Web Sites at www.amanacommercial.com

When contacting provide product information located on rating plate. Record the following:

Model Number: _____
Manufacturing Number: _____
Serial or S/N Number: _____
Date of purchase: _____
Dealer’s name and address: _____

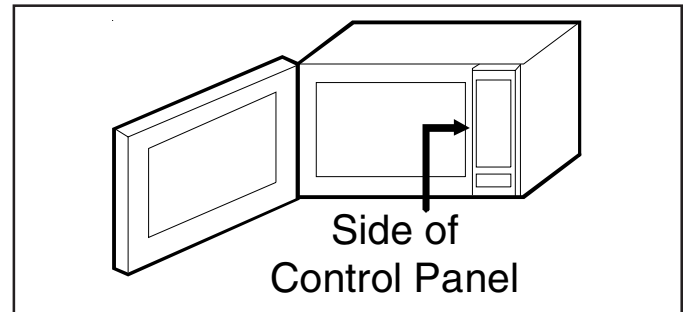

Service

Keep a copy of sales receipt for future reference or in case warranty service is required. To locate an authorized servicer:

- For Amana product call 1-866-426-2621 or visit the Web Site at www.amanacommercial.com
- For product in Canada call 1-866-426-2621 or visit the Web Sites at www.amanacommercial.com

Warranty service must be performed by an authorized servicer. We also recommend contacting an authorized servicer, if service is required after warranty expires.

General Information

Microwave Oven Features

- A—Window door screen
- B—Spatter shields
- C—Control panel (Electric or Dial)
- D—Door open button
- E—Safety door lock system

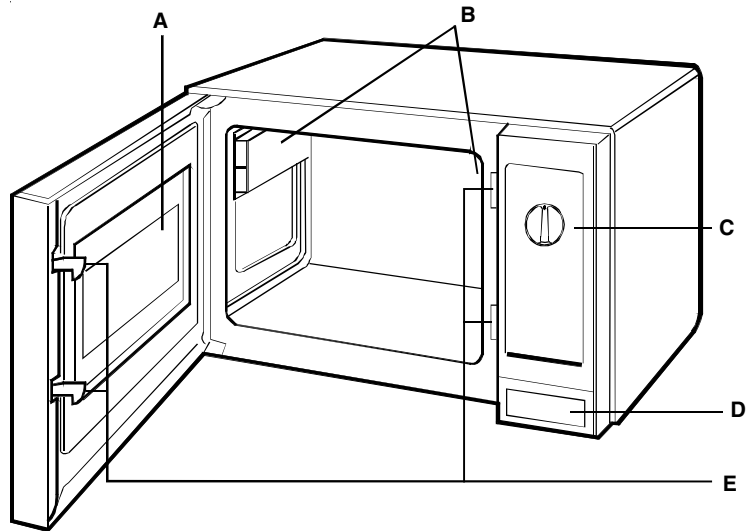

Microwave Specifications

Models	LD10D2 LD10MP LD10MPS
Power Source	
Voltage AC	120 VAC
Amperage (Single Unit)	15 A
Frequency	60 Hz
Single phase, 3-wire ground	Yes
Receptacle	5-15 R
Plug	5-15 P
Power cord	5 ft. (1.5 m)
Power Output	
Normal microwave energy (IEC705)	1000 Watts
Operating Frequency	2450 MHz
Power Consumption	
Cook condition microwave	1450 Watts
Cabinet	
Width	20 9/16 in (53.0 cm)
Height	12 3/8 in (31.5 cm)
Depth	15 1/2 in (39.4 cm)
Oven Interior	
Width	13 7/8 in (34.4 cm)
Height	9 5/32 in (23.3 cm)
Depth	14 3/8 in (36.5 cm)
Capacity	1.0 cu.ft. (28.3 l)
Weight	
Crated	40 lbs (18 kg)

Troubleshooting Procedures

When you get a complaint from customers, evaluate the complaint carefully. If the following symptoms apply, instruct the customer in the proper use of the microwave oven. This can eliminate an unnecessary service call.



CAUTION

- Verify proper grounding before checking for trouble.
- Be careful of the high voltage circuit.
- Discharge the high voltage capacitor.
- When checking the continuity of the switches or of the high voltage transformer, disconnect one lead wire from these parts and then check continuity with the AC plug removed. To do otherwise may result in a false reading or damage to your meter.
- Do not touch any part of the circuit on the controller, since static electric discharge may damage the control panel. Always touch yourself to ground while working on this panel to discharge any static charge built up in your body.

Condition	Cause	Remedy
Microwave oven does not work.	<ul style="list-style-type: none"> • Inserting multiple plugs into one outlet and using them at the same time (blown fuse or breaker). • Microwave oven plug is not inserted tightly. 	<ul style="list-style-type: none"> • Avoid using other electrical appliances when you use the microwave oven. • Insert microwave oven plug securely.
Output power is too low.	<ul style="list-style-type: none"> • Low AC input voltage. • Food temperature is too low. 	<ul style="list-style-type: none"> • Use the microwave oven at adequate line voltage. • This may not be a defect. It is possible that the food should be cooked for a longer time period.
Sparks occur.	<ul style="list-style-type: none"> • Using metallic ware and allowing it to touch the oven wall. • Ceramic ware trimmed in gold or silver is used. 	<ul style="list-style-type: none"> • Do not use metallic ware for cooking. • Do not use any type of cookware with metallic trimming.
Uneven cooking.	Inconsistent food thickness, inconsistent fat or moisture distribution within the food products.	<ul style="list-style-type: none"> • Use plastic wrap or lid. • Stir once or twice while cooking soup, cocoa, milk, etc.

Troubleshooting Procedures (Electronic Models)

Trouble 1: The following visual conditions indicate a probable failed control circuit.

1. Incomplete segments.
 - Segment missing.
 - Partial segment missing.
 - Digit flickering (Note: Slight flickering is normal.)
2. Colon does not turn on or blink.
3. A distinct change in the brightness of one or more numbers in display.
4. One or more digits in the display are not lighting.
5. Display indicates a number different from one touched, for example, key in 5 and 3 appears in the display.
6. Specific numbers (for example 7 or 9) will not display when key pad is touched.
7. Display does not count down with time blinking or count up during operation.
8. Display obviously jumps in time while counting down.
9. Display counts down too fast while cooking.
10. Each indicator light does not turn on after setting cooking cycle.
11. Display time of day does not reappear when cooking is finished.

Condition	Check	Result	Cause	Remedy
No input can be programmed.	Check the connection between keypad and controller.	<ul style="list-style-type: none"> • Continuity • No continuity 	<ul style="list-style-type: none"> • Failed controller. • Loose connection. 	<ul style="list-style-type: none"> • Replace controller. • Repair connection.
<ol style="list-style-type: none"> 1. Some inputs cannot be programmed. 2. Display shows a number or figure different from one touched. 3. Random programming when touching other pads. 4. Display is fixed at some figure and can not accept any input. 	Replace keypad and check operation.	<ul style="list-style-type: none"> • Everything works as specified. • Still have trouble. 	<ul style="list-style-type: none"> • Failed keypad. • Failed controller. 	<ul style="list-style-type: none"> • Replace keypad. • Replace controller.

Troubleshooting Procedures (Dial and Electronic Models)

Oven does not operate at all, display window does not display any digits and no input is accepted.

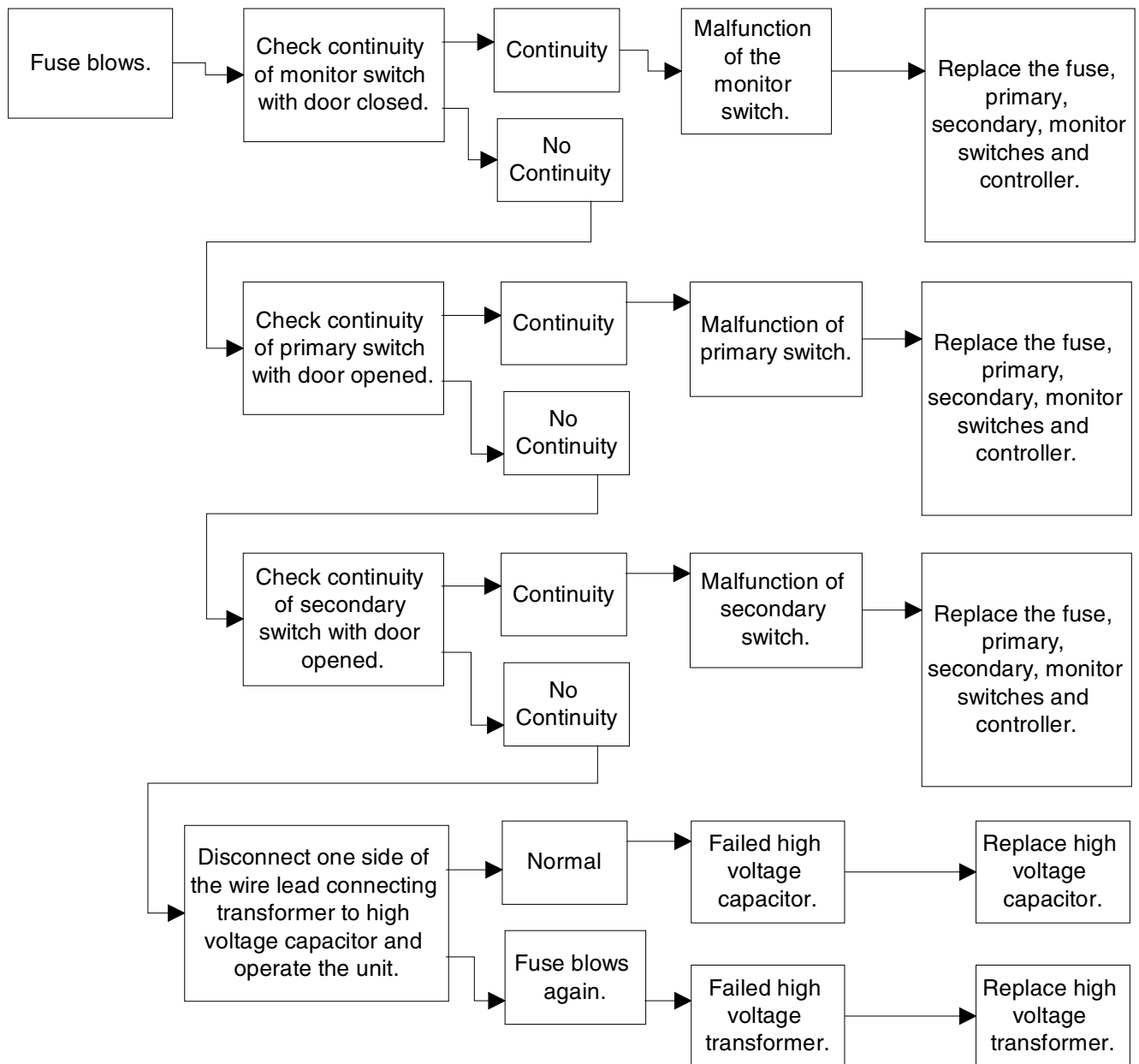

NOTE: If replacing a switch, all switches must be replaced at the same time.

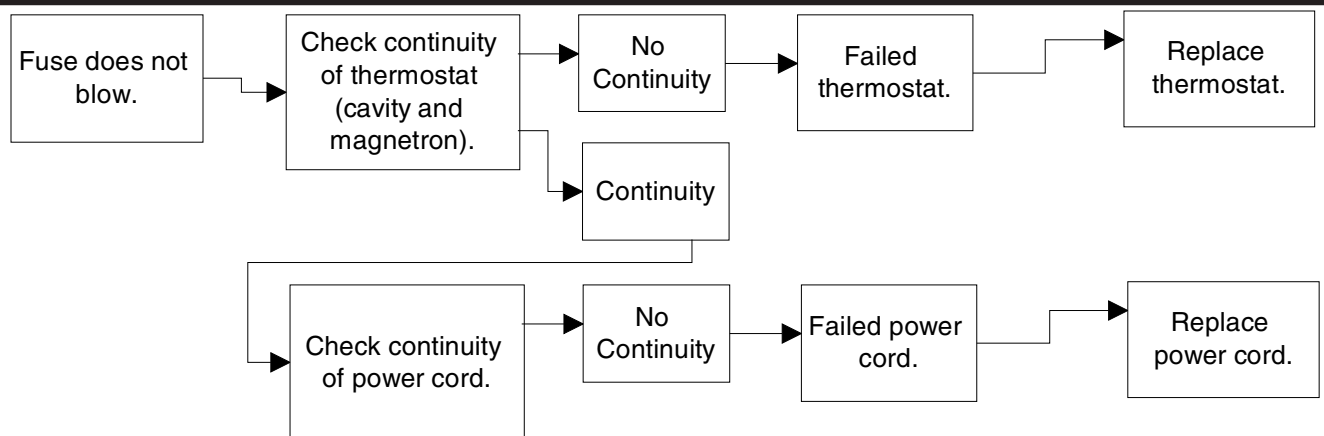

Troubleshooting Procedures (Electronic Models)

Display shows all digits programmed, but does not start cooking when the START pad is pressed.

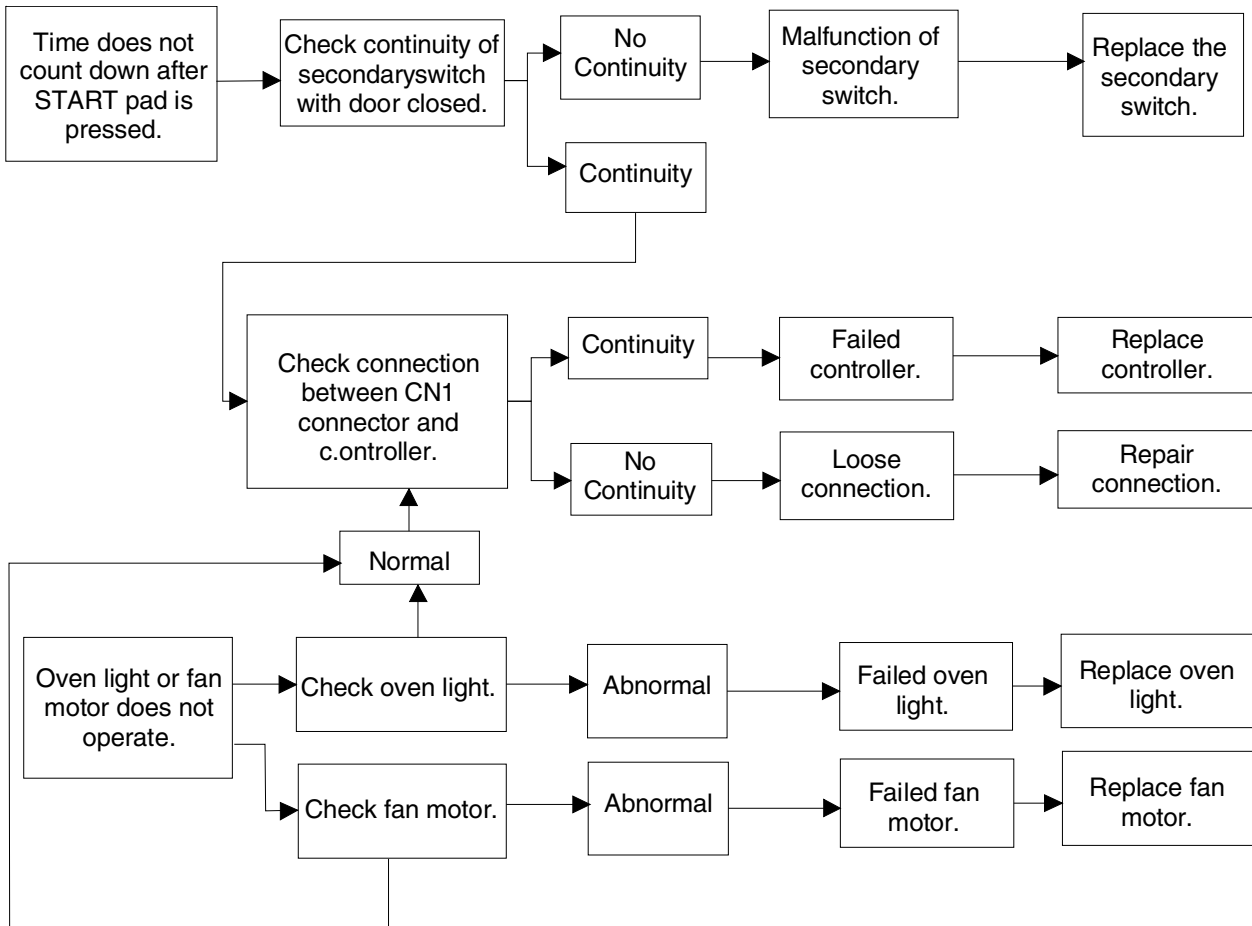

Dial and Electronic Models

Oven operates with little or no heat.

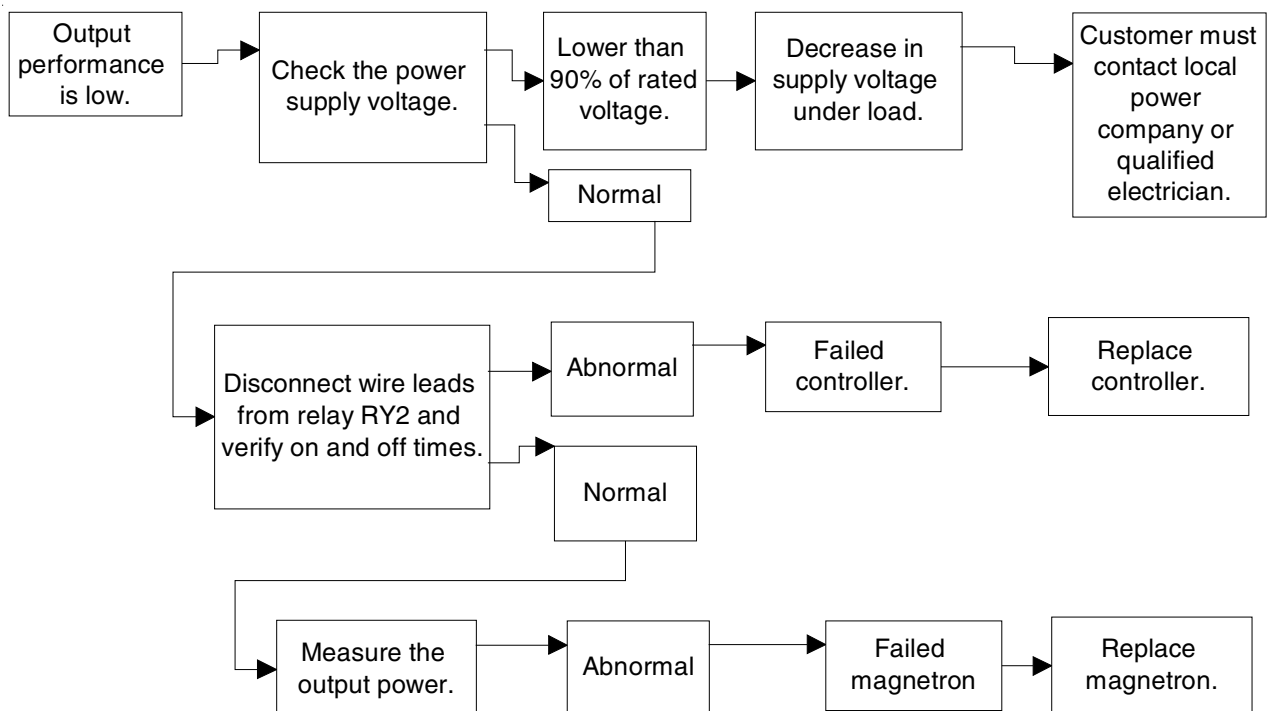

Troubleshooting Procedures (Dial and Electronic Models)

No microwave oscillation even when oven light and fan motor operate.

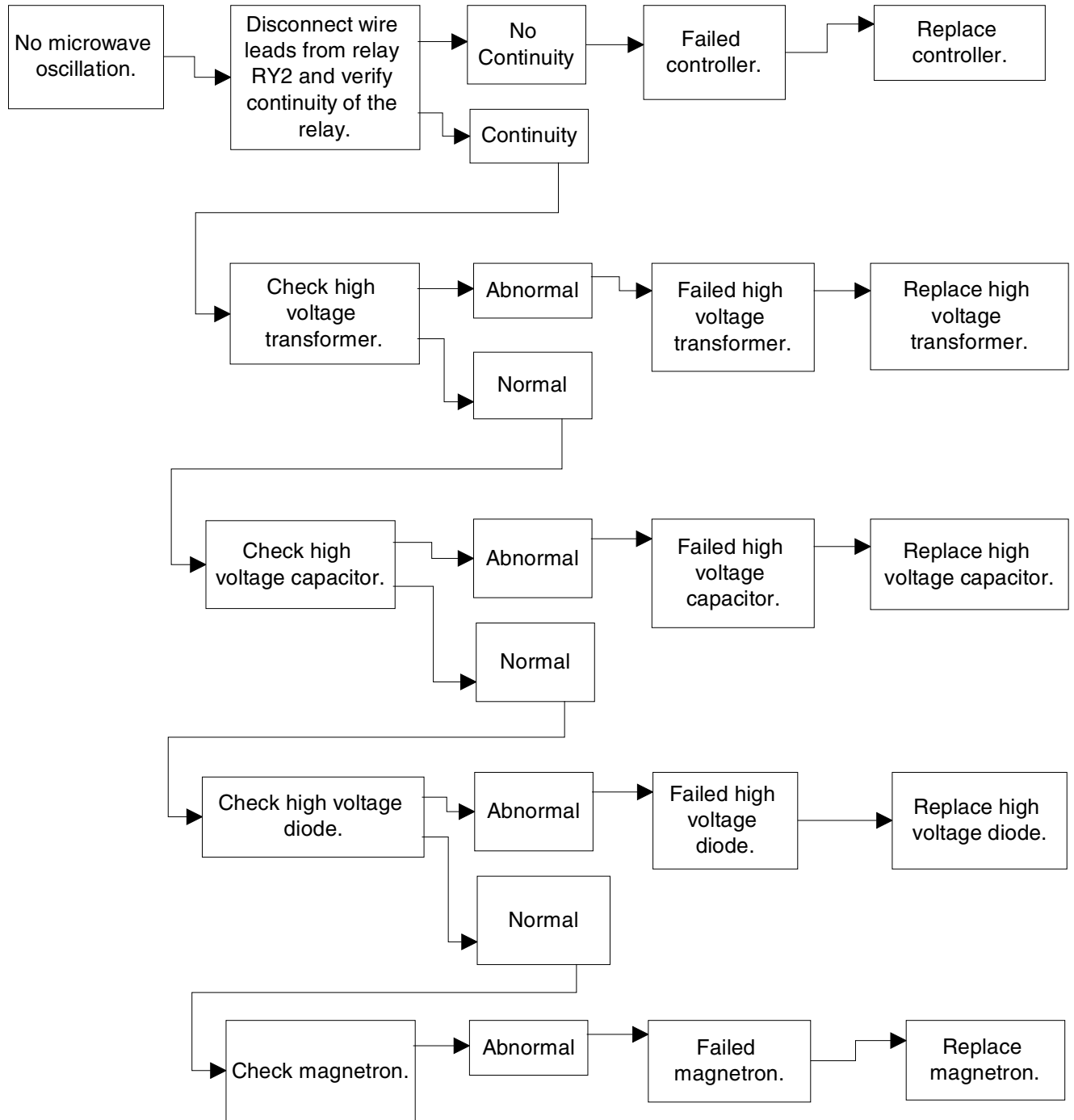

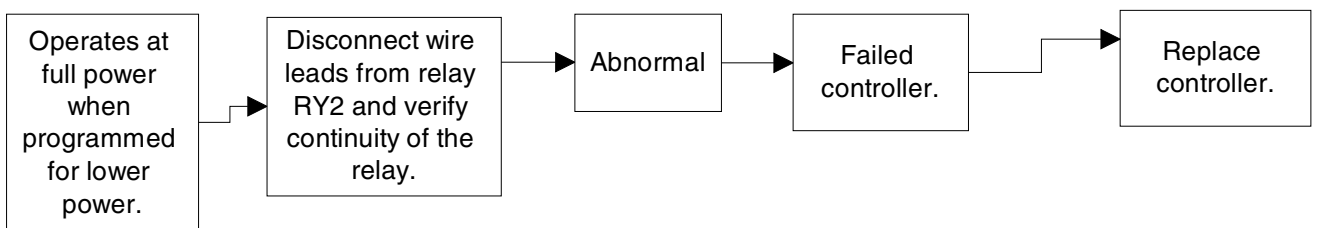

Electronic Model Only



Component Testing Procedures

⚠ WARNING

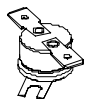
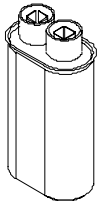
To avoid risk of electrical shock, personal injury or death, disconnect power to oven and discharge capacitor before servicing, unless testing requires it.

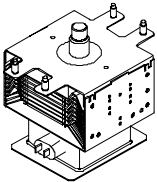
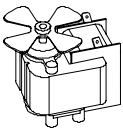
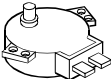
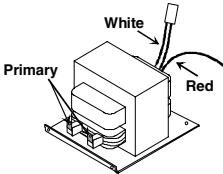
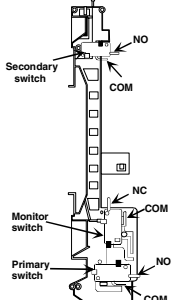
Illustration	Component	Test	Results
	Thermal Cutout	Disconnect all wires from TCO. Measure resistance across terminals. Magnetron TCO Cavity TCO.....	Open at 293°F (145°C) and closed at 185°F (85°C) Opens at 194°F (90°C)
	Capacitor	Discharge Capacitors Remove wires from capacitor terminals and connect ohmmeter, set on highest resistance scale to terminals. Also check between each terminal and capacitor case.	Between Terminals: Meter should momentarily deflect towards zero then return to over 5 MΩ. IF no deflection occurs, or if continuous deflection occurs, replace capacitor. Terminal to Case: Infinite resistance
	Diode Assembly	Discharge Capacitors Remove diode lead from capacitor and connect ohmmeter. Reverse leads for second test.	Infinite resistance should be measured in one direction and 50KΩ or more in the opposite direction. NOTE: Analog meter must contain a battery of 6 volts minimum.
	Magnetron	Discharge Capacitors Remove wires from magnetron and connect ohmmeter to terminals. Also check between each terminal and ground.	Between Terminals: Less than 1 Ω Each terminal to ground measures Infinite resistance. Note: This test is not conclusive. If oven does not heat and all other components test good replace the magnetron and re-test.
	Fan Motor	Remove all wires from motor. Measure resistance across coil	Approximately 50 - 150 Ω
	Stirrer motor	Remove all wires from motor. Measure resistance across coil	Approximately 2 – 4K Ω
	Transformer	Discharge Capacitors Remove all wires from terminals. Measure resistance from: Primary Filament (white leads)..... Secondary (red lead) to transformer base plate.....	<1 Ω <1 Ω Approximately 60 -90 Ω
	Interlock switches	Disconnect wires to switch With door open measure resistance from: COM to N.O.—Secondary COM to N.C.—Monitor COM to N.O.—Primary..... With door closed measure resistance from: COM to N.O.—Secondary COM to N.C.—Monitor COM to N.O.—Primary.....	Infinite Ω 0 Ω Infinite Ω 0 Ω Infinite Ω 0 Ω

Component Testing Procedures

⚠ WARNING

To avoid risk of electrical shock, personal injury or death, disconnect power to oven and discharge capacitor before servicing, unless testing requires it.

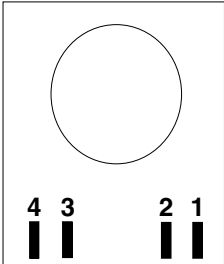
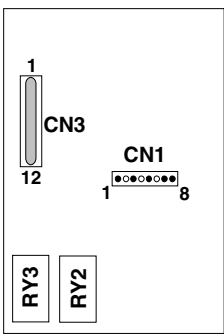
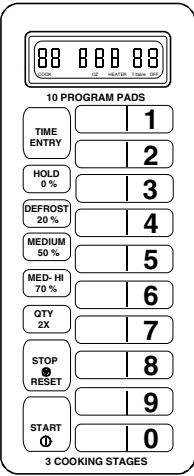
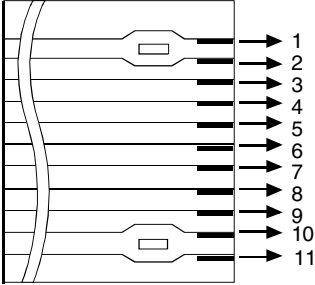
Illustration	Component	Test	Results																																																						
	Timer 6 minute	Disconnect wire from terminals. Measure resistance of the following terminals: Terminal 3 to terminal 4 (timer motor) Terminal 1 to terminal 2(timer switch)	Approximately 11 K Ω Timer OFF— infinite Ω Timer ON— < 1 Ω																																																						
	Control	<p>CN1 Pin 1 (black) to Pin 3 (white)</p> <p>RY2 (Cook Relay) Unplug oven and remove wire leads from RY2 terminals. Connect ohm-meter leads to terminals. Plug oven into power supply..... Initiate cook cycle..... NOTE: RY2 should cycle when using reduced power levels.</p> <p>RY3 (Fan Relay) Unplug oven and remove wire leads from RY3 terminals. Connect ohm-meter leads to terminals. Plug oven into power supply..... Initiate cook cycle..... NOTE: Fan relay remains energized for 60 seconds following cook cycle.</p>	Line voltage input to control transformer. Infinite Ω < 1 Ω <p style="text-align: center;">Power levels for Relay 2</p> <table border="1" style="width: 100%; border-collapse: collapse;"> <thead> <tr> <th>Power Level</th> <th>Cycles On for:</th> <th>Cycles Off for:</th> </tr> </thead> <tbody> <tr> <td>20%</td> <td>3 sec</td> <td>9 sec</td> </tr> <tr> <td>50%</td> <td>6 sec</td> <td>6 sec</td> </tr> <tr> <td>70%</td> <td>9 sec</td> <td>3 sec</td> </tr> <tr> <td>100%</td> <td>12 sec</td> <td>0 sec</td> </tr> </tbody> </table> Infinite Ω < 1 Ω	Power Level	Cycles On for:	Cycles Off for:	20%	3 sec	9 sec	50%	6 sec	6 sec	70%	9 sec	3 sec	100%	12 sec	0 sec																																							
Power Level	Cycles On for:	Cycles Off for:																																																							
20%	3 sec	9 sec																																																							
50%	6 sec	6 sec																																																							
70%	9 sec	3 sec																																																							
100%	12 sec	0 sec																																																							
	Touch panel	Continuity is indicated as 100 Ω and below. Each pad must be pressed to perform the following test. 	<table border="1" style="width: 100%; border-collapse: collapse;"> <thead> <tr> <th>Pad</th> <th>Trace</th> <th>Measurement</th> </tr> </thead> <tbody> <tr><td>1</td><td>2 & 8</td><td>Continuity</td></tr> <tr><td>2</td><td>3 & 8</td><td>Continuity</td></tr> <tr><td>3</td><td>4 & 8</td><td>Continuity</td></tr> <tr><td>4</td><td>5 & 8</td><td>Continuity</td></tr> <tr><td>5</td><td>6 & 8</td><td>Continuity</td></tr> <tr><td>6</td><td>7 & 8</td><td>Continuity</td></tr> <tr><td>7</td><td>1 & 9</td><td>Continuity</td></tr> <tr><td>8</td><td>2 & 9</td><td>Continuity</td></tr> <tr><td>9</td><td>3 & 9</td><td>Continuity</td></tr> <tr><td>0</td><td>1 & 8</td><td>Continuity</td></tr> <tr><td>Hold</td><td>1 & 10</td><td>Continuity</td></tr> <tr><td>Defrost</td><td>2 & 10</td><td>Continuity</td></tr> <tr><td>Medium</td><td>3 & 10</td><td>Continuity</td></tr> <tr><td>MED-HI</td><td>4 & 10</td><td>Continuity</td></tr> <tr><td>Time Entry</td><td>5 & 10</td><td>Continuity</td></tr> <tr><td>Stop/Reset</td><td>6 & 10</td><td>Continuity</td></tr> <tr><td>Start</td><td>7 & 10</td><td>Continuity</td></tr> </tbody> </table>	Pad	Trace	Measurement	1	2 & 8	Continuity	2	3 & 8	Continuity	3	4 & 8	Continuity	4	5 & 8	Continuity	5	6 & 8	Continuity	6	7 & 8	Continuity	7	1 & 9	Continuity	8	2 & 9	Continuity	9	3 & 9	Continuity	0	1 & 8	Continuity	Hold	1 & 10	Continuity	Defrost	2 & 10	Continuity	Medium	3 & 10	Continuity	MED-HI	4 & 10	Continuity	Time Entry	5 & 10	Continuity	Stop/Reset	6 & 10	Continuity	Start	7 & 10	Continuity
Pad	Trace	Measurement																																																							
1	2 & 8	Continuity																																																							
2	3 & 8	Continuity																																																							
3	4 & 8	Continuity																																																							
4	5 & 8	Continuity																																																							
5	6 & 8	Continuity																																																							
6	7 & 8	Continuity																																																							
7	1 & 9	Continuity																																																							
8	2 & 9	Continuity																																																							
9	3 & 9	Continuity																																																							
0	1 & 8	Continuity																																																							
Hold	1 & 10	Continuity																																																							
Defrost	2 & 10	Continuity																																																							
Medium	3 & 10	Continuity																																																							
MED-HI	4 & 10	Continuity																																																							
Time Entry	5 & 10	Continuity																																																							
Stop/Reset	6 & 10	Continuity																																																							
Start	7 & 10	Continuity																																																							

Microwave Power Test Procedures



WARNING

To avoid risk of electrical shock, personal injury or death, disconnect power to oven and discharge capacitor before servicing, unless testing requires it.

Power Test (Traditional 1 Liter Test)

Test equipment required is Amana power test kit R0157397 (Fahrenheit), or Menumaster power test kit M95D5 (Celsius).

1. Fill the plastic container to the bottom of the 1000 ml. line with cool tap water.
2. Using the thermometer; Fahrenheit or Celsius, stir the water, measure and record the water temperature.

Initial water temperature should be approximately 60°F.

3. Place container on the center of the oven shelf and heat the water for 63 seconds.

NOTE: Use a watch second hand, not the oven timer.

4. Stir the water, measure and record the temperature of the water after heating time is complete.
5. Subtract the starting water temperature (Step 2), from the ending water temperature (Step 4) to obtain the temperature rise.
6. See the Temperature Chart provided below.

NOTE: Always perform power test three times for accuracy, changing the water after each test is performed.

NOTE: Variation or errors in the test procedure will cause a variance in the temperature rise indication. Additional power tests should be made if temperature rise appears marginal.

NOTE: Low line voltage may cause lower power output (temperature rise).

Temperature Chart

SIXTY-THREE SECONDS run time chart for units less than 1550 Watts cooking power

ΔT (°F)	Cooking Power Output	ΔT (°F)	Cooking Power Output	ΔT (°C)	Cooking Power Output	ΔT (°C)	Cooking Power Output
12	464	27	1046	7	490	15	1050
13	504	28	1085	8	560	16	1120
14	542	29	1124	9	630	17	1190
15	581	30	1162	10	700	18	1260
16	620	31	1201	11	770	19	1330
17	659	32	1240	12	840	20	1400
18	697	33	1279	13	910	21	1470
19	736	34	1317	14	980		
20	775	35	1359				
21	814	36	1395				
22	852	37	1434				
23	891	38	1472				
24	930	39	1511				
25	969	40	1550				
26	1007						

Microwave Leakage Testing Procedures



WARNING

To avoid risk of electrical shock, personal injury or death, disconnect power to oven and discharge capacitor before servicing, unless testing requires it.



WARNING

Check for radiation leakage after servicing. Should the leakage be more than 4mW/cm² inform Maytag immediately. After repairing or replacing any radiation safety device, keep a written record for future reference, as required by D.H.H.S. and HEW regulations. This requirement must be strictly observed. In addition, the leakage reading must be recorded on the service repair ticket while in the customer's home.

Equipment

- Electromagnetic radiation monitor
- 600 cc glass beaker

Procedure For Measuring Radiation Leakage

Note before measuring -

- Do not exceed meter full scale deflection. Leak monitor should initially be set to the highest scale.
 - To prevent false readings the test probe should be held by the grip portion of the handle only.
 - The scan speed is equal to one inch per antenna revolution or one inch per second if antenna speed is unknown.
 - Areas to be checked are all door seal areas and any venting parts.
 - Leakage with the outer panel removed ...4mW/cm² or less.
 - Leakage for fully assembled oven with door normally closed ...4mW/cm² or less.
 - Leakage for a fully assembly oven (before the latch switch (primary) is interrupted) while pulling the door ... 4mW/cm² or less.
1. Pour 275 cc ±15 cc (9 oz ±1/2 oz) of 20°C ± 5°C (68°F ± 9°F) water in a beaker which is graduated to 600 cc and place the beaker in the center of oven.
 2. Set the radiation monitor to 2450 MHz and use it following the manufacturer's recommended test procedure to assure correct results.
 3. While measuring the leakage, always use the two inch (5 cm) spacer supplied with the probe.
 4. Press the start pad or turn on the timer and with the magnetron oscillating, measure the leakage by holding the probe perpendicular to the surface being measured.

Measurement With the Outer Panel Removed



DANGER

Avoid contacting any high voltage components.

Whenever you replace the magnetron, measure for radiation leakage before the outer panel is installed and after all necessary components are replaced or adjusted. Special care should be taken in measuring around the magnetron.

Measurement With a Fully Assembled Oven

After all components including the outer panel are fully assembled, measure for radiation leakage around the door periphery, the door viewing window, the exhaust opening, and air inlet openings.

Record Keeping and Notification After Measurement

1. After any adjustment or repair to a microwave oven, a leakage reading must be taken. Record this leakage reading on the repair ticket even if it is zero.
2. A copy of the repair ticket and the microwave leakage reading should be kept by the repair facility.

Disassembly Procedures



To avoid the risk of electrical shock, personal injury or death, disconnect power to oven and discharge capacitors before following any disassembly procedure.

High voltage is present at the high voltage terminal of the high voltage transformer during any cooking cycle.

It is neither necessary or advisable to attempt measurement of the high voltage.

Before touching any oven components or wiring, always unplug the oven from its power source and discharge capacitor.

Disconnecting Wire Terminals

All wire terminals are locking-type terminals. Proceed as follows to disconnect wire terminals:

Insulated terminals:

Grasp insulator pod and pull back.

DO NOT PULL ON WIRE.

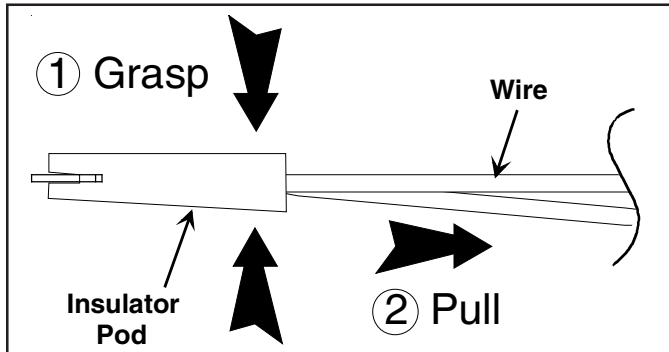

Non-insulated terminals:

Use a small blade screwdriver to depress locking-tab and pull on terminal.

DO NOT PULL ON WIRE.

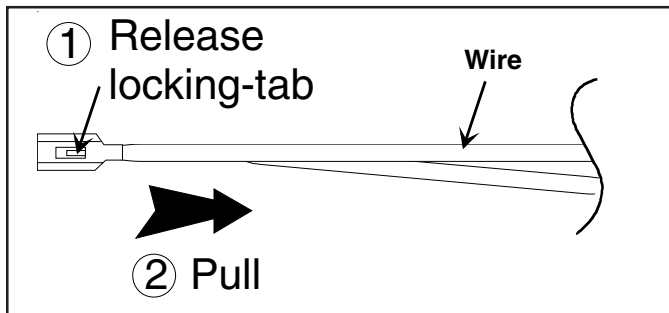

Outer Case

1. Disconnect power to oven.
2. Remove screws securing outer case to unit.
3. Slide outer case towards rear of unit.
4. Reassemble in reverse order.

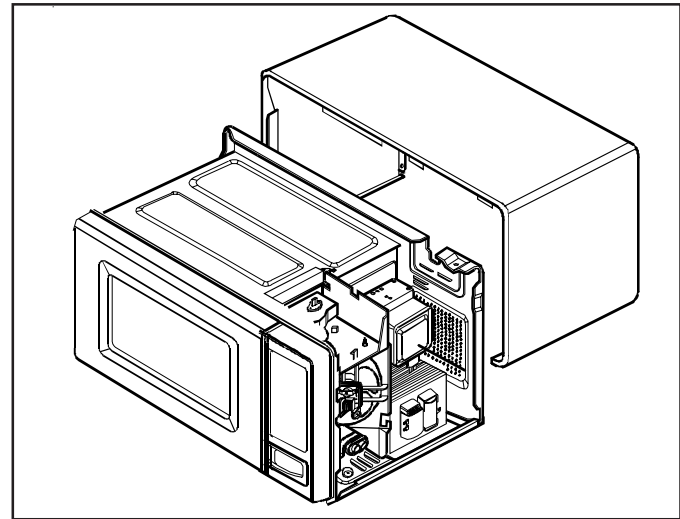

Door Assembly



A microwave leakage test must be performed anytime a door assembly is removed, replaced, disassembled, or adjusted for any reason.

Door Removal

1. Disconnect power to oven.
2. Open oven door, remove top hinge cap, and slowly lift door to disengage the hinge pins at top and bottom.

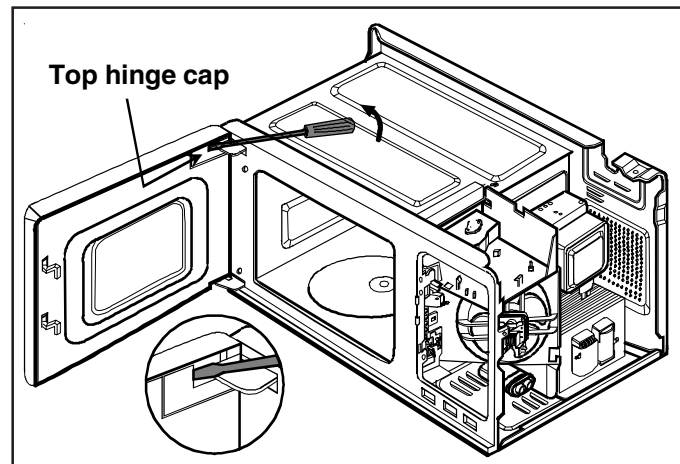

3. To re-install door, place bottom pin into slot first, then align top pin.
4. Replace top hinge cap.

Disassembly Procedures

WARNING

To avoid the risk of electrical shock, personal injury or death, disconnect power to oven and discharge capacitors before following any disassembly procedure.

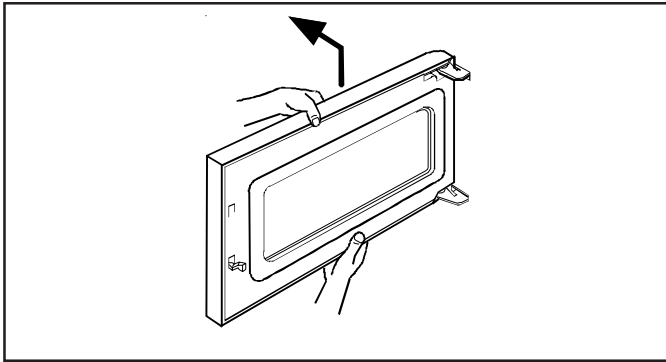

CAUTION

A microwave leakage test must be performed anytime a door assembly is removed, replaced, disassembly, or adjusted for any reason.

NOTE: When disassembling door, use caution to prevent deformation of slats on door frame/choke assembly.

Door Disassembly

1. Disconnect power to oven.
2. Remove oven door, (see "Door Removal").
3. Begin at the bottom of the door near hinge, insert flat blade screwdriver between choke cover and outer door panel. Gently pry upward on choke cover to release tabs. Work in clockwise direction to remove choke cover.

CAUTION

To avoid property damage, care must be taken when prying choke cover from oven door.

4. Slide latch assembly upward and pull away from door frame to release tabs from frame.
5. Disconnect latch spring from door frame.
6. Begin at hinge side of door near bottom, insert flat blade screwdriver between door frame/choke assembly and outer door panel. Gently pry outer door panel away from door frame to release tabs. Work in clockwise direction to remove door frame.
7. Reassemble in reverse order.

Control Panel Removal

1. Disconnect power to oven and remove outer case, (see "Outer Case" procedure).
2. Disconnect and label wires from controller/timer.
3. Open oven door.
4. Remove screw securing top of control panel to cavity. Lift control panel up and out to release bottom tabs.

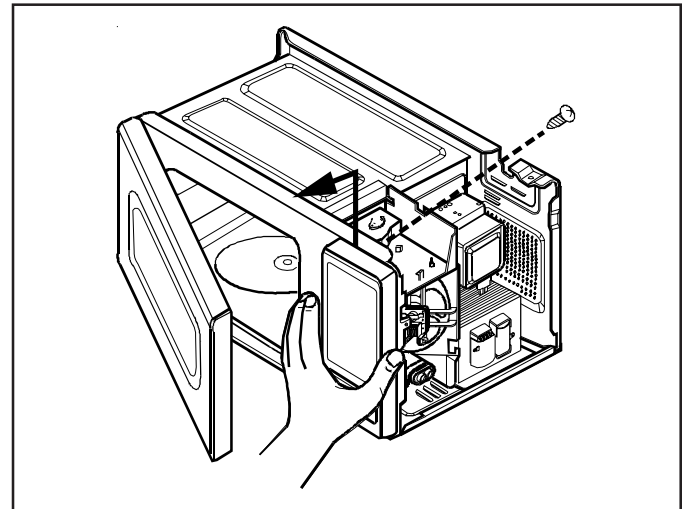

5. Reassemble in reverse order.

NOTE: Be sure to re-install ground wire when securing control panel to cavity.

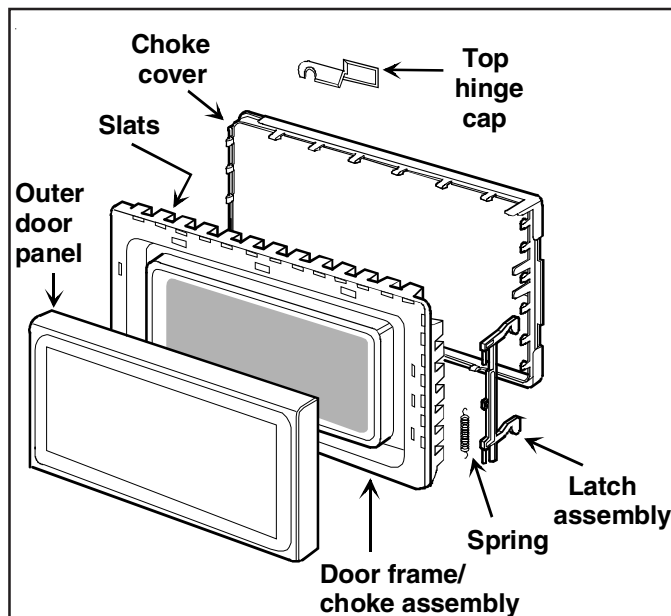

Disassembly Procedures



To avoid the risk of electrical shock, personal injury or death, disconnect power to oven and discharge capacitors before following any disassembly procedure.

Controller Removal (Electronic Models)

1. Disconnect power to oven and remove outer case, (see "Outer Case" procedure).
2. Remove control panel, (see "Control Panel" section).
3. Disconnect keypad ribbon connector .

NOTE: Caution should be used when removing ribbon from connector. Ribbon cable has two holes to align and lock ribbon to connector.

4. Remove screws securing controller to control panel assembly.

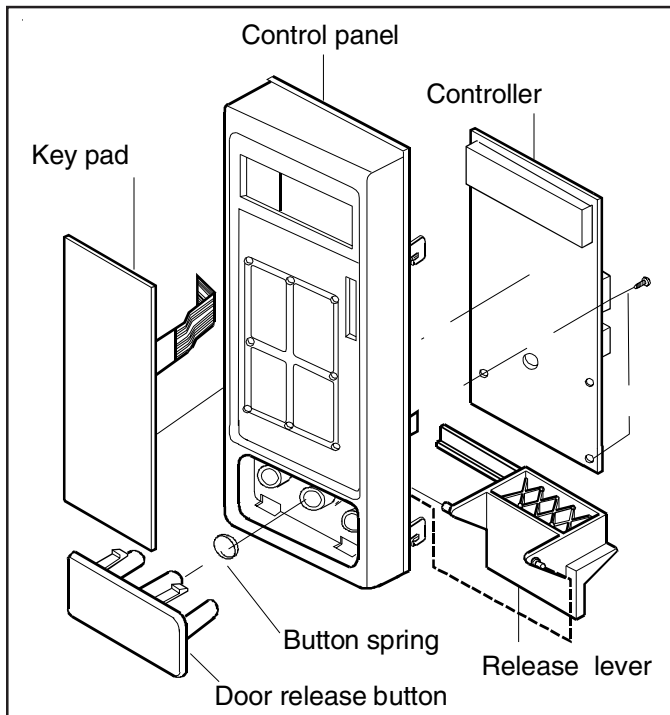

5. Reassemble in reverse order.

NOTE: Do not flex controller.

Key Pad Removal

1. Disconnect power to oven and remove outer case, (see "Outer Case" procedure).
2. Remove control panel, (see "Control Panel Removal" section).
3. Disconnect ribbon connector.
4. Peel off failed key pad from control panel.
6. Reassemble in reverse order.

Timer Removal (Dial Models)

1. Disconnect power to oven and remove outer case (see "Outer Case" procedure).
2. Remove control panel, (see "Control Panel" section).
3. Remove screws securing timer to control panel.
4. Remove knob from timer.
5. Reassemble in reverse order.

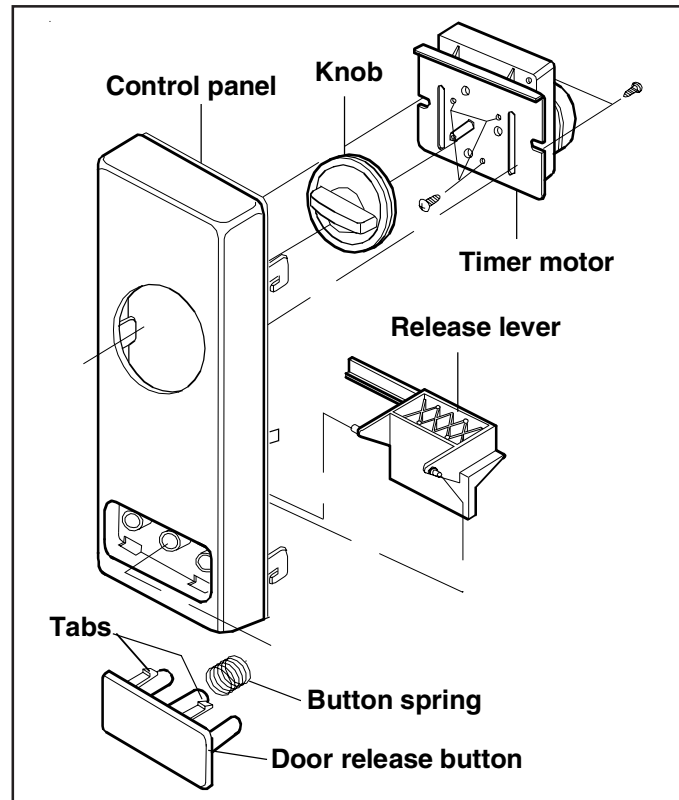

All Models

Door Release Lever / Release Button / Spring

1. Disconnect power to oven and remove outer case (see "Outer Case" procedure).
2. Carefully pry tab on control panel to disengage release lever from control panel.
3. Push (4) tabs on door release button and remove button from control panel.
4. Remove spring from door release button.
5. Reassemble in reverse order.

Disassembly Procedures



WARNING

To avoid the risk of electrical shock, personal injury or death, disconnect power to oven and discharge capacitors before following any disassembly procedure.

Interlock Switches

Primary switch is operated by bottom latch arm.

Interlock Switch Removal

1. Disconnect power to oven and remove outer case, (see "Outer Case" procedure).
2. Remove control panel, (see "Control Panel" section).
3. Test interlock switches before removing, (see testing procedures).
4. Disconnect and label wire connections.
5. Remove switches by carefully releasing locking tabs on switch bracket and tilting switches to remove from switch bracket.

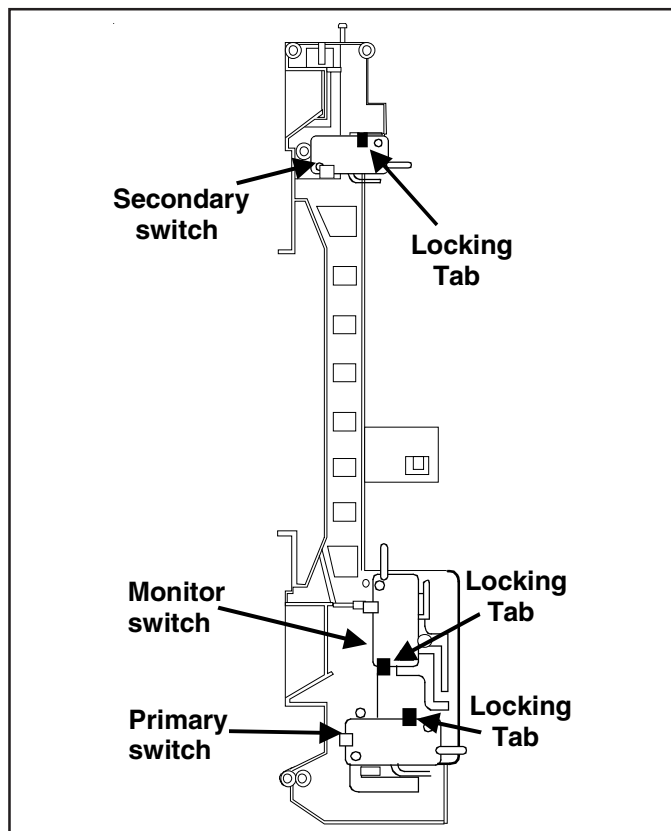

NOTE: After repairing the door or the interlock system, it is necessary to check the switch continuity before operating the oven.



CAUTION

Before replacing a blown monitor fuse, test the primary interlock switch, secondary interlock switch, monitor switch, and power relay contacts for proper operation. If the monitor fuse is blown by a failed switch operation, all switches and controller must be replaced.

Adjusting Interlocks

The interlock monitor, primary, and secondary switches act as a final safety switch, protecting the operator from microwave energy. After adjusting the interlock switch assembly, verify wires are correctly connected.

For door fit and switch operation, switch bracket is adjustable.

1. Disconnect power to oven and remove outer case, (see "Outer Case" procedure).
2. Loosen switch bracket mounting screws.
3. Close oven door, move switch bracket toward rear of oven until door gap is less than $\frac{1}{64}$ -inch (0.5 mm).
4. Hold switch bracket securely for proper switch operation and door fit, retighten screws.
5. Open oven door slowly, watching the switches. Verify switches release in the following order.
 - Primary interlock switch
 - Secondary interlock switch
 - Interlock monitor switch

NOTE: Adjust the switch bracket until all switches operate in proper sequence.

6. Close the oven door slowly, watching the switches. Verify switches activate in the following order.
 - Interlock monitor switch
 - Secondary interlock switch
 - Primary interlock switch
7. When proper switch sequence has been achieved, tighten the switch bracket securely.



CAUTION

A microwave leakage test must be performed anytime a door assembly is removed, replaced, disassembled, or adjustment of switch bracket is made.

High Voltage Capacitor

High voltage capacitor should always be discharged by shorting a terminal to a chassis ground. The capacitor has a internal "shunt" resistor, but the mechanical discharge should always be performed to avoid personal injury.

High Voltage Capacitor Removal

1. Disconnect power to oven and remove outer case, (see "Outer Case" procedure).
2. Discharge high voltage capacitor.
3. Remove and label wire leads from capacitor terminals.
4. Push the end of capacitor straps towards rear of oven to release strap from fan shroud.
5. Slide capacitor out of slots and remove capacitor.
6. Reassemble in reverse order.

Disassembly Procedures



WARNING

To avoid the risk of electrical shock, personal injury or death, disconnect power to oven and discharge capacitors before following any disassembly procedure.

Diode

1. Disconnect power to oven and remove outer case, (see "Outer Case" procedure).
2. Discharge high voltage capacitor, (see "High Voltage Capacitor" section).
3. Disconnect diode from high voltage capacitor and remove screw securing diode to ground.
4. Reassemble in reverse order.

Transformer

1. Disconnect power to oven and remove outer case, (see "Outer Case" procedure).
2. Discharge high voltage capacitor, (see "High Voltage Capacitor" section).
3. Disconnect and label wire leads from transformer.
4. Remove screws securing transformer and remove.
5. Reassemble in reverse order.

Fuse Block / Filter Assembly

1. Disconnect power to oven and remove outer case, (see "Outer Case" section).
2. Disconnect and label wires.
3. Carefully lift rear of fuse block assembly to release assembly from locating pin.
4. Slide fuse block assembly towards front of oven to remove.
5. Reassemble in reverse order.

Fuse

Fuse Removal

Fuse is located on the noise filter board.

1. Disconnect power to oven and remove outer case, (see "Outer Case" section).
2. Remove and replace fuse, reassemble in reverse order.



CAUTION

Before replacing a blown monitor fuse, test the primary interlock switch, secondary interlock switch, monitor switch, and power relay contacts for proper operation. If the monitor fuse is blown by a failed switch operation, all switches and controller must be replaced.

Magnetron

Magnetron is mounted on the side of the cavity.

1. Disconnect power to oven and remove outer case, (see "Outer Case" section).
2. Discharge high voltage capacitor, (see "High Voltage Capacitor" section).
3. Remove filter assembly from magnetron terminals.
4. Remove air duct.
5. Remove screws securing magnetron to the wave guide.

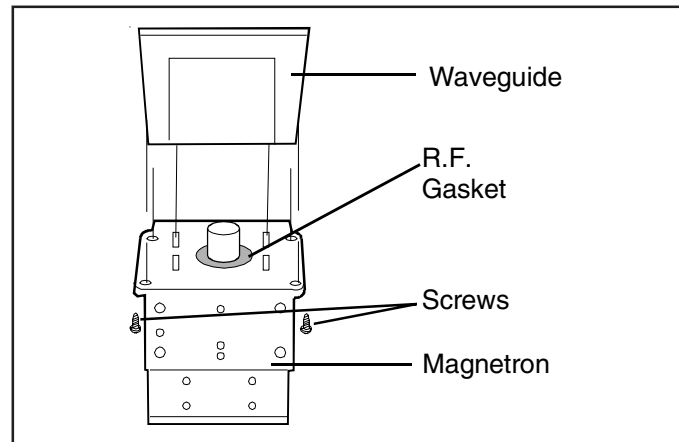

6. Reassemble in reverse order.

NOTE: When replacing magnetron, make sure gasket is in correct position and in good condition.



CAUTION

During replacement of magnetron, be certain the R.F. anode gasket is in place around the anode stud.



WARNING

A microwave leakage test must be performed anytime a magnetron assembly is removed, replaced, disassembled, or adjusted for any reason.

Fan Motor

1. Disconnect power to oven and remove outer case (see "Outer Case" section).
2. Discharge high voltage capacitor, (see "High Voltage Capacitor" section).
3. Remove rear air guide.
4. Remove screws securing diode to back panel.
5. Disconnect and label wires to high voltage capacitor.
6. Remove screws securing fan shroud to back panel and remove fan shroud from cavity.

Disassembly Procedures



To avoid the risk of electrical shock, personal injury or death, disconnect power to oven and discharge capacitors before following any disassembly procedure.

7. Disconnect wires from fan motor terminals.
8. Carefully note fan blade direction and placement on motor shaft.
9. Pull fan blade from motor shaft.
10. Remove screws securing motor to shroud and remove motor.
11. Reassemble in reverse order.

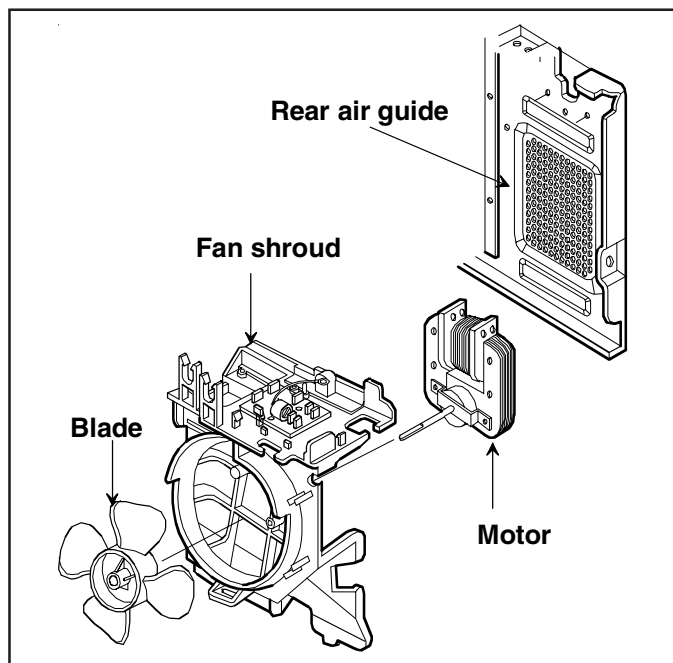

Antenna

1. Open oven door to gain access to oven tray.
2. Using suction cup tool (59001235). Remove oven tray, by placing suction cup on oven tray and raising oven tray and removing it from the oven cavity.
3. Remove center portion of plastic insert from plastic rivet.
4. Lift upward on antenna to remove.
5. Reassemble in reverse order.

NOTE: When replacing antenna push outer portion of plastic rivet flush with the bottom of new antenna. Place new antenna onto stirrer shaft, align rivet holes and push rivet into place. Once rivet is in place inner insert into rivet.

Stirrer Motor

1. Disconnect power to oven.
2. Place oven on it's back.

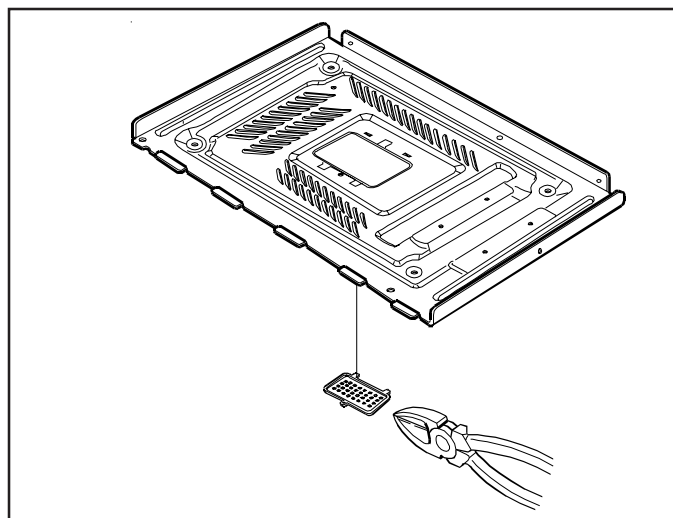

3. Remove bottom plate cover, by cutting metal tabs

NOTE: When reinstalling plate cover use screw provided.

4. Disconnect wires from motor terminals.
5. Remove screws securing motor to oven cavity.

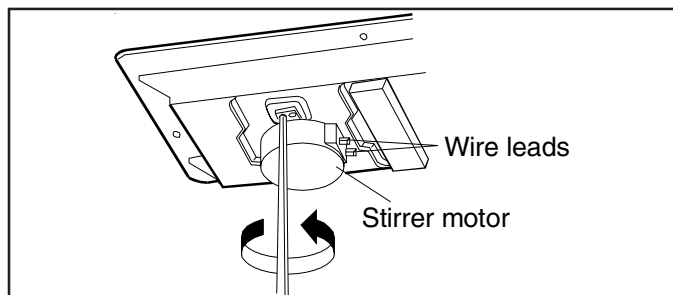

6. Replace and reassemble in reverse order.

Cavity Thermostat

The cavity thermostat is located on top left side of cavity. Thermostat is a non–resettable thermostat.

1. Disconnect power to oven and remove outer case, (see "Outer Case" section).
2. Discharge high voltage capacitor, (see "High Voltage Capacitor" section).
3. Carefully bend one tab to release thermostat.
4. Disconnect wires from oven thermostat and replace thermostat.
5. Reassemble in reverse order.

Light Socket / Bulb Assembly

1. Disconnect power to oven and remove outer case, (see "Outer Case" section).
2. Disconnect wire terminal plug.
3. Carefully bend one tab to release socket.
4. Remove light socket / bulb assembly.
5. Replace and reassemble in reverse order.

Wiring Diagram and Schematic



WARNING

To avoid the risk of electrical shock, personal injury or death, disconnect power to oven and discharge capacitors before following any disassembly procedure.

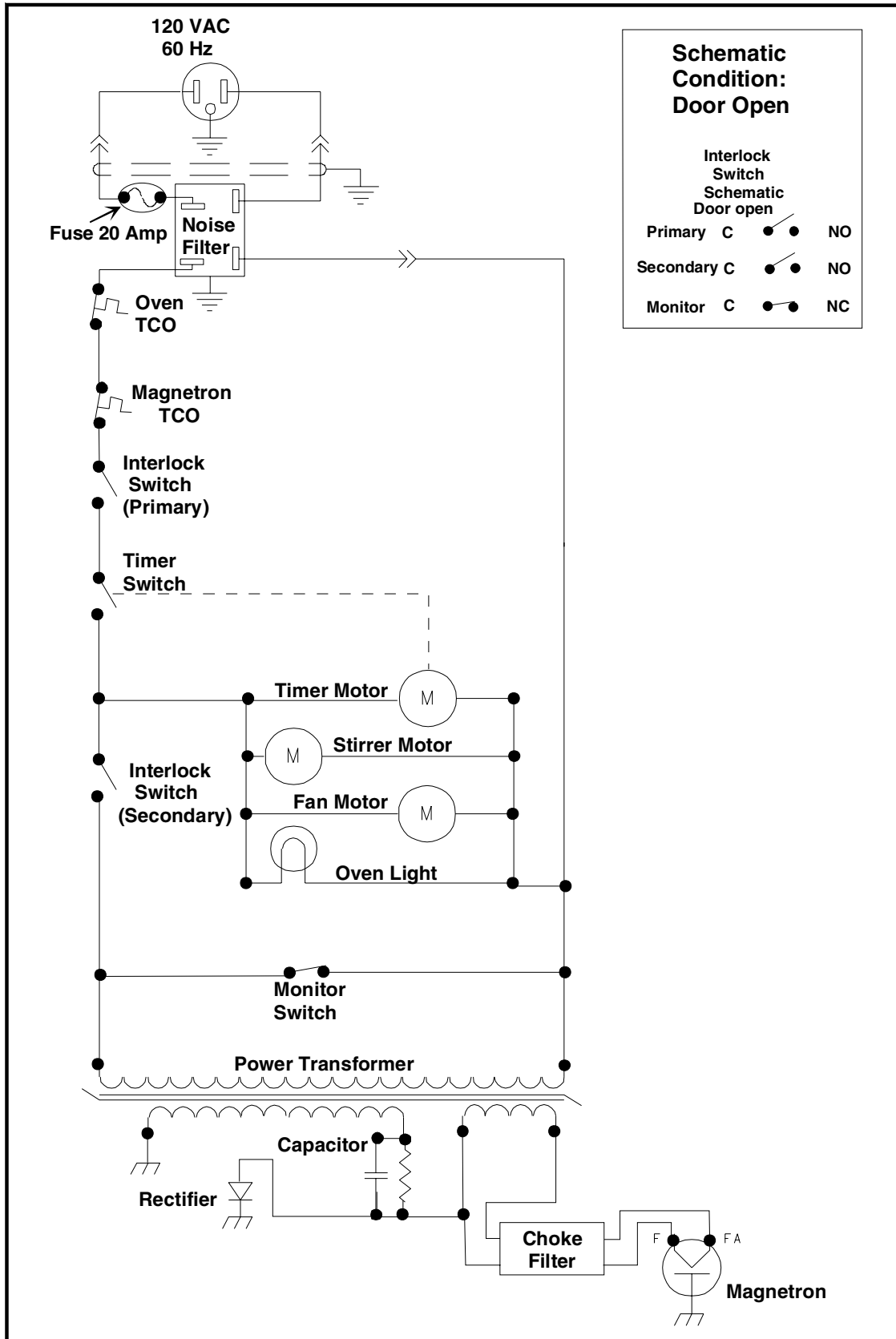

LD10D2

Wiring Diagram and Schematic



To avoid the risk of electrical shock, personal injury or death, disconnect power to oven and discharge capacitors before following any disassembly procedure.

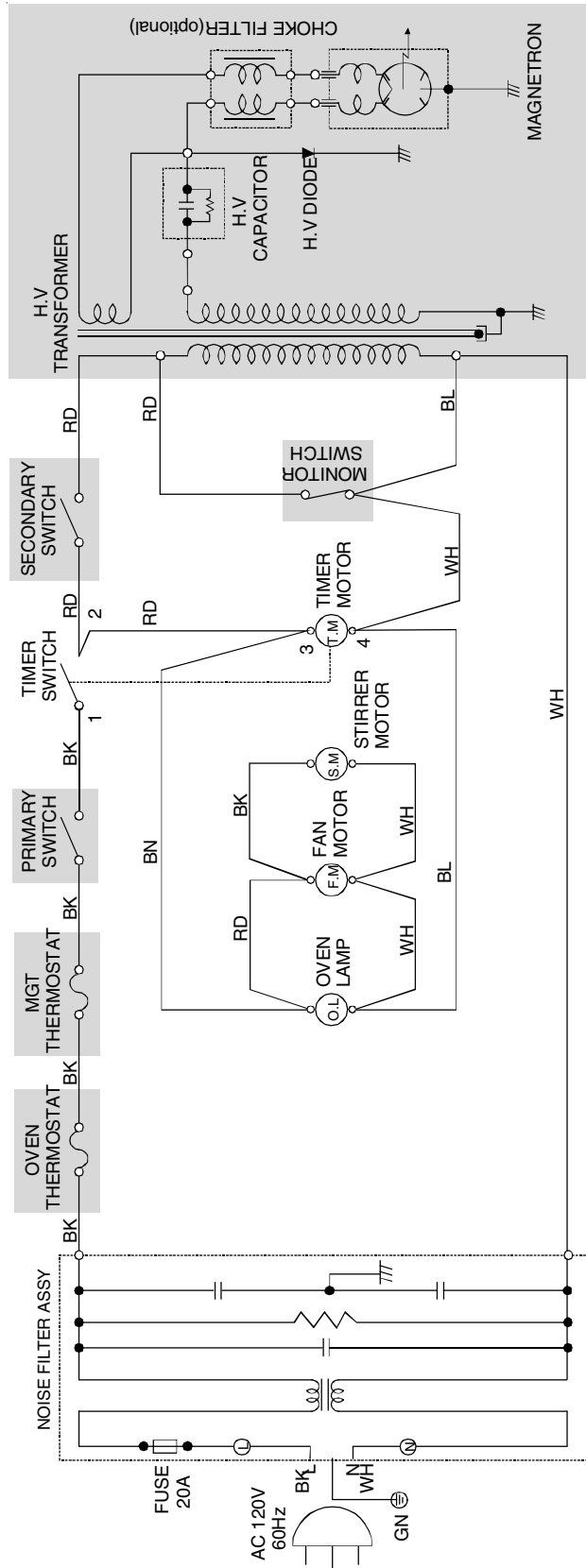

** NOTE : DOOR IS OPENED.

BK : BLACK BL : BLUE BN : BROWN
RD : RED WH : WHITE GN: GREEN

Important Safety Note: The shaded areas on this schematic diagram incorporate special features important for protection from microwave radiation, fire, electrical shock, and hazards. When servicing it is essential that only manufacturer's specified parts be used for the critical components in the shaded areas of the schematic diagram.

NOTICE: Since this basic schematic diagram, the values of components and some partial connections are subject to change for improvement.

LD10D2

Wiring Diagram and Schematic



WARNING

To avoid the risk of electrical shock, personal injury or death, disconnect power to oven and discharge capacitors before following any disassembly procedure.

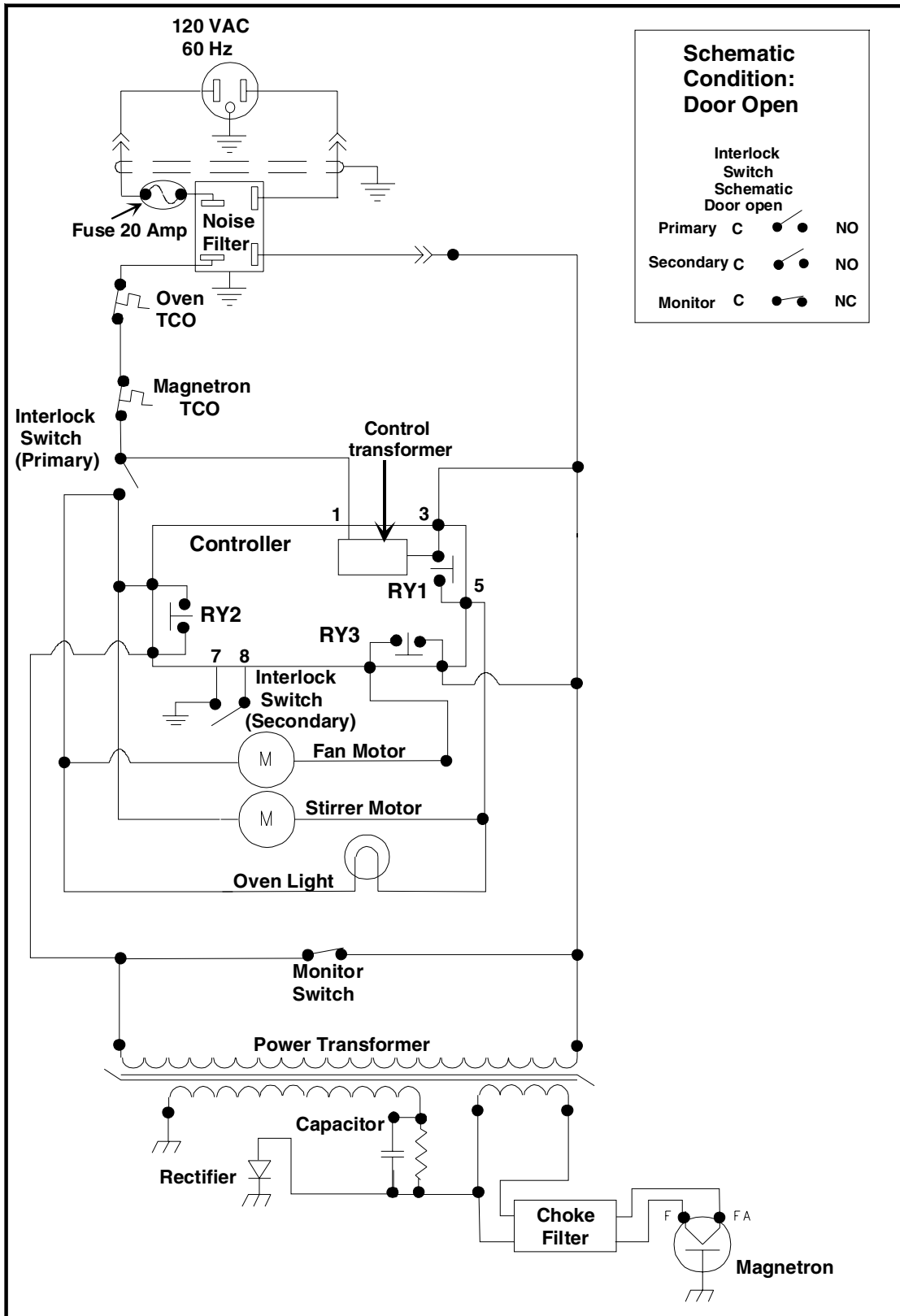

LD10MP and LD10MPS

Wiring Diagram and Schematic

WARNING To avoid the risk of electrical shock, personal injury or death, disconnect power to oven and discharge capacitors before following any disassembly procedure.

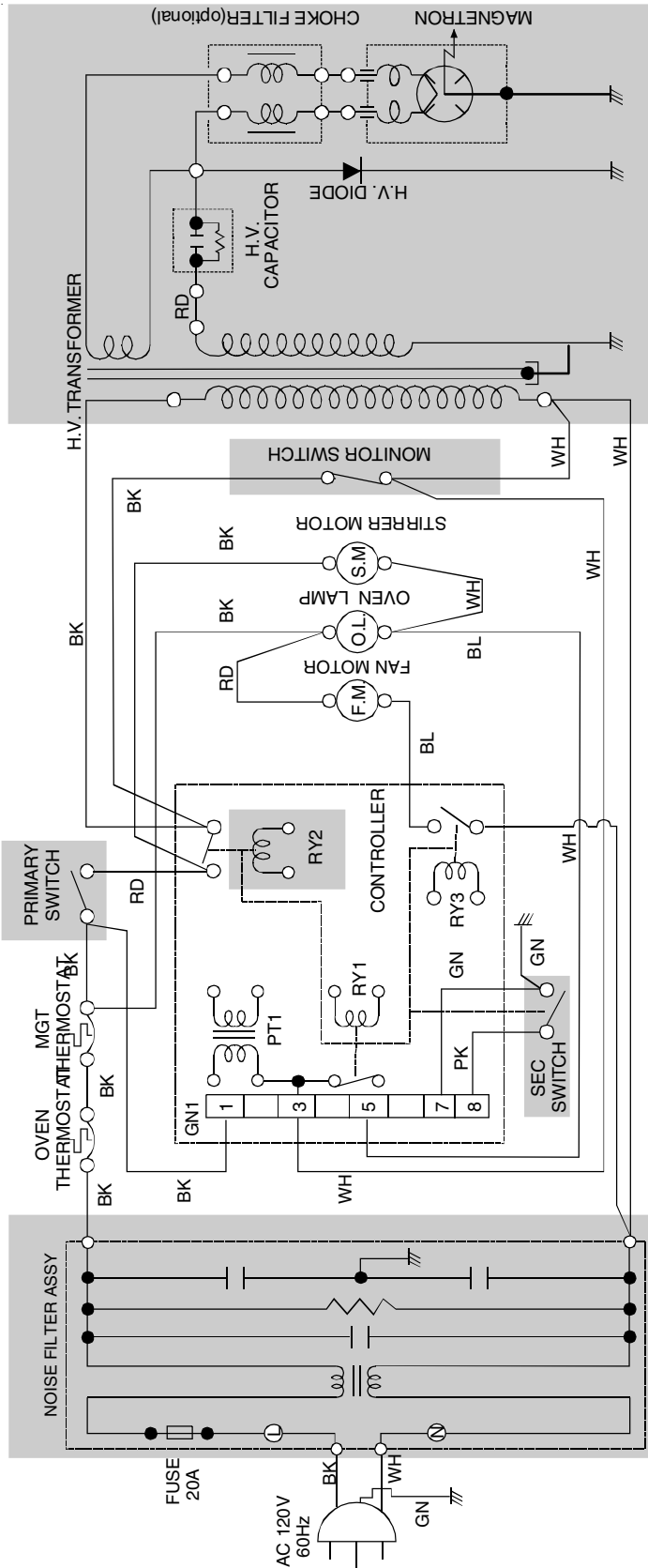

BK : BLACK BL : BLUE RD : RED
 WH : WHITE PK : PINK GN : GREEN

** NOTE : DOOR IS OPENED.

Important Safety Note: The shaded areas on this schematic diagram incorporate special features important for protection from microwave radiation, fire, electrical shock, and hazards. When servicing it is essential that only manufacturer's specified parts be used for the critical components in the shaded areas of the schematic diagram.

NOTICE: Since this basic schematic diagram, the values of components and some partial connections are subject to change for improvement.

LD10MP and LD10MPS

Wiring Diagram and Schematic



WARNING

To avoid the risk of electrical shock, personal injury or death, disconnect power to oven and discharge capacitors before following any disassembly procedure.

This page intentionally left blank.

Appendix A

Operation—LD10MP and LD10MPS

Control Panel

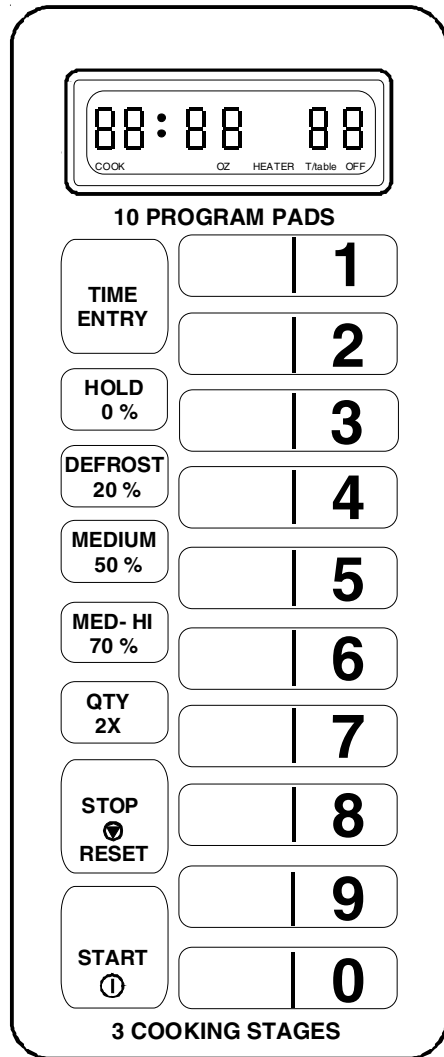

Display

Some items in display can be seen but will not glow.

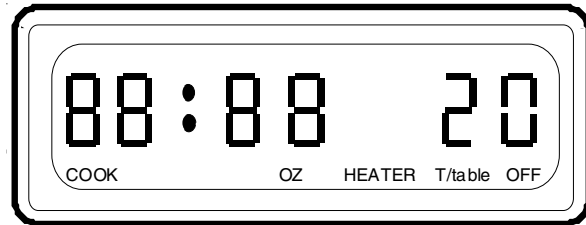

Pads

TIME ENTRY	Use to enter heating time without changing preprogrammed number pads.
Pads 1-0	Use to begin heating with preprogrammed times and power levels or to enter times for "Manual Time Entry" cooking.
HOLD 0% DEFROST 20% MEDIUM 50% MED-HI 70%	Use to select power level. Oven can heat at full or reduced power. If oven power level is set to 0% oven does not heat for programmed time. If no power level is selected, oven operates at 100% power.
STOP/RESET	Use to exit programming mode and stop cooking during cooking cycle.
START	Use to start "Manual Time Entry" program or restart interrupted cooking cycle. Use to advance to next user option. Use to save times and power levels when programming pads.
QTY 2X	Use to automatically increase the programmed time for double quantities.

Operation—LD10MP and LD10MPS

Cooking Displays

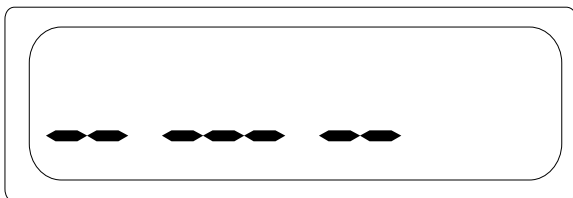

Shows when power is connected to oven. Open and close door to clear.



READY shows when oven control will accept entries. Appears after oven door is opened and closed.

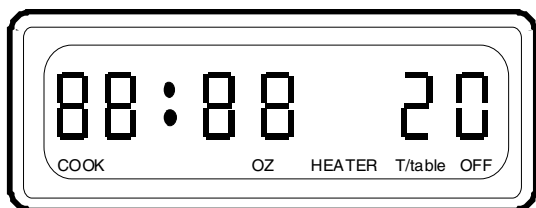

88:88 shows heating time. When more than 1 heating stage is programmed, total time for all stages displays.

COOK shows when oven is operating.

20 indicates the microwave power level used. If power level does not show, oven is heating at 100% power.

Programming Displays



Indicates programming mode. See "Programming" section of manual for programming procedure.

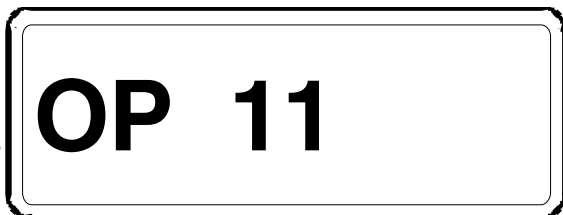

Indicates programming user options mode. See "User Options" section of manual for programming procedure.

Operation—LD10MP and LD10MPS



CAUTION

To avoid damaging oven, only heat in microwave oven when turntable is in place.



CAUTION

To avoid fire, do not dry newspapers or clothes in microwave oven.

Preprogrammed Times and Cook Level
All preprogrammed pads are set at full power.

Option: Single Digit

Pads	Heating Times
1	10 sec.
2	20 sec.
3	30 sec.
4	45 sec.
5	1 min.
6	1:30 min.
7	2 min.
8	3 min.
9	4 min.
0	5 min.

Interrupting Operation

- Open oven door to interrupt operation. Oven fan continues to operate. Close door and press *START* pad to resume oven operation.
- Press *STOP/RESET* pad to interrupt operation. Display continues to show countdown time. Close oven door and press the *START* pad to resume oven operation and countdown timing.

Canceling Mistakes

- If oven is operating, press *STOP/RESET* pad once to stop oven, then again to clear display.
- If oven door is open and time shows in display, close oven door and press *STOP/RESET* pad to clear display.

Operating Preprogrammed Pads

Oven has 10 – 20 preprogrammed number pads. Instructions are written for factory programmed ovens. Ovens that are reprogrammed can respond differently than described below.

1. Open oven door, place food in oven, and close oven door.
 - If pad is not pressed within 30 seconds, open and close oven door again.
2. Press desired number pad.
 - Oven operates and time counts down.
3. Oven stops heating and oven signal sounds when heating timing elapses.

Operating QTY 2X Pads

1. Press QTY 2X pad.
2. Press desired number pad.

Example: Press QTY 2X pad then pad 1 = 18 sec.

NOTE: This feature automatically sets the time preprogrammed for multiple cooking items. The pad times are not representative of the preprogrammed double digit option.

Option: Double Digit

Pads	Heating Times	Pads	Heating Times
01	10 sec.	11	20 sec.
02	20 sec.	12	40 sec.
03	30 sec.	13	1 min.
04	45 sec.	14	1:30 min.
05	1 min.	15	2 min.
06	1:30 min.	16	3 min.
07	2 min.	17	4 min.
08	3 min.	18	6 min.
09	4 min.	19	8 min.
10	5 min.	20	10 min.

Manual Time Entry

Manual Time Entry feature allows the operator to enter time and power levels, and heat without changing the preprogrammed pads.

1. Open oven door, place food in oven, and close door.
 - Display shows “READY”.
 - If pad is not pressed within 30 seconds, open and close oven door again.
2. Press *TIME ENTRY* pad.
 - Display shows “00:00”.
3. Press number pads to enter desired cooking time.
 - For example, to heat for 2 minutes 30 seconds, press *2*, *3*, and *0* pads.

Operation—LD10MP and LD10MPS

4. Press desired power level pad to change power level.
 - If a power level pad is not pressed, oven defaults to 100% power.
 - For example, pressing MEDIUM 50% pad sets oven to 50% power.
 - Display shows current power level if other than 100 percent power.
5. Press *START* pad.
 - Oven operates and time counts down.
6. Oven stops heating and oven signal sounds when heating timing elapses.

Programming

Preprogrammed Number Pads

Oven has 10 preprogrammed number pads. Follow instructions below to program heating times and power levels for customized cooking.

1. Open oven door.
 - If door is closed or *RESET* pad is pressed before finishing programming sequence, oven exits programming mode.
2. Press and hold pad *1* for approximately 5 seconds.
 - After 5 seconds, signal sounds. Display shows "PROGRAM" indicating program mode.
3. Press desired number pad.
 - Display shows heating time, "COOK LEVEL" and power level if other than 100 % power.
4. Press number pads to enter desired cooking time.
 - For example, to heat for 2 minutes 30 seconds, press *2, 3, and 0* pads.
5. Press desired power level pad to change power level.
 - If a power level pad is not pressed, oven defaults to 100% power.
 - For example, pressing MEDIUM 50% pad sets oven to 50% power.
 - Display shows current power level if other than 100 % power.
6. Press *START* pad to save new heating time and power level in oven memory.
 - Repeat step 3-6 to program additional pads.
7. Press *RESET* pad or close oven door to exit programming mode.

Multiple Heating Stages

Follow instructions below to program oven to perform 3 consecutive heating cycles without interruption.

1. Open oven door.
 - If door is closed or *RESET* pad is pressed before finishing programming sequence, oven exits programming mode.
2. Press pad *1* for approximately 5 seconds.
 - After 5 seconds, signal sounds. Display shows "PROGRAM" indicating program mode.
3. Press desired number pad.
 - Display shows heating time and preprogrammed number.
4. Press number pads to enter desired cooking time.
 - For example, to heat for 2 minutes 30 seconds, press *2, 3, and 0* pads.
5. Press desired power level pad to change power level.
 - If a power level pad is not pressed, oven defaults to 100% power.
 - For example, pressing MEDIUM 50% pad sets oven to 50% power.
 - Display shows current power level if other than 100 % power.
6. Press *TIME ENTRY* pad.
 - Display briefly shows "STAGE 2" . Then cook time and power level for stage show in display.
 - Repeat steps 5-6 to create additional stages.
7. Press *START* pad to save new heating time and power level in oven memory.
8. Press *RESET* pad or close oven door to exit programming mode.

Operation—LD10MP and LD10MPS

User Options

Follow the instructions below to customized the microwave oven's operation. End-of-cycle signal, maximum heating time and other options can be changed to meeting your cooking needs.

1. Open oven door.
 - If door is closed or *RESET* pad is pressed before finishing programming sequence, oven exits programming mode.
2. Press and hold pad 2 for approximately 5 seconds.
 - After 5 seconds, signal sounds. Display shows "OPTION".
3. Press number pad that matches desired option.
 - "OP" represents optional program mode, first number represents option number and second number represents functions currently selected for option.
4. Press number pad to change option setting.
5. Press *START* pad to save changes.
 - Repeat steps 3-5 to change additional options.
6. Press *STOP/RESET* pad or close oven door to exit programming mode.

Numbered Pads	Display	Options () = Factory Setting
1 End of Cycle Beep	OP:10 OP:11 OP:12	3 second continuous beep (Continuous Beep until door is opened) 5 beeps bursts until door is opened
2 Speaker Volume	OP:20 OP:21 OP:22 OP:23	Eliminates beep Sets volume to low; 60-70dB Sets volume to medium; 70-80dB (Sets volume to high; 80-90dB)
3 Key Beep	OP:30 OP:31	Prevents signal when pad is pressed. (Allows signal when pad is pressed.)
4 Keyboard Enable Window	OP:40 OP:41	(30 seconds after oven door is opened, keyboard disabled) 2 minutes after oven door is opened, keyboard disabled
5 Add Time during Heating	OP:50 OP:51	(Prevents adding heating time while oven is heating.) Allows adding heating time while oven is heating.
6 Reset Door Open	OP:60 OP:61	(Cancels heating time count down after door is opened during cycle.) Allows oven to resume heating time countdown after door is opened during cycle.
7 Maximum Heating Time	OP:70 OP:71	Allows 10 minutes of heating time. (If more than 10 min. is programmed in this setting, unit will beep 3 times and no programming will occur.) (Allows 60 minutes of heating time.)
8 Manual Operation	OP:80 OP:81	Allows use of preprogrammed pads only. (Allows use of manual time entry and preprogrammed pads.)
9 Double Digit	OP:90 OP:91	(Allows use of double digit only.) Allows use of single digit only.

Cooking Guidelines

The Amana Microwave Oven can make your job easier. You'll cook ahead and pre-portion more. You'll also spend less time preparing special-order dishes.

To be sure of consistently good results, remember a few simple guidelines.

How Microwave Ovens Heat Food

All food and liquid molecules have positive and negative particles which are in constant, but slow, motion. (Positive and negatives attract and repel each other like magnets.) In microwave cooking this molecular action is then accelerated. The instant microwaves bombard food which agitate the molecules. Agitation causes friction as molecules rub and bump into each other at an increased rate. Friction results in heat that cooks food and boils water.

Once the microwaves stop, this friction action continues by itself, eventually tapering off and returning to normal molecular action.

Microwaves penetrate food to a depth of $\frac{3}{4}$ " to $1\frac{1}{2}$ ". As cooking begins, heat is spread by conduction to the interior portion of the food just as in conventional cooking methods.

Food Variables

Microwave cooking can be directly affected by different food variables.

The **shape** of foods can greatly affect the amount of cooking time. Foods that are flat and thin heat faster than foods which are chunky. For example, a casserole will cook faster in a flat dish, rather than if heaped in a small dish. Foods cut into small pieces will cook faster than large-shaped foods. Pieces should be of a uniform size and shape for more uniform cooking, or the smaller pieces will cook faster. The greatest amount of heating takes place within $\frac{3}{4}$ " of the food's surface. The interior of large food items, or dense foods, is heated by the heat conducted from the outer food layer. The most uniform heating occurs in flat, doughnut-shaped foods. For best results, cook foods together which have similar sizes and shapes.

The **quantity** or volume of a food can affect the amount of cooking time. As the volume of the food is increased, the time required to cook or heat the item increases almost proportionately. If twice the amount of food is placed in the oven, it will take almost twice as long to cook. To determine the time for larger quantities, multiply the individual serving time by the increased amount, then reduce the total heating time by about 20%.

The **density** of foods can greatly affect the amount of cooking time. Porous foods, such as breads, cakes or pastries, will heat much more quickly than dense meats of the same size. Porous foods absorb microwaves quickly throughout. Meats absorb microwaves mostly at the exterior surface, and the interior is heated by conduction, increasing the cooking time. Meats can be cooked in a sauce, if desired. Due to the moisture content, a sauce will heat rapidly. The heat will transfer to the meat, so the meat will heat faster due to heat by conduction as well as by microwaves.

The **starting temperature** of foods affects the amount of cooking time. Each temperature degree that the food item is to raise must be supplied with a definite amount of energy. Lower initial starting temperatures require more energy and more time to cook. Therefore, refrigerator temperature foods require a longer cooking time than room temperature foods. Foods already slightly warm will heat very quickly in the oven.

The **moisture content** of foods affects the amount of cooking time. The higher the moisture content is in a food the longer the amount of cooking time.

The **fat and sugar content** of foods affects the amount of cooking time. Foods containing high fat and sugar levels heat very quickly and may reach much higher temperatures than foods having low fat and sugar levels. Foods having lower fat and sugar levels require longer cooking times.

The **arrangement** of food within a microwave oven cavity affects the way in which the food cooks. A "round" arrangement is best. Use round utensils whenever possible. Also, arrange foods such as baked potatoes in a circle, rather than in rows, for cooking. When only one food item is being cooked, place it in the center of the oven glass shelf for cooking.

Manipulation of Foods

Sometimes recipes suggest manipulating or moving food during cooking. There are several forms of manipulation:

Stirring is required less often in microwave cooking than in conventional cooking. In conventional cooking, you use a spoon to move food up from the bottom of a pan to evenly distribute the heat. In microwave cooking, you still stir to redistribute the heat within some foods, but you need to stir from the outside of a dish toward the inside or center. If a recipe states to stir once or twice during cooking, stir at approximately even intervals. For example, in a 12-minute cooking period, if a recipe states to stir twice, stir after 4 minutes of cooking and again, after 8 minutes of cooking. However, it is not necessary to be precise. Stir only when necessary. When using lower power levels or settings, less stirring is required. Some examples of foods which may require stirring are puddings, some casseroles, some sauces, some soups, and some egg dishes. Some foods can't be stirred. These foods are rearranged or turned.

Cooking Guidelines

Some foods can't be stirred and should be **repositioned or rearranged** during cooking. Some examples include baked potatoes, cupcakes (in custard cups), and chicken pieces. Rearranging allows for more even cooking of foods. Foods which are cooked, covered or which are cooked using lower power levels, usually require little rearranging.

There are actually **two types of turning**. Turning is done when foods cannot be stirred. Foods which are cooked, covered or which are cooked at lower power levels usually require little turning.

Turning foods over: Turning foods over is done to distribute heat. Meat and poultry are two types of foods which are sometimes "turned over." Examples include roasts, turkeys and whole chickens. Small meat items such as poultry pieces may need to be turned over when in casseroles, or when in a browning skillet.

Microwave Utensils



CAUTION

To avoid burns, use protective gloves or pads when removing dishes from oven. Some utensils become hot while cooking.

Never use cooking containers or covers with any metal content. This includes all metal and enameled metal-core ware, foil, and metal-trimmed containers. Suitable heating containers include those made of paper products, glass, china, cloth, and wicker baskets.

Recommended	Not Recommended
Glass/ceramic	Aluminum foil
Natural fiber cloth	Grocery bags
Non-recycled paper	Recycled paper
Plastic	Lead crystal
Wood	Newspapers
	Metal
	Metallic trimmed china

Utensil Check Test

Use the following test to check utensils for microwave safeness.

1. Place glass measuring cup of water next to empty dish to be tested in microwave oven.
2. Heat on full power for one minute.
3. Check temperature of dish and water.
 - If dish remains cool and water is hot, dish is microwave safe.
 - If dish is slightly warm, use for short term cooking.
 - If dish is hot and water is cool, do not use. Dish remains cool if not absorbing microwaves and microwaves are being absorbed by water. Dish becomes hot if absorbing microwaves.

Cooking Hints

Cover foods for faster, more even heating. Glass lids, plastic wrap, plate covers or other paper products may be used. Do not seal. Instead, allow for steam-venting at all times.

Pierce pouches, plastic wrap covers and all foods with a thin skin or membrane, such as potatoes, squash, tomatoes, eggs, etc. This prevents an eruption in the oven and allows for expansion and/or the escape of steam.

Foods should be carefully arranged. For best results, arrange food such as vegetables or casserole-type items evenly around the edge of the plate with slightly less depth in the center. The edges of food items should not overlap or overhang the rim of the container. Cover meats with gravy or au jus and moisten all dry foods other than bread or pastry items.

Do not stack food or plated dishes in your oven.

Instead, when heating more than one serving or platters, all plates should be placed at the same level in the oven, with space between all containers.

Care and Cleaning

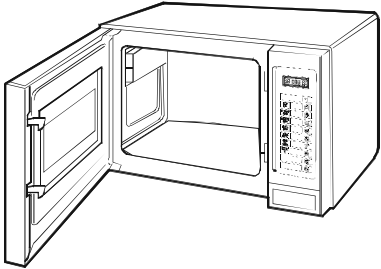
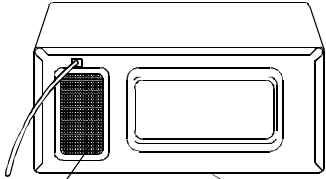
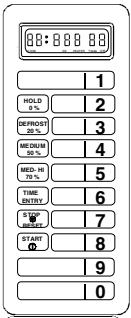
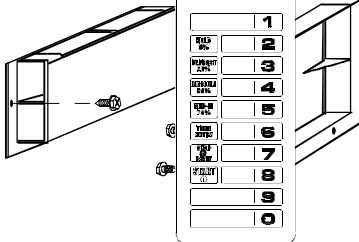
Part	Description
<p data-bbox="188 191 501 222">Interior, Exterior, and Door</p> 	<p data-bbox="647 191 1463 310">Clean microwave oven with mild detergent in warm water using soft sponge or cloth. Wring sponge or cloth to remove excess water before wiping equipment. If desired, boil a cup of water in microwave oven to loosen soil before cleaning.</p> <p data-bbox="647 365 781 396">Important:</p> <ul data-bbox="647 407 1422 548" style="list-style-type: none"> <li data-bbox="647 407 1422 468">• Do not use abrasive cleansers or cleaners containing ammonia. These could damage finish. <li data-bbox="647 478 1224 510">• Never pour water into microwave oven bottom. <li data-bbox="647 520 1263 548">• Do not use water pressure type cleaning systems.
<p data-bbox="188 564 423 596">Discharge Air Vents</p>  <p data-bbox="237 810 293 831">Intake</p> <p data-bbox="415 810 513 831">Discharge</p>	<p data-bbox="647 564 1430 653">Check monthly for a buildup of cooking vapors along intake and discharge louvers on bottom and back of oven. Clean air vents with damp cloth to ensure proper airflow. Dry thoroughly.</p>
<p data-bbox="188 873 350 905">Control Panel</p> 	<p data-bbox="647 873 1463 932">Open oven door to deactivate oven timer. Clean with mild detergent in warm water using soft sponge or cloth.</p>
<p data-bbox="188 1236 375 1268">Splatter Shields</p> 	<p data-bbox="647 1236 1446 1295">Splatter shields can be cleaned in place or removed. Clean with mild detergent in warm water using soft sponge or cloth.</p> <p data-bbox="647 1306 1438 1394">Splatter shields are held in place with (3) screws. If desired, remove splatter shields for cleaning by removing screws. Replace splatter shields before using oven.</p>

Before Calling for Service

Record all inspections and repair for future reference.



WARNING

To avoid electrical shock which can cause severe personal injury or death, do not remove outer case at any time. Only an authorized servicer should remove outer case.

Symptom	Check
If oven does not operate:	<ul style="list-style-type: none">• Check fuse or circuit breaker.• Confirm oven is plugged into dedicated circuit.• Confirm oven is on grounded and polarized circuit. Contact electrician to confirm.
If oven light does not work:	<ul style="list-style-type: none">• Oven light must be replaced by a servicer.
If oven operates intermittently:	<ul style="list-style-type: none">• Check air discharge area for obstructions.
Oven operates, but does not heat food:	<ul style="list-style-type: none">• Place one cup cool water in oven. Heat for one minute. If water temperature does not rise, oven is operating incorrectly and a servicer should be called.

Any questions or to locate an authorized servicer, call 1-866-426-2621 inside U.S.A. 1-319-622-5511 outside U.S.A. If an automated telephone system is reached, select Commercial Microwave Ovens category. Warranty service must be performed by an authorized servicer. Amana also recommends contacting an authorized servicer if service is required after warranty expires.

Appendix B

Operation—LD10D2

Heating



CAUTION

To avoid damaging oven, only heat in microwave oven when turntable is in place.



CAUTION

To avoid fire, do not dry newspapers or clothes in microwave oven.

1. Open oven door, place food in oven, and close door.
2. Set timer knob to desired cooking time by turning clockwise.
 - Turn timer knob slightly past and then back to desired cooking time for the most accurate time setting.
 - Heating begins.
3. When time has elapsed, signal sounds, and oven shuts off.

Pausing or Stopping Operation

1. Open oven door.
 - Oven stops heating.
 - Timer maintains current time setting.
2. Heating resumes when door is closed.
3. Turn timer knob counterclockwise to "OFF" to clear all cooking time.

LD10D2
1000 WATT

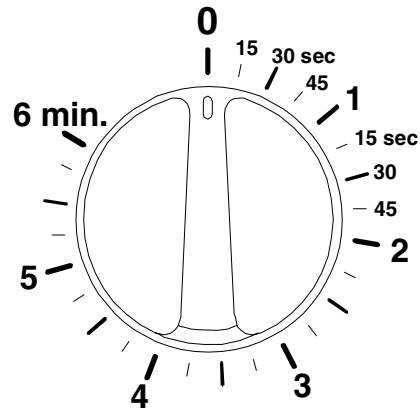

Return dial to "0" if food is removed before end of cook cycle

- * Place food in oven
- * Close door
- * Set dial to desired time
- * Remove food when bell rings

HEATING GUIDE

ITEM	TIME SETTING
1 Roll or Pastry	7-10 sec
1 Hot Dog	20-30 sec
1 Small Sandwich	30-35 sec
1 Large Sandwich	1.00-2.00
1 Bag of Popcorn (3.5 oz)	1.30-1.45
1 Burrito (Frozen)	1.30-1.45
1 Cup of Soup (Stew)	1.30-2.00
1 Casserole	1.30-2.30



Cooking Guidelines

The Amana Microwave Oven can make your job easier. You'll cook ahead and pre-portion more. You'll also spend less time preparing special-order dishes.

To be sure of consistently good results, remember a few simple guidelines.

How Microwave Ovens Heat Food

All food and liquid molecules have positive and negative particles which are in constant, but slow, motion. (Positive and negatives attract and repel each other like magnets.) In microwave cooking this molecular action is then accelerated. The instant microwaves bombard food which agitate the molecules. Agitation causes friction as molecules rub and bump into each other at an increased rate. Friction results in heat that cooks food and boils water.

Once the microwaves stop, this friction action continues by itself, eventually tapering off and returning to normal molecular action.

Microwaves penetrate food to a depth of $\frac{3}{4}$ " to $1\frac{1}{2}$ ". As cooking begins, heat is spread by conduction to the interior portion of the food just as in conventional cooking methods.

Food Variables

Microwave cooking can be directly affected by different food variables.

The **shape** of foods can greatly affect the amount of cooking time. Foods that are flat and thin heat faster than foods which are chunky. For example, a casserole will cook faster in a flat dish, rather than if heaped in a small dish. Foods cut into small pieces will cook faster than large-shaped foods. Pieces should be of a uniform size and shape for more uniform cooking, or the smaller pieces will cook faster. The greatest amount of heating takes place within $\frac{3}{4}$ " of the food's surface. The interior of large food items, or dense foods, is heated by the heat conducted from the outer food layer. The most uniform heating occurs in flat, doughnut-shaped foods. For best results, cook foods together which have similar sizes and shapes.

The **quantity** or volume of a food can affect the amount of cooking time. As the volume of the food is increased, the time required to cook or heat the item increases almost proportionately. If twice the amount of food is placed in the oven, it will take almost twice as long to cook. To determine the time for larger quantities, multiply the individual serving time by the increased amount, then reduce the total heating time by about 20%.

The **density** of foods can greatly affect the amount of cooking time. Porous foods, such as breads, cakes or pastries, will heat much more quickly than dense meats of the same size. Porous foods absorb microwaves quickly throughout. Meats absorb microwaves mostly at the exterior surface, and the interior is heated by conduction, increasing the cooking time. Meats can be cooked in a sauce, if desired. Due to the moisture content, a sauce will heat rapidly. The heat will transfer to the meat, so the meat will heat faster due to heat by conduction as well as by microwaves.

The **starting temperature** of foods affects the amount of cooking time. Each temperature degree that the food item is to raise must be supplied with a definite amount of energy. Lower initial starting temperatures require more energy and more time to cook. Therefore, refrigerator temperature foods require a longer cooking time than room temperature foods. Foods already slightly warm will heat very quickly in the oven.

The **moisture content** of foods affects the amount of cooking time. The higher the moisture content is in a food the longer the amount of cooking time.

The **fat and sugar content** of foods affects the amount of cooking time. Foods containing high fat and sugar levels heat very quickly and may reach much higher temperatures than foods having low fat and sugar levels. Foods having lower fat and sugar levels require longer cooking times.

The **arrangement** of food within a microwave oven cavity affects the way in which the food cooks. A "round" arrangement is best. Use round utensils whenever possible. Also, arrange foods such as baked potatoes in a circle, rather than in rows, for cooking. When only one food item is being cooked, place it in the center of the oven glass shelf for cooking.

Manipulation of Foods

Sometimes recipes suggest manipulating or moving food during cooking. There are several forms of manipulation:

Stirring is required less often in microwave cooking than in conventional cooking. In conventional cooking, you use a spoon to move food up from the bottom of a pan to evenly distribute the heat. In microwave cooking, you still stir to redistribute the heat within some foods, but you need to stir from the outside of a dish toward the inside or center. If a recipe states to stir once or twice during cooking, stir at approximately even intervals. For example, in a 12-minute cooking period, if a recipe states to stir twice, stir after 4 minutes of cooking and again, after 8 minutes of cooking. However, it is not necessary to be precise. Stir only when necessary. When using lower power levels or settings, less stirring is required. Some examples of foods which may require stirring are puddings, some casseroles, some sauces, some soups, and some egg dishes. Some foods can't be stirred. These foods are rearranged or turned.

Cooking Guidelines

Some foods can't be stirred and should be **repositioned or rearranged** during cooking. Some examples include baked potatoes, cupcakes (in custard cups), and chicken pieces. Rearranging allows for more even cooking of foods. Foods which are cooked, covered or which are cooked using lower power levels, usually require little rearranging.

There are actually **two types of turning**. Turning is done when foods cannot be stirred. Foods which are cooked, covered or which are cooked at lower power levels usually require little turning.

Turning foods over: Turning foods over is done to distribute heat. Meat and poultry are two types of foods which are sometimes "turned over." Examples include roasts, turkeys and whole chickens. Small meat items such as poultry pieces may need to be turned over when in casseroles, or when in a browning skillet.

Microwave Utensils



CAUTION

To avoid burns, use protective gloves or pads when removing dishes from oven. Some utensils become hot while cooking.

Never use cooking containers or covers with any metal content. This includes all metal and enameled metal-core ware, foil, and metal-trimmed containers. Suitable heating containers include those made of paper products, glass, china, cloth, and wicker baskets.

Recommended	Not Recommended
Glass/ceramic	Aluminum foil
Natural fiber cloth	Grocery bags
Non-recycled paper	Recycled paper
Plastic	Lead crystal
Wood	Newspapers
	Metal
	Metallic trimmed china

Utensil Check Test

Use the following test to check utensils for microwave safeness.

1. Place glass measuring cup of water next to empty dish to be tested in microwave oven.
2. Heat on full power for one minute.
3. Check temperature of dish and water.
 - If dish remains cool and water is hot, dish is microwave safe.
 - If dish is slightly warm, use for short term cooking.
 - If dish is hot and water is cool, do not use. Dish remains cool if not absorbing microwaves and microwaves are being absorbed by water. Dish becomes hot if absorbing microwaves.

Cooking Hints

Cover foods for faster, more even heating. Glass lids, plastic wrap, plate covers or other paper products may be used. Do not seal. Instead, allow for steamventing at all times.

Pierce pouches, plastic wrap covers and all foods with a thin skin or membrane, such as potatoes, squash, tomatoes, eggs, etc. This prevents an eruption in the oven and allows for expansion and/or the escape of steam.

Foods should be carefully arranged. For best results, arrange food such as vegetables or casserole-type items evenly around the edge of the plate with slightly less depth in the center. The edges of food items should not overlap or overhang the rim of the container. Cover meats with gravy or au jus and moisten all dry foods other than bread or pastry items.

Do not stack food or plated dishes in your oven. Instead, when heating more than one serving or platters, all plates should be placed at the same level in the oven, with space between all containers.

Care and Cleaning

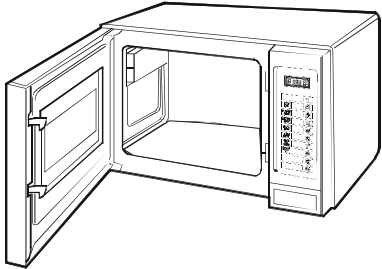
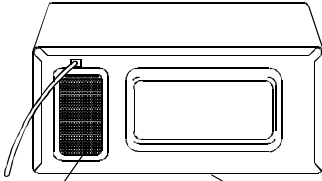
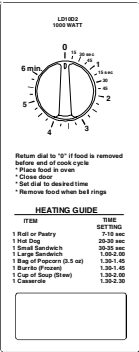
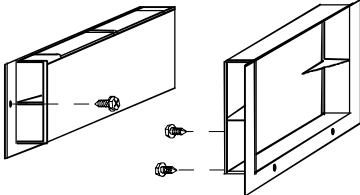
Part	Description																				
<p>Interior, Exterior, and Door</p> 	<p>Clean microwave oven with mild detergent in warm water using soft sponge or cloth. Wring sponge or cloth to remove excess water before wiping equipment. If desired, boil a cup of water in microwave oven to loosen soil before cleaning.</p> <p>Important:</p> <ul style="list-style-type: none"> • Do not use abrasive cleansers or cleaners containing ammonia. These could damage finish. • Never pour water into microwave oven bottom. • Do not use water pressure type cleaning systems. 																				
<p>Discharge Air Vents</p>  <p>Intake Discharge</p>	<p>Check monthly for a buildup of cooking vapors along intake and discharge louvers on bottom and back of oven. Clean air vents with damp cloth to ensure proper airflow. Dry thoroughly.</p>																				
<p>Control Panel</p>  <p>Return dial to "0" if food is removed before end of cook cycle. * Place food in oven. * Set dial to desired time. * Remove food when bell rings.</p> <table border="1"> <thead> <tr> <th colspan="2">HEATING GUIDE</th> </tr> <tr> <th>ITEM</th> <th>TIME</th> </tr> </thead> <tbody> <tr> <td>1 Roll or Pastry</td> <td>3:00 sec</td> </tr> <tr> <td>1 Hot Dog</td> <td>30:00 sec</td> </tr> <tr> <td>1 Small Sandwich</td> <td>30:00 sec</td> </tr> <tr> <td>1 Large Sandwich</td> <td>1:00-2:00</td> </tr> <tr> <td>1 Tray of Popcorn (3.5 oz)</td> <td>1:30-1:45</td> </tr> <tr> <td>1 Bar of Frozen</td> <td>1:30-1:45</td> </tr> <tr> <td>1 Cup of Soup (18oz)</td> <td>1:30-2:00</td> </tr> <tr> <td>1 Casserole</td> <td>1:30-2:30</td> </tr> </tbody> </table>	HEATING GUIDE		ITEM	TIME	1 Roll or Pastry	3:00 sec	1 Hot Dog	30:00 sec	1 Small Sandwich	30:00 sec	1 Large Sandwich	1:00-2:00	1 Tray of Popcorn (3.5 oz)	1:30-1:45	1 Bar of Frozen	1:30-1:45	1 Cup of Soup (18oz)	1:30-2:00	1 Casserole	1:30-2:30	<p>Open oven door to deactivate oven timer. Clean with mild detergent in warm water using soft sponge or cloth.</p>
HEATING GUIDE																					
ITEM	TIME																				
1 Roll or Pastry	3:00 sec																				
1 Hot Dog	30:00 sec																				
1 Small Sandwich	30:00 sec																				
1 Large Sandwich	1:00-2:00																				
1 Tray of Popcorn (3.5 oz)	1:30-1:45																				
1 Bar of Frozen	1:30-1:45																				
1 Cup of Soup (18oz)	1:30-2:00																				
1 Casserole	1:30-2:30																				
<p>Splatter Shields</p> 	<p>Splatter shields can be cleaned in place or removed. Clean with mild detergent in warm water using soft sponge or cloth.</p> <p>Splatter shields are held in place with (3) screws. If desired, remove splatter shields for cleaning by removing screws. Replace splatter shields before using oven.</p>																				

Before Calling for Service

Record all inspections and repair for future reference.



WARNING

To avoid electrical shock which can cause severe personal injury or death, do not remove outer case at any time. Only an authorized servicer should remove outer case.

Symptom	Check
If oven does not operate:	<ul style="list-style-type: none">• Check fuse or circuit breaker.• Confirm oven is plugged into dedicated circuit.• Confirm oven is on grounded and polarized circuit. Contact electrician to confirm.
If oven light does not work:	<ul style="list-style-type: none">• Oven light must be replaced by a servicer.
If oven operates intermittently:	<ul style="list-style-type: none">• Check air discharge area for obstructions.
Oven operates, but does not heat food:	<ul style="list-style-type: none">• Place one cup cool water in oven. Heat for one minute. If water temperature does not rise, oven is operating incorrectly and a servicer should be called.

Any questions or to locate an authorized servicer, call 1-866-426-2621 inside U.S.A. 1-319-622-5511 outside U.S.A. If an automated telephone system is reached, select Commercial Microwave Ovens category. Warranty service must be performed by an authorized servicer. Amana also recommends contacting an authorized servicer if service is required after warranty expires.