

# INSTRUCTION SHEET

# 16200129

Description: Magnetron Kit # 59004013 and 59001997

Contents: 1 – Magnetron  
1 – 16200129 Instruction Sheet

1. Magnetron included in this kit may be larger than the original magnetron. When using the new magnetron remove 2 foam pads from front and 2 foam pads from rear duct for the magnetron you are replacing, upper or lower, as shown below. Adjust air duct fins to accommodate replacement magnetron.

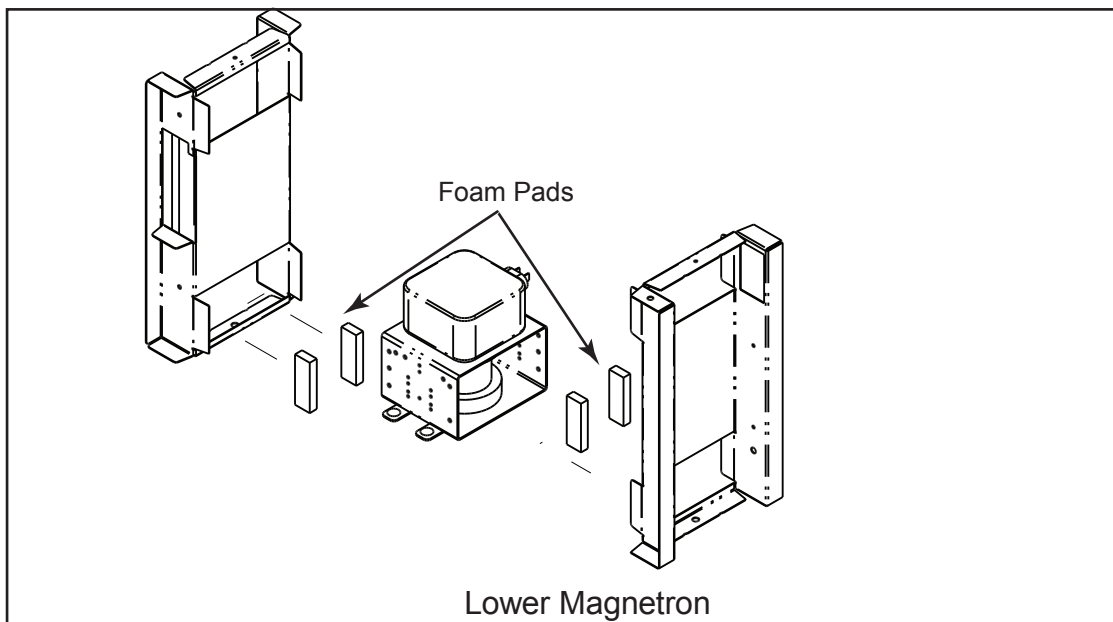
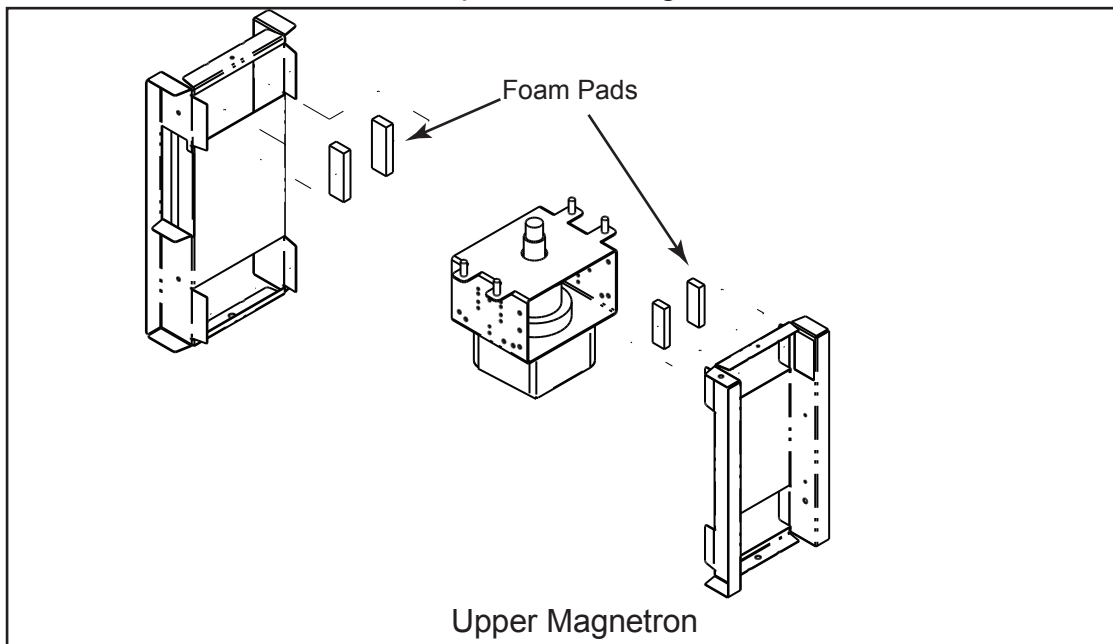

2. If application requires magnetron with no studs, use the following procedure to remove magnetron mounting studs.
  - a. Place magnetron mounting stud over a socket slightly larger than the size of the mounting stud on the edge of a sturdy work surface (Figure 1).
  - b. Use a hammer to knock the mounting stud into the socket taking care not to bend the magnetron mounting ears (Figure 2, Figure 3).
  - c. Repeat on all remaining magnetron mounting studs.

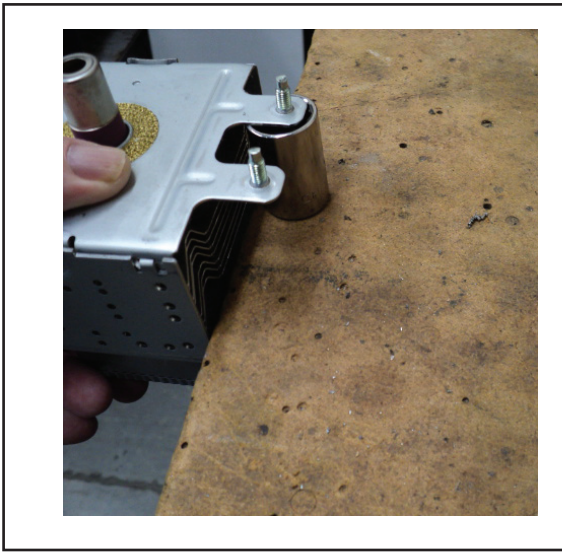

Figure 1

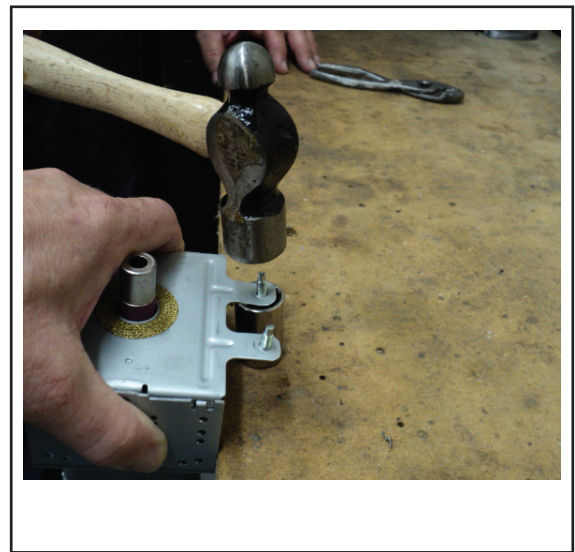

Figure 2



Figure 3