

Service

This manual is to be used by qualified appliance technicians only. Maytag does not assume any responsibility for property damage or personal injury for improper service procedures done by an unqualified person.

International Countertop Commercial Microwave Ovens

This Base Manual covers general information.

Refer to individual Technical Sheet for information on specific models.

This manual includes, but is not limited to the following:

LD510D	P1329704M
LD510P	P1329705M
DEL10D	P1329706M
DEL10E	P1329707M

Important Information

Important Notices for Servicers and Consumers

Maytag will not be responsible for personal injury or property damage from improper service procedures. Pride and workmanship go into every product to provide our customers with quality products. It is possible, however, that during its lifetime a product may require service. Products should be serviced only by a qualified service technician who is familiar with the safety procedures required in the repair and who is equipped with the proper tools, parts, testing instruments and the appropriate service information. **IT IS THE TECHNICIANS RESPONSIBILITY TO REVIEW ALL APPROPRIATE SERVICE INFORMATION BEFORE BEGINNING REPAIRS.**



WARNING

To avoid risk of severe personal injury or death, disconnect power before working/servicing on appliance to avoid electrical shock.

To locate an authorized servicer, please consult your telephone book or the dealer from whom you purchased this product. For further assistance, please contact:

Customer Service Support Center

CAIR Center

Web Site	Telephone Number
WWW.AMANA.COM	1-800-843-0304
WWW.JENNAIR.COM	1-800-536-6247
WWW.MAYTAG.COM	1-800-688-9900
CAIR Center in Canada	1-800-688-2002
Amana Canada Product	1-866-587-2002

Recognize Safety Symbols, Words, and Labels



DANGER

DANGER—Immediate hazards which **WILL** result in severe personal injury or death.



WARNING

WARNING—Hazards or unsafe practices which **COULD** result in severe personal injury or death.



CAUTION

CAUTION—Hazards or unsafe practices which **COULD** result in minor personal injury, product or property damage.

Table of Contents

Important Information	2	Disassembly Procedures	
Important Safety Information	4-8	Disconnecting Wire Terminals	21
General Information		Door Assembly	21
Placement of the Oven	9	Door Disassembly	22
Radio Interference	9	Outer Case	22
Earthing Instructions	9	Control Panel	22
Microwave Oven Features	10	Controller Removal (Electronic Models).....	23
Troubleshooting Procedures	11-16	Key Pad Removal	23
Component Testing Procedures	17	Timer Removal (Dial Models)	23
Microwave Power Test Procedures		Interlock Switches	24
Power Test (Traditional Test Method)	19	High Voltage Capacitor	24
Microwave Leakage Testing		Diode	25
Equipment	20	Transformer	25
Procedure For Measuring Radiation Leakage	20	Fuse Block / Filter Assembly	25
Measurement With the Outer Panel Removed	20	Fuse	25
Measurement With a Fully Assembled Oven	20	Magnetron	25
Record Keeping and Notification After Measurement	20	Fan Motor	26
		Cavity Thermostat	26
		Light Socket / Bulb Assembly	26
		Stirrer Motor	26

Important Safety Information

PRECAUTIONS TO AVOID POSSIBLE EXPOSURE TO EXCESSIVE MICROWAVE ENERGY

- (a) **DO NOT** attempt to operate this oven with the door open since open-door operation can result in harmful exposure to microwave energy. It is important not to defeat or tamper with the safety interlocks.
- (b) **DO NOT** place any object between the oven front face and the door or allow soil or cleaner residue to accumulate on sealing surfaces.
- (c) **DO NOT** operate the oven if it is damaged. It is particularly important that the oven door close properly and that there is no damage to the: (a) Door (bent), (b) hinges and latches (broken or loosened), (c) door seals and sealing surfaces.
- (d) The oven should **NOT** be adjusted or repaired by anyone except properly qualified service personnel.

PRECAUTIONS A PRENDRE POUR EVITER LES RISQUES D'EXPOSITION A DES QUANTITES EXCESSIVES D'ENERGIE MICRO-ONDE

- (a) **NE PAS** essayer de faire marcher le four avec la porte ouverte car cela risque d'exposer l'utilisateur à une quantité nocive d'énergie micro-onde. Ne jamais supprimer ou altérer les verrouillages de sécurité.
- (b) **NE RIEN METTRE** entre la face avant du four et la porte et ne pas laisser de saletés ou de produits de nettoyage s'accumuler sur les surfaces d'étanchéité.
- (c) **NE JAMAIS** faire fonctionner le four s'il est endommagé. Il est tout particulièrement important que la porte du four se ferme correctement et que les éléments suivants fonctionnent sans problème : a) la porte (faussée), b) les charnières et les verrouillages (cassés ou desserrés), c) les joints et les surfaces d'étanchéité de la porte.
- (d) Le four **NE DOIT ETRE** réparé que par des réparateurs qualifiés.

PRECAUCIONES PARA EVITAR LA POSIBLE EXPOSICION EXCESIVA A LA ENERGIA DE MICROONDAS

- (a) **NO** intente hacer funcionar este horno con la puerta abierta ya que podría resultar en una exposición dañina a la energía de microondas. Es muy importante no pasar por alto o averiar los interruptores de seguridad.
- (b) **NO** coloque ningún objeto entre el frente del horno y la puerta. Tampoco permita que suciedad o residuos de limpiador se acumulen en las superficies de sellado del aparato.
- (c) **NO** haga funcionar el horno si éste estuviera averiado. Es de particular importancia que la puerta del horno se cierre correctamente y que no existan daños en: (a) la puerta (dobladuras), (b) las bisagras y el pestillo (rotos o flojos), (c) los sellos de las puertas y otras superficies de sellado.
- (d) El horno **NO** deberá ser ajustado o reparado por ninguna persona excepto personal de servicio propiamente calificado.

VORSICHTSMASSNAHMEN ZUM SCHUTZ GEGEN MIKROWELLENSTRAHLUNG

- (a) **NICHT** versuchen, den Herd mit offener Tür zu betreiben, da Sie dadurch schädlicher Mikrowellenstrahlung ausgesetzt werden können. Auf keinen Fall die Sicherheitsverriegelung unwirksam machen oder ändern.
- (b) **KEINE** Gegenstände zwischen Herd und Tür einklemmen oder Schmutz und Rückstände von Reinigungsmitteln auf den Dichtflächen sich ansammeln lassen.
- (c) **KEINEN** beschädigten Herd benutzen. Es ist besonders wichtig, daß die Herdtür richtig schließt und die folgenden Teile nicht beschädigt sind: (a) Tür (z.B. verbogen), (b) Scharniere und Klinken (z.B. gebrochen oder lose), (c) Türdichtungen und Dichtflächen.
- (d) Das Gerät **NUR** von qualifiziertem Kundendienstpersonal reparieren lassen.

Important Safety Information

VAROITUS MIKROAALTOSÄTEILYÄ

Käyttäjä ei saa joutua alttiiksi mikroaaltoenergialle, jota voi säteillä magnetronista tai muusta mikroaaltoja kehittävästä laitteesta, jos sitä käytetään väärin tai jos se kytketään väärin. Kaikkien mikroaaltoliitännöiden sekä syöttöettä ulostulopuolella, aaltoputkien laippojen ja tiivisteiden tulee

olla varmistettuja. Mikroaaltouunia ei saa koskaan käyttää ilman kuormaa, jossa mikroaaltoenergiaa kuluu. Avoimeen aaltoputkeen tai antenniin ei saa koskaan katsoa virran ollessa kytkettynä.

VARNING FÖR MIKROVÅGSSTRÅLNING

Mikrovågsenergi kan stråla från magnetronen eller från annan mikrovågsgenererande anordning om den används eller ansluts felaktigt. Alla anslutningar för mikrovåg, såsom flänsar och tätningar måste vara betryggande ur säkerhets-

synpunkt. Starta aldrig anordningen utan mikrovågsabsorberande belastning. Mikrovågsstrålning från en öppen vågledare eller antenn har sådan strålningstäthet att uppenbar skaderisk föreligger.

ADVARSEL FOR MIKROBØLGESTRALING

Mikrobølgeenergi kan stråle fra magnetronen eller annen mikrobølgeproduserende anordning ved feilkopling eller feil bruk. Alle mikrobølgeinntak og -uttaksforbindelser, flenser og pakninger, må være sikkerhetsmessig betryggende

utført. Anordningen må aldri startes uten mikrobølgeabsorberende belastning. Se aldri inn mot en åpen bølgeleder eller antenne mens apparatet er i drift.

FORSIGTIG MIKROBØLGESTRÅLING

Undgå at blive udsat for stråling fra mikrobølgegeneratoren eller andre dele som fører mikrobølgeenergi.

Important Safety Information

PRECAUZIONI PER EVITARE L'EVENTUALE ECCESSIVA ESPOSIZIONE ALLE MICROONDE

- (a) **NON** cercare di far funzionare questo forno con lo sportello aperto: ciò può causare l'esposizione nociva alle microonde. È importante non danneggiare o manomettere i dispositivi di sicurezza.
- (b) **NON** porre alcun oggetto fra il lato anteriore del forno e lo sportello o permettere il depositarsi di sporcizia o residui sulle superfici di tenuta.
- (c) **NON** usare un forno danneggiato. È molto importante che lo sportello del forno si chiuda bene e che non vi siano danni a: (a) sportello (piegato); (b) cardini e dispositivi di chiusura (rotti o allentati); (c) guarnizioni dello sportello e delle superfici di tenuta.
- (d) Il forno va regolato o riparato **ESCLUSIVAMENTE** da personale d'assistenza debitamente qualificato.

VOORZORGSMATREGELEN TER VOORKOMING VAN MOGELIJKE BLOOTSTELLING AAN OVERMATIGE MICROGOLFENERGIE

- (a) Probeer **NIET** om deze magnetron met de deur open te gebruiken. daar gebruik met open deur schadelijke blootstelling aan microgolffenergie ten gevolge kan hebben. Het is belangrijk dat u de veiligheidssluitingen nooit onklaar maakt of ermee knoeit.
- (b) Plaats **GEEN** voorwerpen tussen de voorkant van de oven en de deur. Zorg dat geen vuil of schoonmaakmiddel op de sluitvlakken achterblijft.
- (c) Gebruik de magnetron **NIET** indien hij beschadigd is. Het is vooral belangrijk dat de deur goed sluit en dat er geen beschadigingen zijn aan: (a) de deur (verbogen), (b) de scharnieren en sloten (gebroken of los), (c) de deurdichtingen en sluitvlakken.
- (d) De magnetron mag **UITSLUITEND** door daartoe bevoegd servicepersoneel bijgesteld en gerepareerd worden.

Important Safety Information



CAUTION

Read the following information to avoid possible exposure to microwave radiation:

The basic design of the Amana or Menumaster microwave ovens make it an inherently safe device to both user and servicer. However, there are some precautions which should be followed when servicing the microwave oven to maintain this safety. These are as follows:

1. Always operate the unit from an adequately earthed outlet. Do not operate on a two-wire extension cord.
2. Before servicing the unit (if unit is operable), perform the microwave leakage test.
3. The oven should never be operated if the door does not fit properly against the seal, the hinges or hinge bearings are damaged or broken; the choke is damaged, (pieces missing, etc.); or any other visible damage can be noted. Check the choke area to ensure that this area is clean and free of all foreign matter.
4. If the oven operates with the door open and produces microwave energy, take the following steps.
 - A. Tell the user not to operate the oven.
 - B. Contact Maytag immediately.
5. Always have the oven disconnected when the outer case is removed except when making the "live" tests called for in this Service Manual. Do not reach into the equipment area while the unit is energized. Make all connections for the test and check them for tightness before plugging the cord into the outlet.
6. Always earth the capacitors on the magnetron filter box and H. V. Capacitor with an insulated-handle screwdriver before working in the high voltage area of the equipment compartment. Some types of failures will leave a charge in these capacitors and the discharge could cause a reflex action which could make you injure yourself.
7. In the area of the transformer, capacitor, diode, and magnetron there is HIGH VOLTAGE. When the unit is operating, keep this area clean and free of anything which could possibly cause an arc or earthing, etc.
8. Do not for any reason defeat the interlock switches. There is no valid reason for this action at any time; nor will it be condoned by Maytag.
9. IMPORTANT: Before returning a microwave to a customer, check for proper switch interlock action. The primary and secondary switches MUST open when the door is actuated. The monitor switch MUST close at a $\frac{1}{64}$ -inch (0.5 mm) when the door is opened.
10. Before returning a microwave to a customer, verify the door spacing is reasonably uniform along the top, bottom, and sides, and that it measures $\frac{1}{64}$ -inch (0.5 mm) or less.
11. The Amana or Menumaster microwave oven should never be operated with:
 - Any components removed and/or bypassed.
 - Any of the safety interlocks found to be defective.
 - Any of the seal surfaces defective, missing, or damaged.
12. To ensure that the unit does not emit excessive microwave leakage and to meet the Department of Health Human Service guidelines, check the oven for microwave leakage using Narda Model 8110 B, Holaday HI1501, HI1510, or HI1710 leakage monitor as outlined in the instructions. The maximum leakage level allowed is $4\text{mW}/\text{cm}^2$.
13. If servicer encounters an emission reading over $4\text{mw}/\text{cm}^2$ the servicer is to cease repair and contact the Amana Service Department immediately for further direction. Amana Appliances will contact the proper Government Agency upon verification of the test results.

Important Safety Information



WARNING

Precautions to be observed before and during servicing to avoid possible exposure to excessive microwave energy, or electrical shock disconnect power to oven.

- (A) Do not operate or allow oven to be operated with door open.
- (B) Make the following safety checks on all ovens to be serviced before activating the magnetron or other microwave source, and make repairs as necessary:
 - Interlock operation
 - Proper door closing
 - Seal and sealing surfaces (arcing, wear, and other damage)
 - Damage to or loosening of hinges and latches
 - Evidence of dropping or abuse
- (C) Before turning on microwave power for any service test or inspection within the microwave generating compartments, check the magnetron, waveguide or transmission line, and cavity for proper alignment, integrity, and connections.
- (D) Any defective or misadjusted components in the interlock, monitor, door seal, and microwave generation and transmission systems shall be repaired, replaced or adjusted by procedures described in this manual before oven is released to the consumer.
- (E) Check microwave leakage to verify compliance with the federal performance standard should be performed on each oven prior to release to the consumer.

Wiring

Good service practice is to never route wiring over terminals and/or sharp edges. This applies to any wiring without regard to the circuit voltage. Wire insulation material and thickness is designed and regulated for electrical spacing purpose only, but cannot always be relied upon because of possible cuts and/or abrasions, which can occur during servicing.



WARNING

To avoid risk of electrical shock, personal injury or death, make sure these earthing instructions are followed.

Earthing Instructions



WARNING

Do not remove earthing prong when installing earthed appliance in a home or business that does not have three wire earthing receptacle, under no condition is earthing prong to be cut off or removed. It is the personal responsibility of the consumer to contact a qualified electrician and have properly earthed three prong wall receptacle installed in accordance with appropriate electrical codes

Should a two prong adapter plug be required temporarily, it is the personal responsibility of the consumer to have it replaced with properly earthed three prong receptacle or the two prong adapter properly earthed by a qualified electrician in accordance with appropriate electrical codes.

Servicing of Earthed Products

The standard accepted color coding for earthing wires is GREEN or GREEN WITH YELLOW STRIPE. These earth leads are NOT to be used as current carrying conductors. It is extremely important that the technician replace any and all earths prior to completion of the service call. Under no condition should earth wire be left off causing a potential hazard to technicians and consumer.

General Information

Placement of the Oven

Do not install microwave next to or above source of heat, such as a deep fat fryer. This could cause the microwave to operate improperly and could shorten the life of electrical components.

Install microwave on a level countertop surface.

Do not block or obstruct oven filter. Allow access for cleaning.

All air vents must be kept clear during cooking. If air vents are covered during operation the oven may overheat. In this case, a sensitive thermal safety device automatically turns the oven off. The oven will be inoperable until the oven has cooled sufficiently.

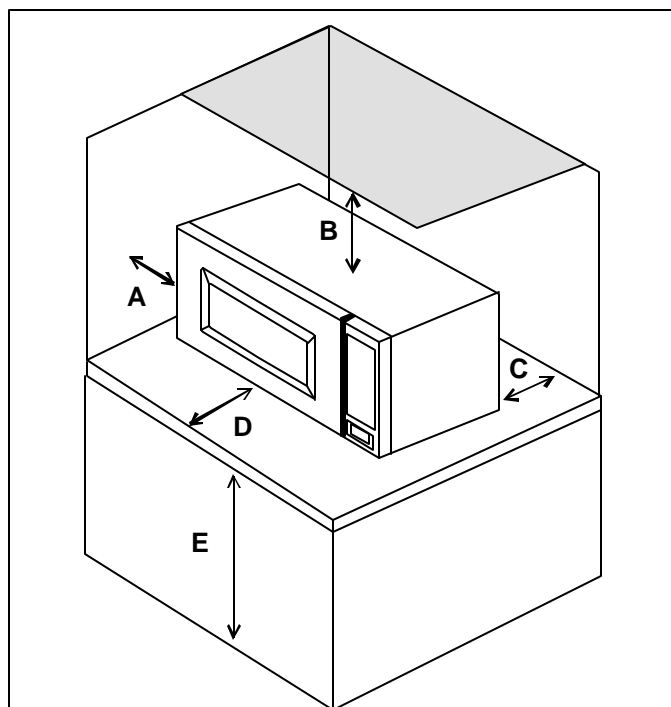

- A—The sides of the oven should have at least enough clearance to allow air flow for ventilation.
- B—Allow at least 30 cm (11-¹³/₁₆") of clearance around top unit.
- C—Allow at least 10 cm (4") of clearance and sides of unit.
- D—Allow at least 8 cm (3") inches from door front to edge of countertop, to avoid accidental tipping of the unit.
- E—Place oven on a level surface a minimum of 85 cm (33-¹/₂") above the floor.

Radio Interference

Microwave oven operation may cause interference to radio, television, or similar equipment. Reduce or eliminate interference by doing the following:

- Clean the door and sealing surfaces of microwave oven according to instructions in "Care and Cleaning" section.
- Place radio, television, etc. as far as possible from the microwave oven.
- Use a properly installed antenna on radio, television, etc. to obtain stronger signal reception.

Earthing Instructions

This appliance **MUST** be earthed. If an electrical short circuit occurs, earthing reduces the risk of electric shock by providing an escape wire for the electric current. The cord for this appliance has a earthing wire with a earthing plug. Place the plug into an outlet that is properly installed and earthed. Do not use a two-prong adapter.

WARNING

To avoid risk of electric shock, personal injury or death, do not alter the plug and use earthing plug properly.

Consult a qualified electrician if you do not understand the earthing instructions or if you wonder whether the appliance is properly earthed.

Keep the electrical power cord dry and do not pinch or crush it in anyway.

The wires in the power cord are colored in accordance with the following code:

- **Green/Yellow:** **Earth**
- **Blue:** **Neutral**
- **Brown:** **Live**

General Information

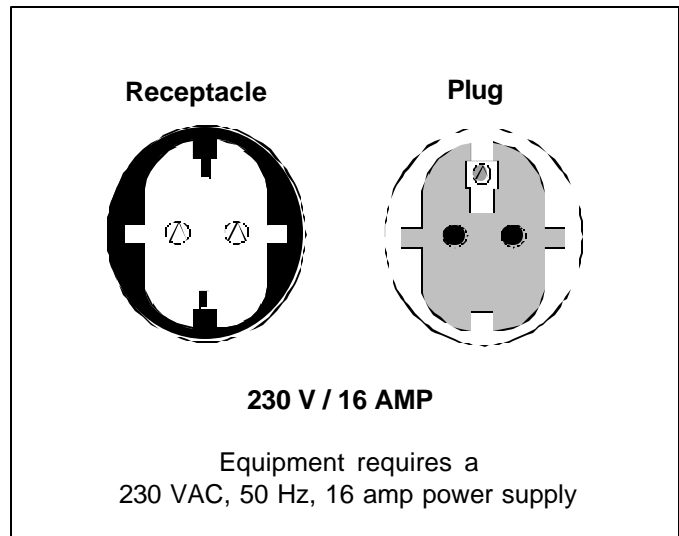
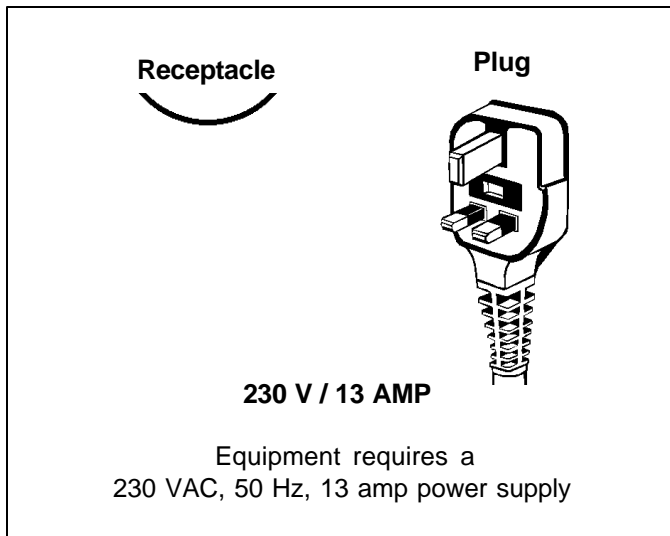

Do not use an extension cord. If the product power cord is too short, have a qualified electrician install a three-prong receptacle. This unit should be plugged into a separate 230 VAC / 50 Hz power supply. If other equipment is on the same circuit, an increase in cooking times may be required and a fuse can be blown.

Microwave Oven Description

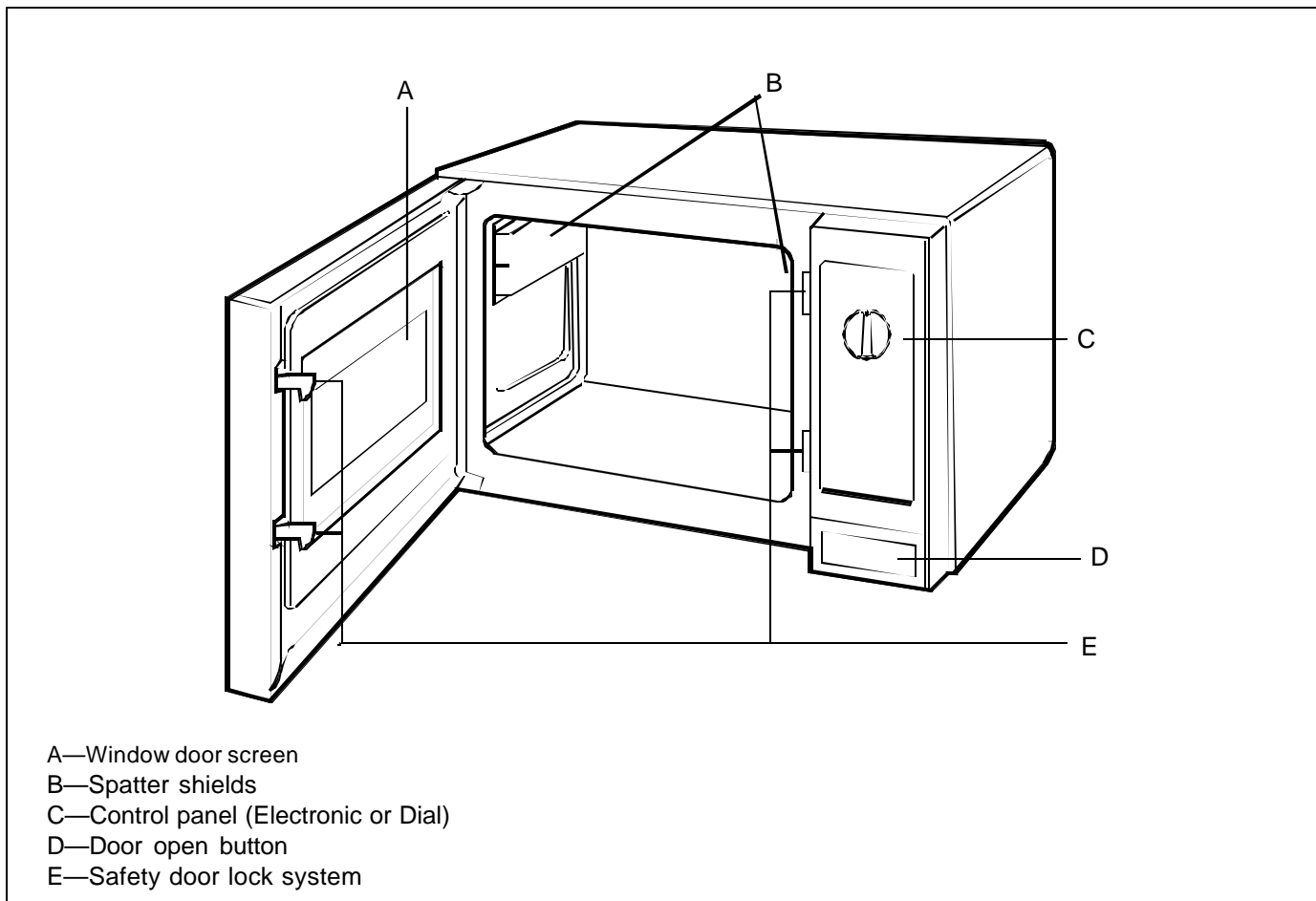

Troubleshooting Procedures

When you get a complaint from customers, evaluate the complaint carefully. If the following symptoms apply, instruct the customer in the proper use of the microwave oven. This can eliminate an unnecessary service call.



CAUTION

- Verify proper earthing before checking for trouble.
- Be careful of the high voltage circuit.
- Discharge the high voltage capacitor.
- When checking the continuity of the switches or of the high voltage transformer, disconnect one lead wire from these parts and then check continuity with the AC plug removed. To do otherwise may result in a false reading or damage to your meter.
- Do not touch any part of the circuit on the controller, since static electric discharge may damage the control panel. Always touch yourself to earth while working on this panel to discharge any static charge built up in your body.

Condition	Cause	Remedy
Microwave oven does not work.	<ul style="list-style-type: none"> • Inserting multiple plugs into one outlet and using them at the same time (blown fuse or breaker). • Microwave oven plug is not inserted tightly. 	<ul style="list-style-type: none"> • Avoid using other electrical appliances when you use the microwave oven. • Insert microwave oven plug securely.
Output power is too low.	<ul style="list-style-type: none"> • Low AC input voltage. • Food temperature is too low. 	<ul style="list-style-type: none"> • Use the microwave oven at adequate line voltage. • This may not be a defect. It is possible that the food should be cooked for a longer time period.
Sparks occur.	<ul style="list-style-type: none"> • Using metallic ware and allowing it to touch the oven wall. • Ceramic ware trimmed in gold or silver is used. 	<ul style="list-style-type: none"> • Do not use metallic ware for cooking. • Do not use any type of cookware with metallic trimming.
Uneven cooking.	Inconsistent food thickness, inconsistent fat or moisture distribution within the food products.	<ul style="list-style-type: none"> • Use plastic wrap or lid. • Stir once or twice while cooking soup, cocoa, milk, etc.

Troubleshooting Procedures

Trouble 1: The following visual conditions indicate a probable failed control circuit.

1. Incomplete segments.
 - Segment missing.
 - Partial segment missing.
 - Digit flickering (Note: Slight flickering is normal.)
2. Colon does not turn on or blink.
3. A distinct change in the brightness of one or more numbers in display.
4. One or more digits in the display are not lighting.
5. Display indicates a number different from one touched, for example, key in 5 and 3 appears in the display.
6. Specific numbers (for example 7 or 9) will not display when key pad is touched.
7. Display does not count down with time blinking or up with clock operation.
8. Display obviously jumps in time while counting down.
9. Display counts down too fast while cooking.
10. Each indicator light does not turn on after setting cooking cycle.
11. Display time of day does not reappear when cooking is finished.

Condition	Check	Result	Cause	Remedy
No input can be programmed.	Check the connection between keypad and controller.	<ul style="list-style-type: none"> • Continuity • No continuity 	<ul style="list-style-type: none"> • Failed controller. • Loose connection. 	<ul style="list-style-type: none"> • Replace controller. • Repair connection.
<ol style="list-style-type: none"> 1. Some inputs cannot be programmed. 2. Display shows a number or figure different from one touched. 3. Random programming when touching other pads. 4. Display is fixed at some figure and can not accept any input. 	Replace keypad and check operation.	<ul style="list-style-type: none"> • Everything works as specified. • Still have trouble. 	<ul style="list-style-type: none"> • Failed keypad. • Failed controller. 	<ul style="list-style-type: none"> • Replace keypad. • Replace controller.

Troubleshooting Procedures (Electronic Models)

Trouble 2: Oven does not operate at all, display window does not display any digits, and no input is accepted.

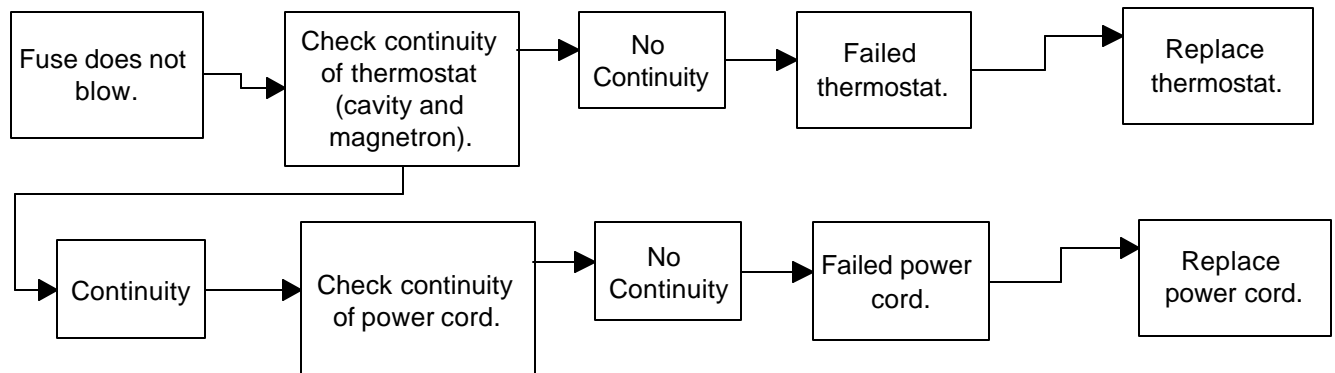
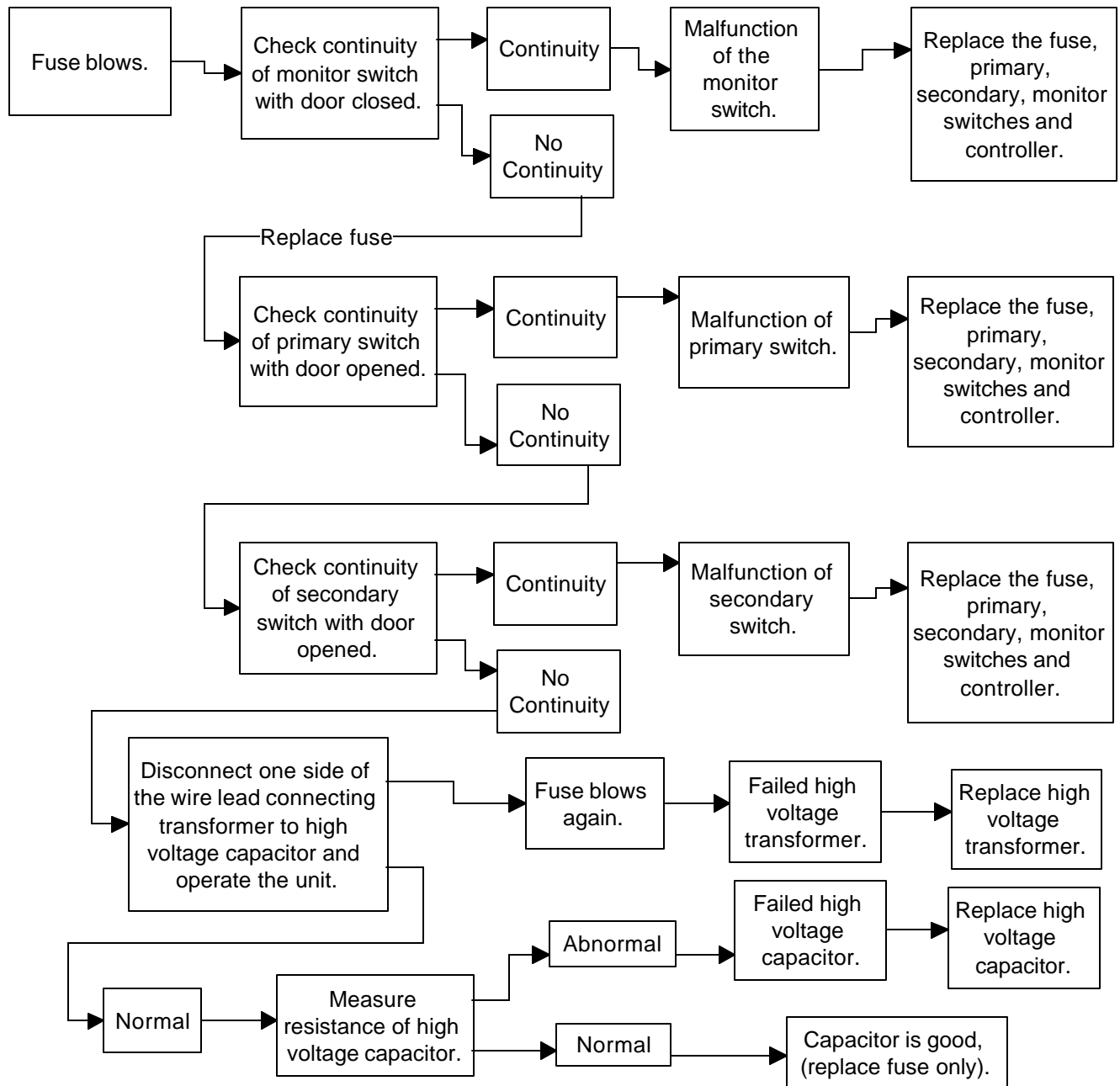

Troubleshooting Procedures (Electronic Models)

Trouble 3: Display shows all digits programmed, but does not start cooking when the START pad is pressed.

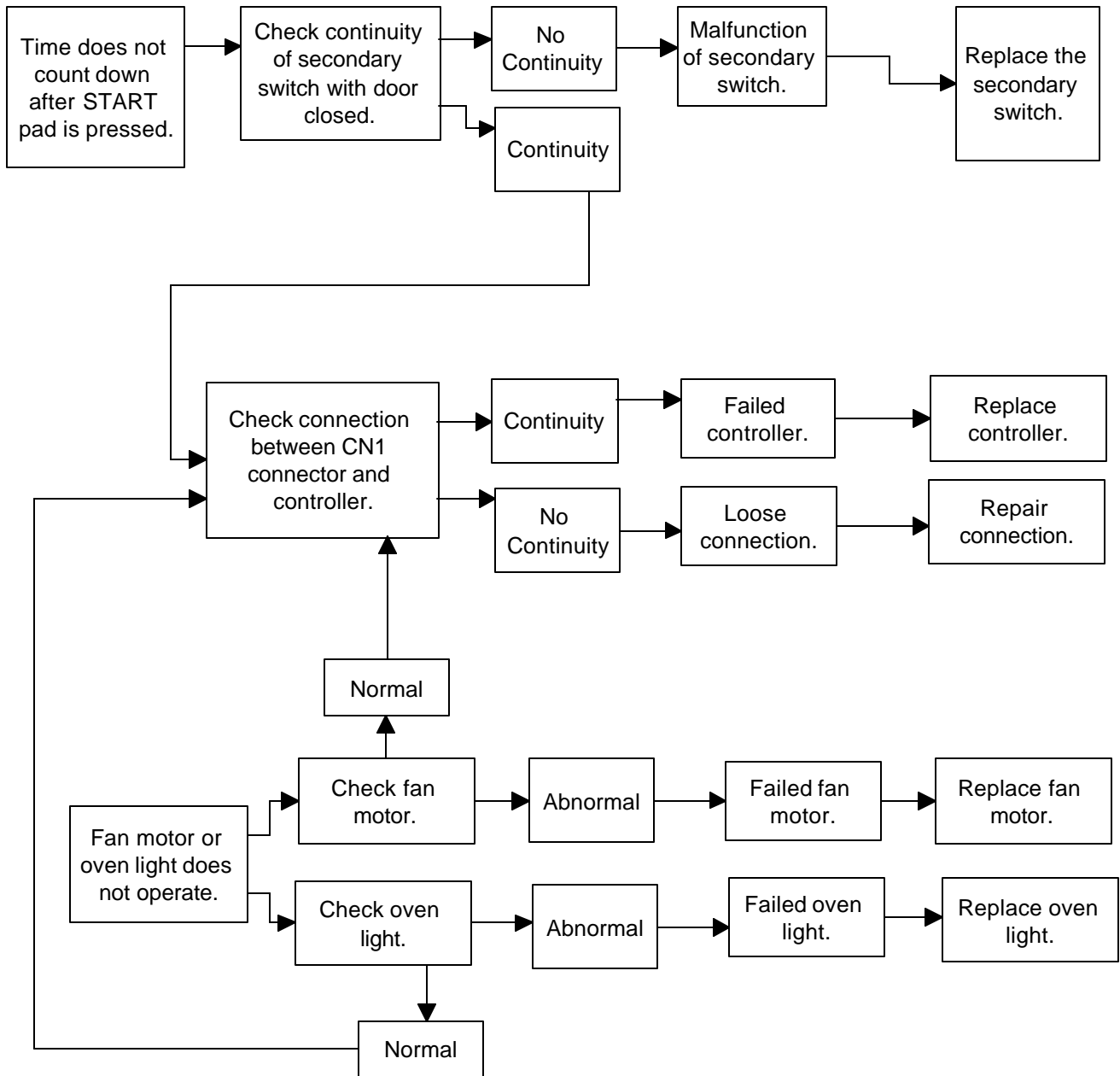

Troubleshooting Procedures (Electronic Models)

Trouble 4: Oven operates with little or no heat.

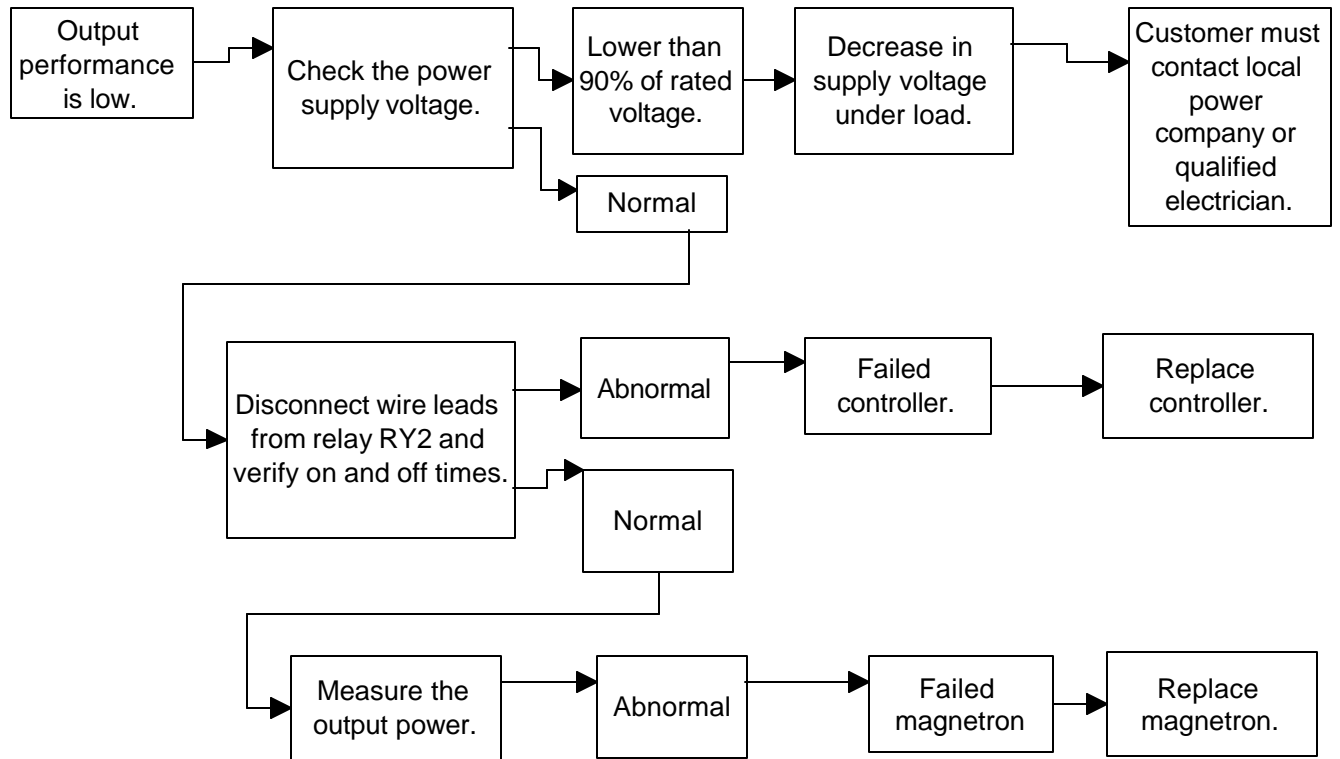

NOTE: Simple test of power output can be conducted by heating one liter of water for one minute. Refer to Amana Power Test on page 14 of this manual.

Troubleshooting Procedures (Electronic Models)

Trouble 5: No microwave oscillation even when oven light and fan motor operate.

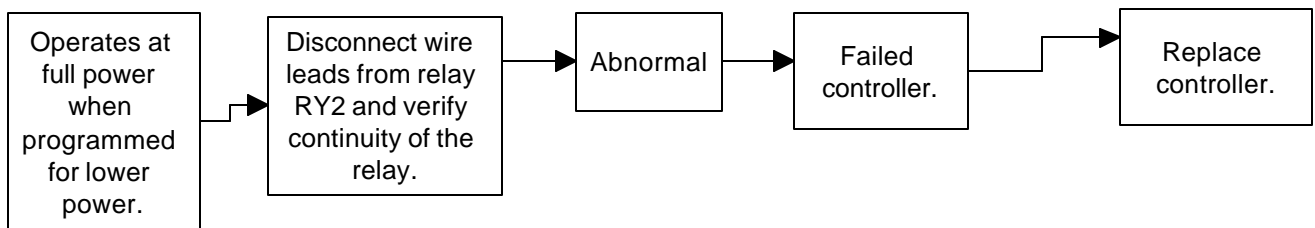
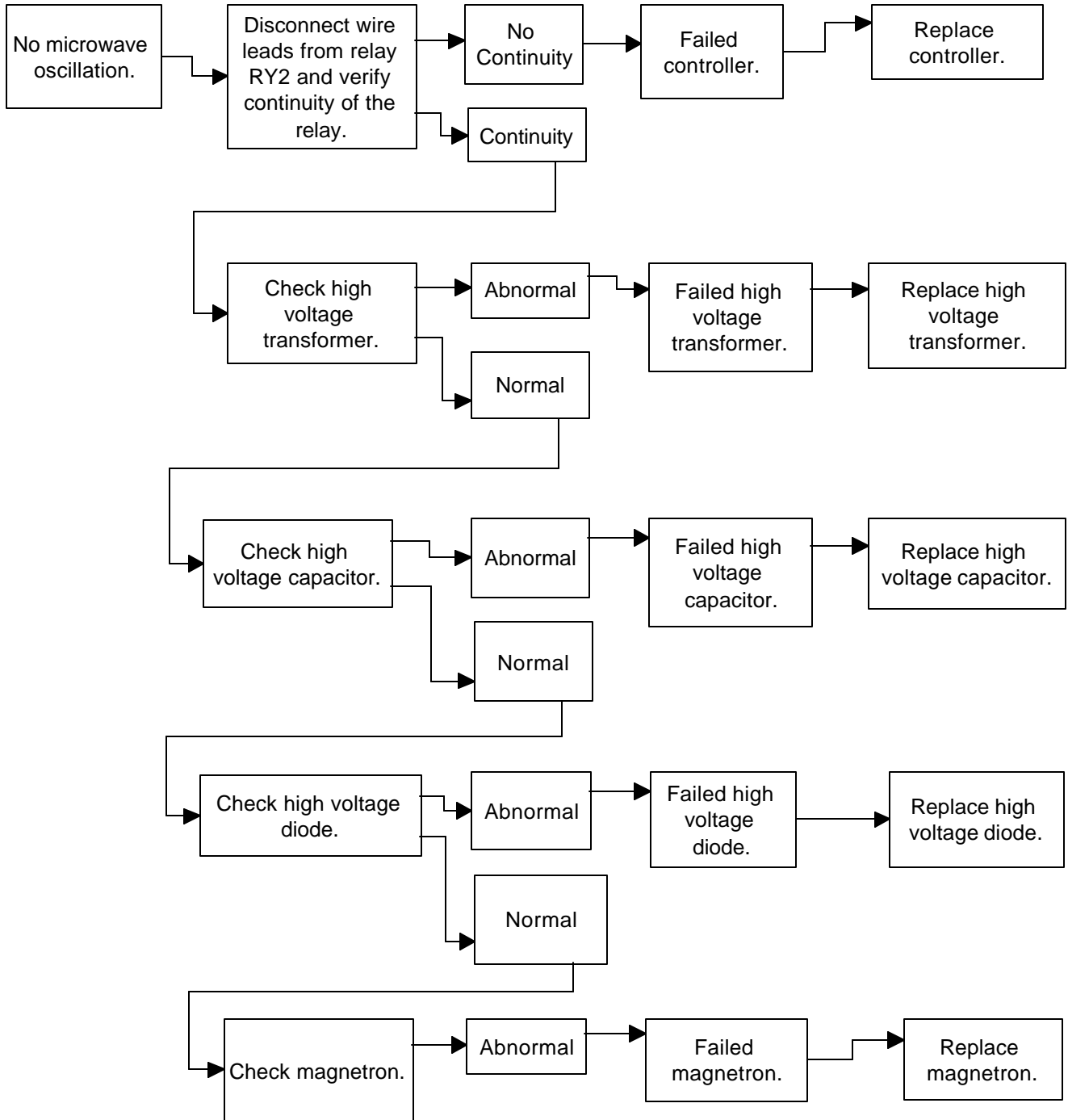



Component Testing Procedures

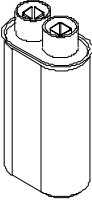

WARNING

To avoid risk of electrical shock, personal injury, or death, disconnect power to oven and discharge capacitor before servicing, unless testing requires it.

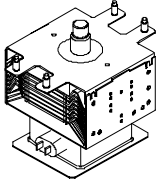
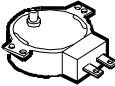
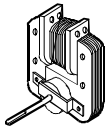
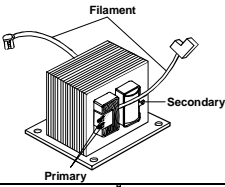
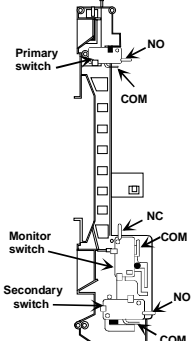
Illustration	Component	Test	Results
	Thermal cutout	Disconnect all wires from TCO. Measure resistance across terminals. Magnetron TCO Cavity TCO	Open at (145°C) 293°F and closed at (85°C) 185°F Opens at (110°C) 230°F
	Capacitor	Discharge Capacitors Remove wires from capacitor terminals and connect ohmmeter, set on highest resistance scale to terminals. Also check between each terminal and capacitor case.	Between Terminals: Meter should momentarily deflect towards zero then return to over 5 MΩ. If no deflection occurs, or if continuous deflection occurs, replace capacitor. Terminal to Case: Infinite resistance
	Diode assembly	Discharge Capacitors Remove diode lead from capacitor and connect ohmmeter. Reverse leads for second test.	Infinite resistance should be measured in one direction and 50KΩ or more in the opposite direction. NOTE: Analog meter must contain a battery of 6 volts minimum.
	Magnetron	Discharge Capacitors Remove wires from magnetron and connect ohmmeter to terminals. Also check between each terminal and ground.	Between Terminals: Less than 1 Ω Each terminal to ground measures infinite resistance. Note: This test is not conclusive. If oven does not heat and all other components test good replace the magnetron and re-test.
	Turntable motor	Remove all wires from terminals. Measure resistance from: Terminal to terminal	Approximately 12–14 KΩ
	Fan motor	Remove all wires from motor. Measure resistance across coil.	Approximately 350–450 Ω
	Transformer	Discharge Capacitors Remove all wires from terminals. Measure resistance from: Primary Secondary to transformer base plate..... Filament	Approximately 1.4 – 2.2 Ω Approximately 90 - 110 Ω <1 Ω
	Interlock switches	Disconnect wires to switch With door open measure resistance from: COM to N.O.—Primary COM to N.C.—Monitor..... COM to N.O.—Secondary With door closed measure resistance from: COM to N.O.—Primary COM to N.C.—Monitor..... COM to N.O.—Secondary	Infinite Ω 0 Ω Infinite Ω 0 Ω Infinite Ω 0 Ω

Component Testing Procedures

⚠ WARNING

To avoid risk of electrical shock, personal injury, or death, disconnect power to oven and discharge capacitor before servicing, unless testing requires it.

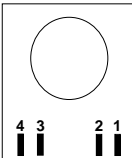
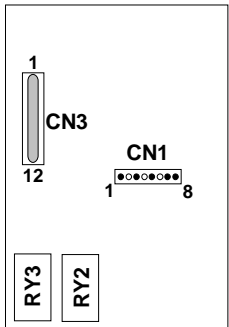
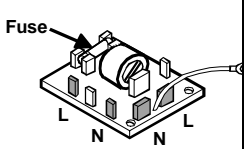
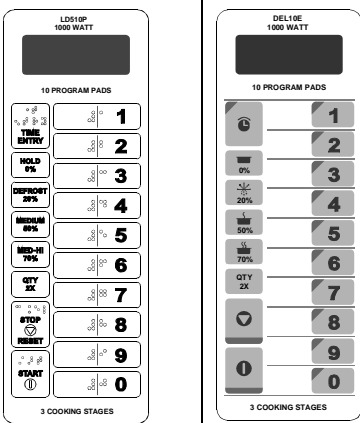
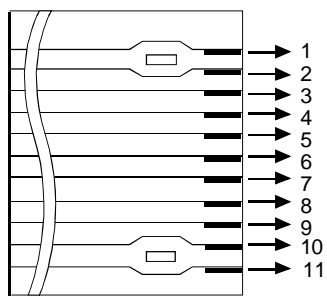
Illustration	Component	Test	Results																																																									
	Timer 7 minute	Disconnect wire from terminals. Measure resistance of the following terminals: Terminal 3 to terminal 4 (timer motor) Terminal 1 to terminal 2 (timer switch)	Approximately 22 K Ω Timer OFF— infinite Ω Timer ON— < 1 Ω																																																									
	Control	CN1 Pin 1 (black) to Pin 3 (white) RY2 (Cook Relay) Unplug oven and remove wire leads from RY2 terminals. Connect ohm-meter leads to terminals. Plug oven into power supply Initiate cook cycle NOTE: RY2 should cycle when using reduced power levels. RY3 (Fan Relay) Unplug oven and remove wire leads from RY3 terminals. Connect ohm-meter leads to terminals. Plug oven into power supply Initiate cook cycle NOTE: Fan relay remains energized for 60 seconds following cook cycle.	Line voltage input to control transformer. Infinite Ω < 1 Ω Power levels for Relay 2 <table border="1" style="width: 100%; border-collapse: collapse;"> <thead> <tr> <th>Power Level</th> <th>Cycles On for:</th> <th>Cycles Off for:</th> </tr> </thead> <tbody> <tr> <td>20%</td> <td>6 sec</td> <td>16 sec</td> </tr> <tr> <td>40%</td> <td>10 sec</td> <td>12 sec</td> </tr> <tr> <td>60%</td> <td>14 sec</td> <td>8 sec</td> </tr> <tr> <td>80%</td> <td>18 sec</td> <td>4 sec</td> </tr> <tr> <td>100%</td> <td>22 sec</td> <td>0 sec</td> </tr> </tbody> </table> Infinite Ω < 1 Ω	Power Level	Cycles On for:	Cycles Off for:	20%	6 sec	16 sec	40%	10 sec	12 sec	60%	14 sec	8 sec	80%	18 sec	4 sec	100%	22 sec	0 sec																																							
Power Level	Cycles On for:	Cycles Off for:																																																										
20%	6 sec	16 sec																																																										
40%	10 sec	12 sec																																																										
60%	14 sec	8 sec																																																										
80%	18 sec	4 sec																																																										
100%	22 sec	0 sec																																																										
	Fuse block / Filter board	Disconnect wire from terminals. Measure resistance of the following terminals: Verify fuse is good Terminal L to L Terminal N to N	< 1 Ω < 1 Ω < 1 Ω																																																									
	Touch panel	Continuity is indicated as 100 Ω and below. Each pad must be pressed to perform the following test. <div style="text-align: center;">  </div>	<table border="1" style="width: 100%; border-collapse: collapse;"> <thead> <tr> <th>Pad</th> <th>Trace</th> <th>Measurement</th> </tr> </thead> <tbody> <tr><td>1</td><td>2 & 8</td><td>Continuity</td></tr> <tr><td>2</td><td>3 & 8</td><td>Continuity</td></tr> <tr><td>3</td><td>4 & 8</td><td>Continuity</td></tr> <tr><td>4</td><td>5 & 8</td><td>Continuity</td></tr> <tr><td>5</td><td>6 & 8</td><td>Continuity</td></tr> <tr><td>6</td><td>7 & 8</td><td>Continuity</td></tr> <tr><td>7</td><td>1 & 9</td><td>Continuity</td></tr> <tr><td>8</td><td>2 & 9</td><td>Continuity</td></tr> <tr><td>9</td><td>3 & 9</td><td>Continuity</td></tr> <tr><td>0</td><td>1 & 8</td><td>Continuity</td></tr> <tr><td>Hold</td><td>1 & 10</td><td>Continuity</td></tr> <tr><td>Defrost</td><td>2 & 10</td><td>Continuity</td></tr> <tr><td>Medium</td><td>3 & 10</td><td>Continuity</td></tr> <tr><td>MED-HI</td><td>4 & 10</td><td>Continuity</td></tr> <tr><td>Time Entry</td><td>5 & 10</td><td>Continuity</td></tr> <tr><td>Stop/Reset</td><td>6 & 10</td><td>Continuity</td></tr> <tr><td>Start</td><td>7 & 10</td><td>Continuity</td></tr> <tr><td>X2</td><td>7 & 9</td><td>Continuity</td></tr> </tbody> </table>	Pad	Trace	Measurement	1	2 & 8	Continuity	2	3 & 8	Continuity	3	4 & 8	Continuity	4	5 & 8	Continuity	5	6 & 8	Continuity	6	7 & 8	Continuity	7	1 & 9	Continuity	8	2 & 9	Continuity	9	3 & 9	Continuity	0	1 & 8	Continuity	Hold	1 & 10	Continuity	Defrost	2 & 10	Continuity	Medium	3 & 10	Continuity	MED-HI	4 & 10	Continuity	Time Entry	5 & 10	Continuity	Stop/Reset	6 & 10	Continuity	Start	7 & 10	Continuity	X2	7 & 9	Continuity
Pad	Trace	Measurement																																																										
1	2 & 8	Continuity																																																										
2	3 & 8	Continuity																																																										
3	4 & 8	Continuity																																																										
4	5 & 8	Continuity																																																										
5	6 & 8	Continuity																																																										
6	7 & 8	Continuity																																																										
7	1 & 9	Continuity																																																										
8	2 & 9	Continuity																																																										
9	3 & 9	Continuity																																																										
0	1 & 8	Continuity																																																										
Hold	1 & 10	Continuity																																																										
Defrost	2 & 10	Continuity																																																										
Medium	3 & 10	Continuity																																																										
MED-HI	4 & 10	Continuity																																																										
Time Entry	5 & 10	Continuity																																																										
Stop/Reset	6 & 10	Continuity																																																										
Start	7 & 10	Continuity																																																										
X2	7 & 9	Continuity																																																										

Microwave Power Test Procedures



WARNING

To avoid risk of electrical shock, personal injury, or death, disconnect power to oven and discharge capacitor before servicing, unless testing requires it.

Power Test (Traditional Test Method)

Test equipment required is Amana power test kit R0157397 (Fahrenheit), or Menumaster power test kit M95D5 (Celsius).

1. Fill the plastic container to the 1000 ml. line with cool tap water.
2. Using the thermometer; stir the water, measure, and record the water temperature.

Initial water temperature should be approximately 60°F (16°C).

3. Place container on the center of the oven shelf and heat the water for **33 seconds for ovens with more than 1550 watts or 63 seconds for ovens with less than 1550 watts.**

NOTE: Use a watch second hand, not the oven timer.

4. Stir the water, measure and record the temperature of the water after heating time is complete.
5. Subtract the starting water temperature (Step 2), from the ending water temperature (Step 4) to obtain the temperature rise (ΔT).
6. See the Traditional Power Test Temperature Chart below.

NOTES: •The IEC-705 test method requires precision measurements and equipment. It is not practical to perform the IEC test in the field. To convert the traditional power test results to the approximate IEC-705 rating, take the traditional power test results and add 100 watts per magnetron for the unit being tested.

Example: 840 — watts output using the traditional power test for model LD510P
 + 100 — watts (1 magnetrons X 100 watts)
 940 — Approximate IEC-705 results

- Always perform power test three times for accuracy, changing the water after each test is performed.
- Variation or errors in the test procedure will cause a variance in the temperature rise. Additional power tests should be made if temperature rise appears marginal.
- Low line voltage will cause lower temperature rise.

Temperature Chart

SIXTY–THREE SECONDS run time chart for units less than 1550 Watts cooking power

ΔT (°F)	Cooking Power Output	ΔT (°F)	Cooking Power Output	ΔT (°C)	Cooking Power Output	ΔT (°C)	Cooking Power Output
12	464	27	1046	7	490	15	1050
13	504	28	1085	8	560	16	1120
14	542	29	1124	9	630	17	1190
15	581	30	1162	10	700	18	1260
16	620	31	1201	11	770	19	1330
17	659	32	1240	12	840	20	1400
18	697	33	1279	13	910	21	1470
19	736	34	1317	14	980		
20	775	35	1359				
21	814	36	1395				
22	852	37	1434				
23	891	38	1472				
24	930	39	1511				
25	969	40	1550				
26	1007						

Microwave Leakage Testing



WARNING

To avoid risk of electrical shock, personal injury, or death, disconnect power to oven and discharge capacitor before servicing, unless testing requires it.



WARNING

Check for radiation leakage after servicing. Should the leakage be more than 4mW/cm² inform Maytag immediately. After repairing or replacing any radiation safety device, keep a written record for future reference, as required by D.H.H.S. and HEW regulations. This requirement must be strictly observed. In addition, the leakage reading must be recorded on the service repair ticket while in the customer's home.

Equipment

- Electromagnetic radiation monitor
- 600 cc glass beaker

Procedure For Measuring Radiation Leakage

Note before measuring -

- Do not exceed meter full scale deflection. Leak monitor should initially be set to the highest scale.
 - To prevent false readings the test probe should be held by the grip portion of the handle only.
 - The scan speed is equal to one inch per antenna revolution or one inch per second if antenna speed is unknown.
 - Areas to be checked are all door seal areas and any venting parts.
 - Leakage with the outer panel removed ...4mW/cm² or less.
 - Leakage for fully assembled oven with door normally closed ...4mW/cm² or less.
 - Leakage for a fully assembly oven (before the latch switch (primary) is interrupted) while pulling the door ... 4mW/cm² or less.
1. Pour 275 cc ±15 cc (9 oz ±1/2 oz) of 20°C ± 5°C (68°F ± 9°F) water in a beaker which is graduated to 600 cc and place the beaker in the center of oven.
 2. Set the radiation monitor to 2450 MHz and use it following the manufacturer's recommended test procedure to assure correct results.
 3. While measuring the leakage, always use the two inch (5 cm) spacer supplied with the probe.
 4. Press the start pad or turn on the timer and with the magnetron oscillating, measure the leakage by holding the probe perpendicular to the surface being measured.

Measurement With the Outer Panel Removed



DANGER

Avoid contacting any high voltage components.

Whenever you replace the magnetron, measure for radiation leakage before the outer panel is installed and after all necessary components are replaced or adjusted. Special care should be taken in measuring around the magnetron.

Measurement With a Fully Assembled Oven

After all components including the outer panel are fully assembled, measure for radiation leakage around the door periphery, the door viewing window, the exhaust opening, and air inlet openings.

Record Keeping and Notification After Measurement

1. After any adjustment or repair to a microwave oven, a leakage reading must be taken. Record this leakage reading on the repair ticket even if it is zero.
2. A copy of the repair ticket and the microwave leakage reading should be kept by the repair facility.

Disassembly Procedures

WARNING

High voltage is present at the high voltage terminal of the high voltage transformer during any cooking cycle.

It is neither necessary or advisable to attempt measurement of the high voltage circuitry.

Before touching any oven components or wiring, always unplug the oven from its power source and discharge the capacitor.

Disconnecting Wire Terminals

All wire terminals are locking-type terminals. Proceed as follows to disconnect wire terminals:

Insulated terminals:

Grasp insulator pod and pull back.

DO NOT PULL ON WIRE.

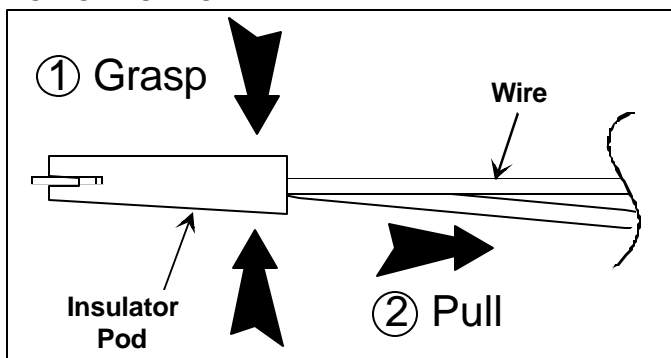

Non-insulated terminals:

Use a small blade screwdriver to depress locking-tab and pull on terminal.

DO NOT PULL ON WIRE.

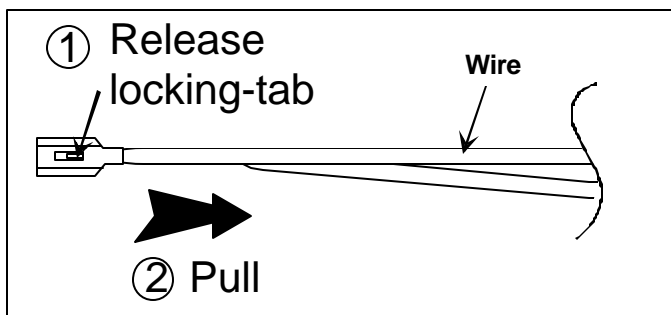

To avoid the risk of electrical shock, personal injury, or death, disconnect power to oven and discharge capacitors before following any disassembly procedure.

Door Assembly

CAUTION

A microwave leakage test must be performed anytime a door assembly is removed, replaced, disassembled, or adjusted for any reason.

Door Removal

1. Disconnect power to oven.
2. Open oven door, remove top hinge cap, and slowly lift door to disengage the hinge pins at top and bottom.

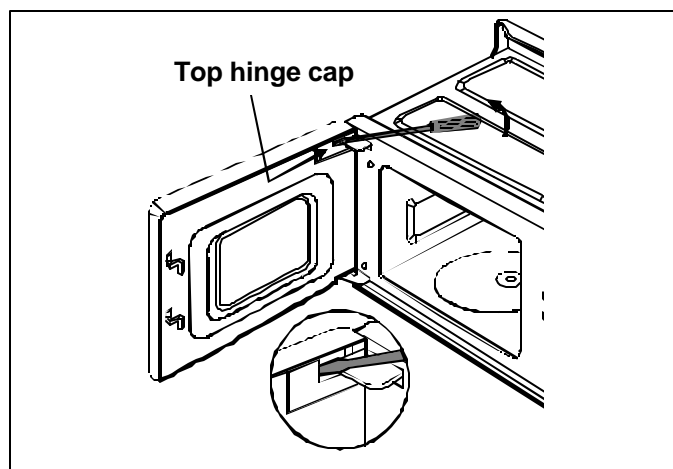

3. To re-install door, place bottom pin into slot first, then align top pin.
4. Replace top hinge cap.

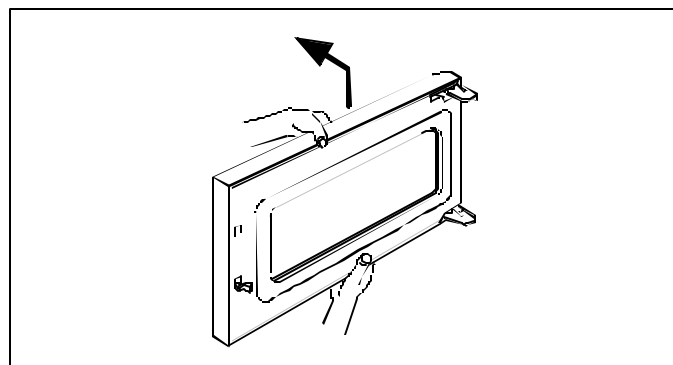

Disassembly Procedures



WARNING

To avoid the risk of electrical shock, personal injury, or death, disconnect power to oven and discharge capacitors before following any disassembly procedure.

Door Disassembly

1. Disconnect power to oven.
2. Remove oven door, (see "Door Removal").
3. Begin at the bottom of the door near hinge, insert flat blade screwdriver between choke cover and outer door panel. Gently pry upward on choke cover to release tabs. Work in clockwise direction to remove choke cover.



CAUTION

To avoid property damage, care must be taken when prying choke cover from oven door.

4. Slide latch assembly upward and pull away from door frame to release tabs from frame.
5. Disconnect latch spring from door frame.
6. Begin at hinge side of door near bottom, insert flat blade screwdriver between door frame/choke assembly and outer door panel. Gently pry outer door panel away from door frame to release tabs. Work in clockwise direction to remove door frame.
7. Reassemble in reverse order.

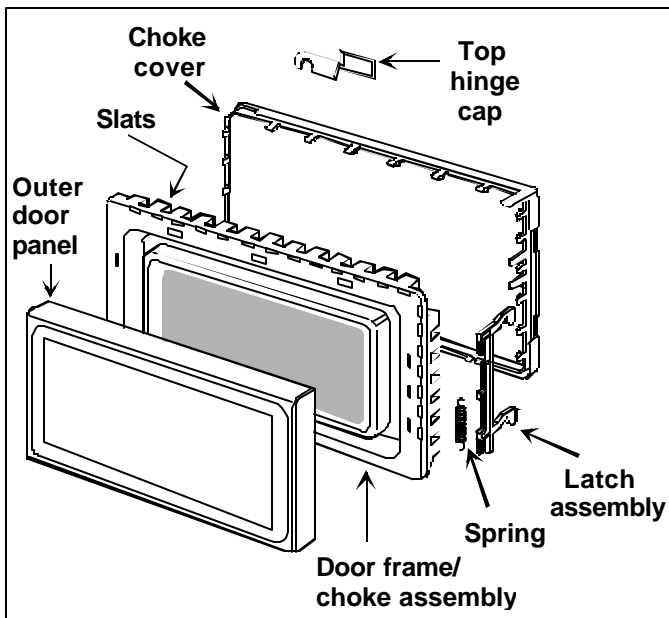

CAUTION

A microwave leakage test must be performed anytime a door assembly is removed, replaced, disassembly, or adjusted for any reason.

NOTE: When disassembling door, use caution to prevent deformation of slats on door frame/choke assembly.

Outer Case

1. Disconnect power to oven.
2. Remove screws securing outer case to unit.
3. Slide outer case towards rear of unit.
4. Reassemble in reverse order.

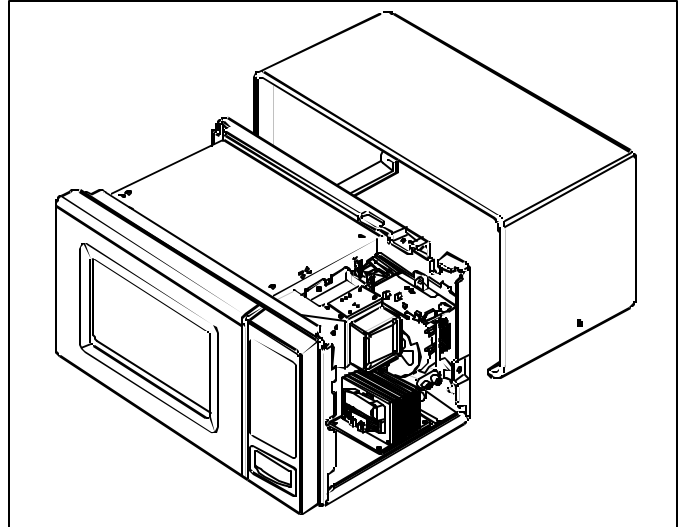

Control Panel Removal

1. Disconnect power to oven and remove outer case, (see "Outer Case" procedure).
2. Disconnect and label wires from controller/timer.
3. Open oven door.
4. Remove screw securing top of control panel to cavity. Lift control panel up and out to release bottom tabs.

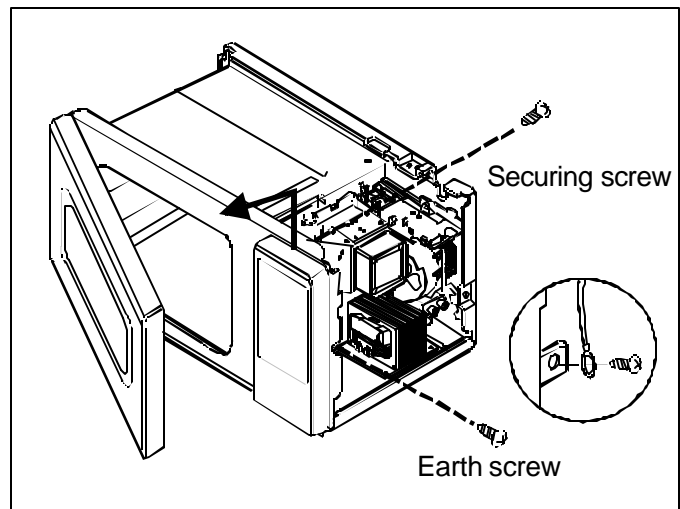

5. Reassemble in reverse order.

NOTE: Be sure to re-install earth wire when securing control panel to cavity.

Disassembly Procedures



To avoid the risk of electrical shock, personal injury, or death, disconnect power to oven and discharge capacitors before following any disassembly procedure.

Controller Removal (Electronic Models)

1. Disconnect power to oven and remove outer case, (see "Outer Case" procedure).
2. Remove control panel, (see "Control Panel" section).
3. Disconnect keypad ribbon connector .

NOTE: Caution should be used when removing ribbon from connector. Ribbon cable has two holes to align and lock ribbon to connector.

4. Remove screws securing controller to control panel assembly.

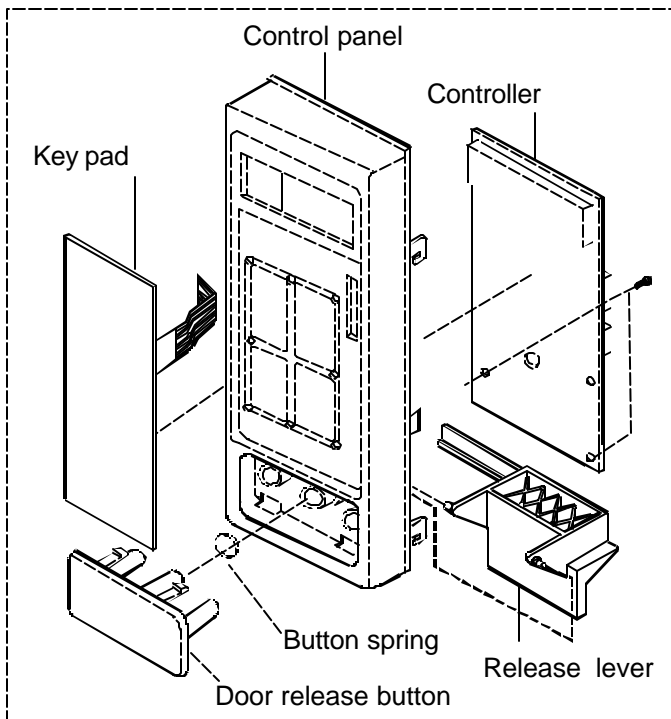

5. Reassemble in reverse order.

NOTE: Do not flex controller.

Key Pad Removal

1. Disconnect power to oven and remove outer case, (see "Outer Case" procedure).
2. Remove control panel, (see "Control Panel" section).
3. Disconnect ribbon connector.
4. Peel off failed key pad from control panel.
6. Reassemble in reverse order.

Timer Removal (Dial Models)

1. Disconnect power to oven and remove outer case (see "Outer Case" procedure).
2. Remove control panel, (see "Control Panel" section).
3. Remove screws securing timer to control panel.
4. Remove knob from timer.
5. Reassemble in reverse order.

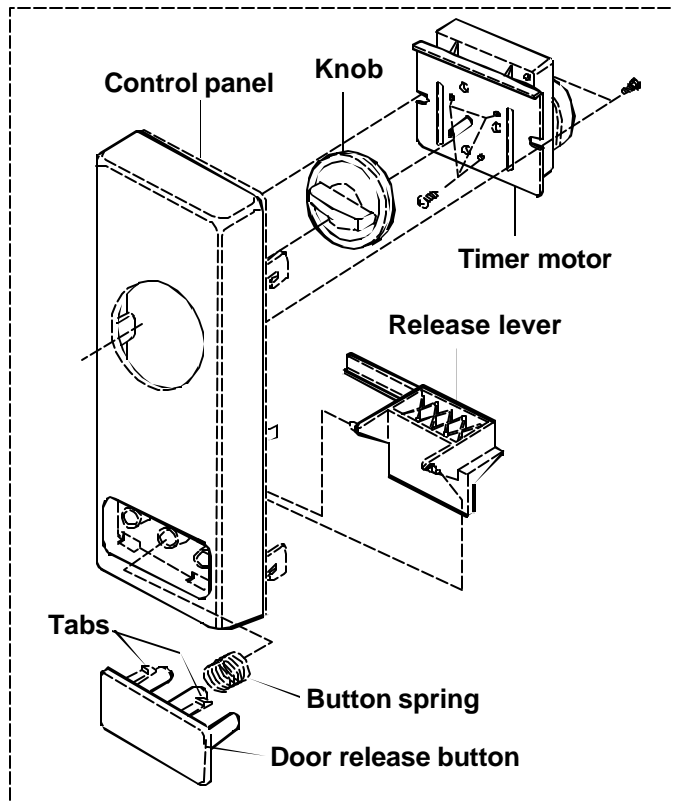

All Models

Door Release Lever / Release Button / Spring

1. Disconnect power to oven and remove outer case (see "Outer Case" procedure).
2. Carefully pry tab on control panel to disengage release lever from control panel.
3. Push (4) tabs on door release button and remove button from control panel.
4. Remove spring from door release button.
5. Reassemble in reverse order.

Disassembly Procedures



WARNING

To avoid the risk of electrical shock, personal injury, or death, disconnect power to oven and discharge capacitors before following any disassembly procedure.

Interlock Switches

Primary switch is operated by top latch arm.

Interlock Switch Removal

1. Disconnect power to oven and remove outer case, (see "Outer Case" procedure).
2. Remove control panel, (see "Control Panel" section).
3. Test interlock switches before removing, (see testing procedures).
4. Disconnect and label wire connections.
5. Remove switches by carefully releasing locking tabs on switch bracket and tilting switches to remove from switch bracket.

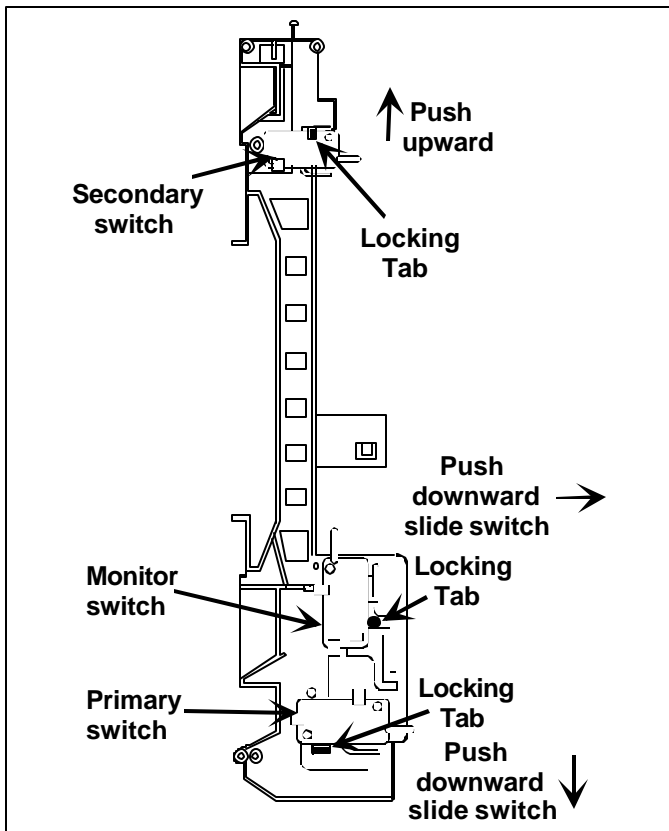

NOTE: After repairing the door or the interlock system, it is necessary to check the switch continuity before operating the oven.



CAUTION

Before replacing a blown monitor fuse, test the primary interlock switch, secondary interlock switch, monitor switch, and power relay contacts for proper operation. If the monitor fuse is blown by a failed switch operation, all switches and controller must be replaced.

Adjusting Interlocks

The interlock monitor, primary, and secondary switches act as a final safety switch, protecting the operator from microwave energy. After adjusting the interlock switch assembly, verify wires are correctly connected.

For door fit and switch operation, switch bracket is adjustable.

1. Disconnect power to oven and remove outer case, (see "Outer Case" procedure).
2. Loosen switch bracket mounting screws.
3. Close oven door, move switch bracket toward rear of oven until door gap is less than $\frac{1}{64}$ -inch (0.5 mm).
4. Hold switch bracket securely for proper switch operation and door fit, retighten screws.
5. Open oven door slowly, watching the switches. Verify switches release in the following order.
 - Primary interlock switch
 - Secondary interlock switch
 - Interlock monitor switch

NOTE: Adjust the switch bracket until all switches operate in proper sequence.

6. Close the oven door slowly, watching the switches. Verify switches activate in the following order.
 - Interlock monitor switch
 - Secondary interlock switch
 - Primary interlock switch
7. When proper switch sequence has been achieved, tighten the switch bracket securely.



CAUTION

A microwave leakage test must be performed anytime a door assembly is removed, replaced, disassembled, or adjustment of switch bracket is made.

High Voltage Capacitor

High voltage capacitor should always be discharged by shorting a terminal to a chassis earth. The capacitor has a internal "shunt" resistor, but the mechanical discharge should always be performed to avoid personal injury.

High Voltage Capacitor Removal

1. Disconnect power to oven and remove outer case, (see "Outer Case" procedure).
2. Discharge high voltage capacitor.
3. Remove and label wire leads from capacitor terminals.
4. Push the end of capacitor straps towards rear of oven to release strap from fan shroud.
5. Slide capacitor out of slots and remove capacitor.
6. Reassemble in reverse order.

Disassembly Procedures



To avoid the risk of electrical shock, personal injury, or death, disconnect power to oven and discharge capacitors before following any disassembly procedure.

Diode

1. Disconnect power to oven and remove outer case, (see "Outer Case" procedure).
2. Discharge high voltage capacitor, (see "High Voltage Capacitor" section).
3. Disconnect diode from high voltage capacitor and remove screw securing diode to earth.
4. Reassemble in reverse order.

Transformer

1. Disconnect power to oven and remove outer case, (see "Outer Case" procedure).
2. Discharge high voltage capacitor, (see "High Voltage Capacitor" section).
3. Disconnect and label wire leads from transformer.
4. Remove screws securing transformer and remove.
5. Reassemble in reverse order.

Fuse Block / Filter Assembly

1. Disconnect power to oven and remove outer case, (see "Outer Case" section).
2. Disconnect and label wires.
3. Carefully lift rear of fuse block assembly to release assembly from locating pin.
4. Slide fuse block assembly towards front of oven to remove.
5. Reassemble in reverse order.

Fuse

Fuse Removal

Fuse is located on the noise filter board.

1. Disconnect power to oven and remove outer case, (see "Outer Case" section).
2. Remove and replace fuse, reassemble in reverse order.



Before replacing a blown monitor fuse, test the primary interlock switch, secondary interlock switch, monitor switch, and power relay contacts for proper operation. If the monitor fuse is blown by a failed switch operation, all switches and controller must be replaced.

Magnetron

Magnetron is mounted on the side of the cavity.

1. Disconnect power to oven and remove outer case, (see "Outer Case" section).
2. Discharge high voltage capacitor, (see "High Voltage Capacitor" section).
3. Remove filter assembly from magnetron terminals.
4. Remove air duct.
5. Remove screws securing magnetron to the wave guide.

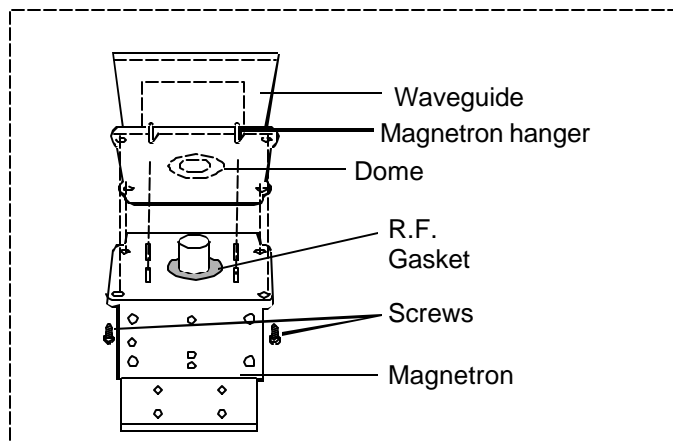

6. Reassemble in reverse order.

NOTE: When replacing magnetron, make sure gasket is in correct position and in good condition.



During replacement of magnetron, be certain the R.F. anode gasket is in place around the anode stud.



A microwave leakage test must be performed anytime a magnetron assembly is removed, replaced, disassembled, or adjusted for any reason.

Disassembly Procedures



To avoid the risk of electrical shock, personal injury, or death, disconnect power to oven and discharge capacitors before following any disassembly procedure.

Fan Motor

1. Disconnect power to oven and remove outer case (see "Outer Case" section).
2. Discharge high voltage capacitor, (see "High Voltage Capacitor" section).
3. Remove rear air guide.
4. Remove screws securing diode to back panel.
5. Disconnect and label wires to high voltage capacitor.
6. Remove screws securing fan shroud to back panel and remove fan shroud from cavity.
7. Disconnect wires from fan motor terminals.
8. Carefully note fan blade direction and placement on motor shaft.
9. Pull fan blade from motor shaft.
10. Remove screws securing motor to shroud and remove motor.
11. Reassemble in reverse order.

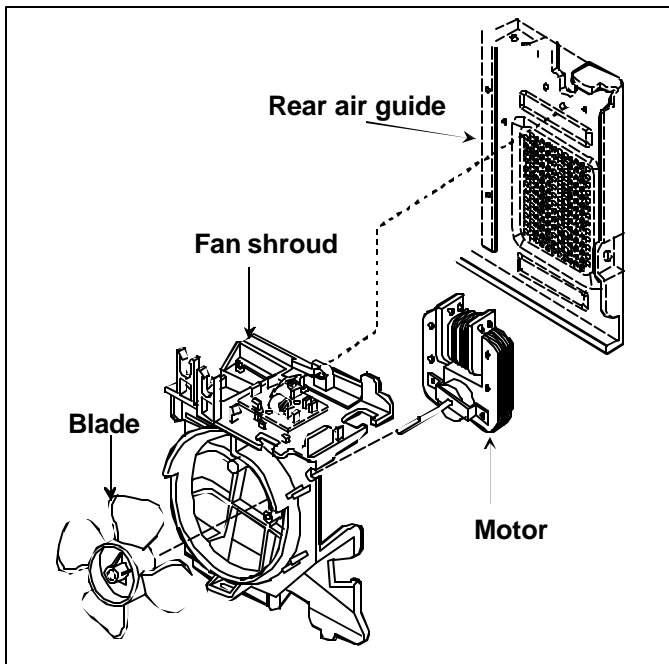

Cavity Thermostat

The cavity thermostat is located on top left side of cavity. Thermostat is a non–resettable thermostat.

1. Disconnect power to oven and remove outer case, (see "Outer Case" section).
2. Discharge high voltage capacitor, (see "High Voltage Capacitor" section).
3. Carefully bend one tab to release thermostat.
4. Disconnect wires from oven thermostat and replace thermostat.
5. Reassemble in reverse order.

Light Socket / Bulb Assembly

1. Disconnect power to oven and remove outer case, (see "Outer Case" section).
2. Disconnect wire terminal plug.
3. Carefully bend one tab to release socket.
4. Remove light socket / bulb assembly.
5. Replace and reassemble in reverse order.

Stirrer Motor

1. Disconnect power to oven.
2. Place oven on it's back.

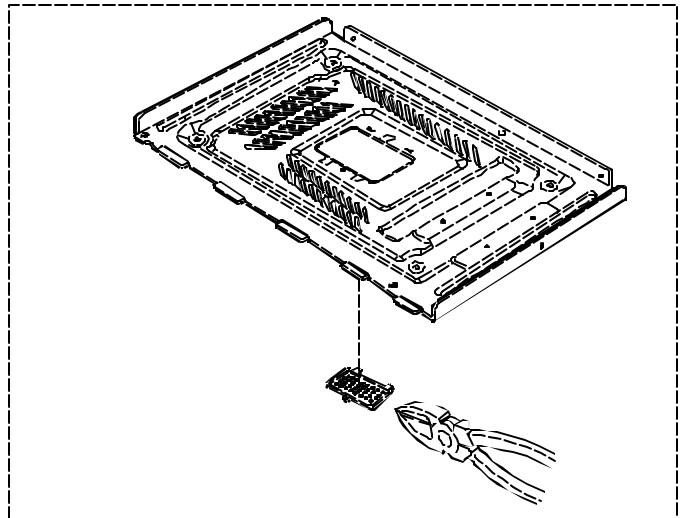

3. Remove bottom plate cover, by cutting metal tabs

NOTE: When reinstalling plate cover use screw provided.

4. Disconnect wires from motor terminals.
5. Remove screws securing motor to oven cavity.

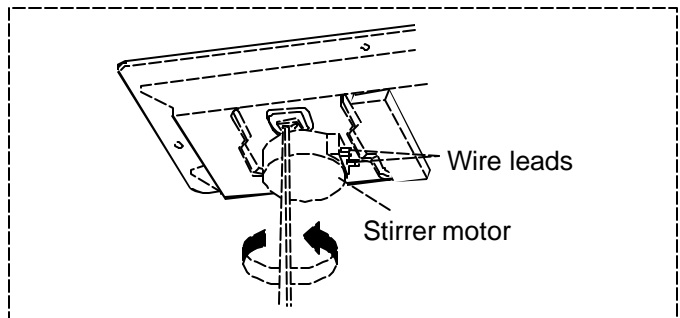

6. Replace and reassemble in reverse order.