

Technical Bulletin

Type	Policy Letter √Service Information	Date: October 2013
Attention	Service Managers √Service and Parts Managers	No: TCM-0083-B ITCM-0059-B
Product	Compact Models: HDC*, CRC*, DEC*, UHDC*	Page 1 of 3
Issue	Change in magnetron	
Warranty	Standard product warranty applies.	

Action Magnetron kits 59004013 and 59001997 may contain a magnetron larger than the original magnetron. When using the new magnetron remove 2 foam pads from front and 2 foam pads from rear duct for the magnetron you are replacing, upper or lower, as shown below. Adjust air duct fins to accommodate replacement magnetron.

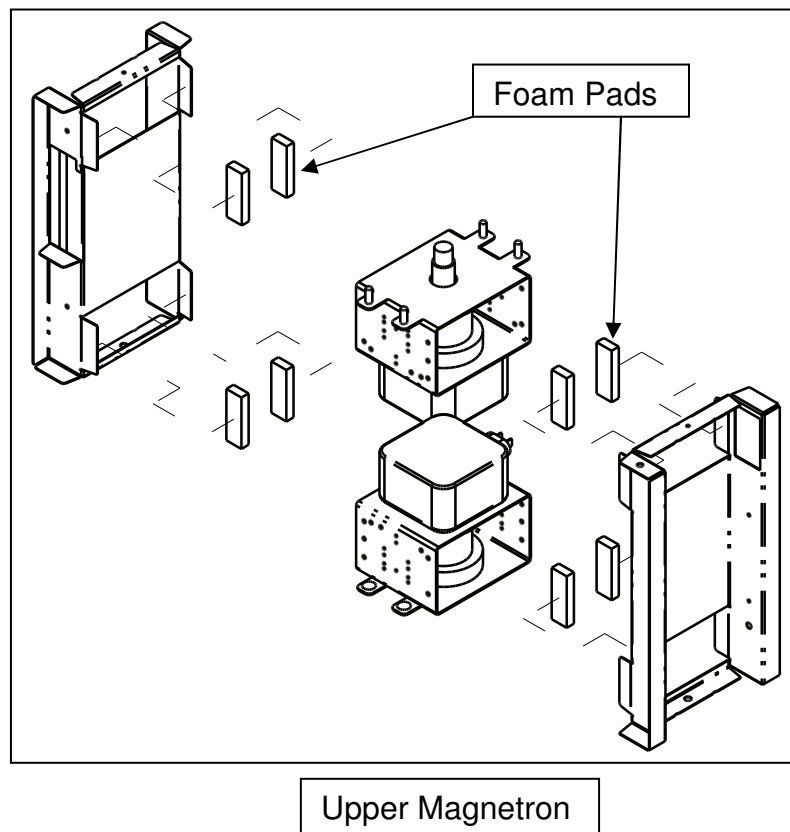

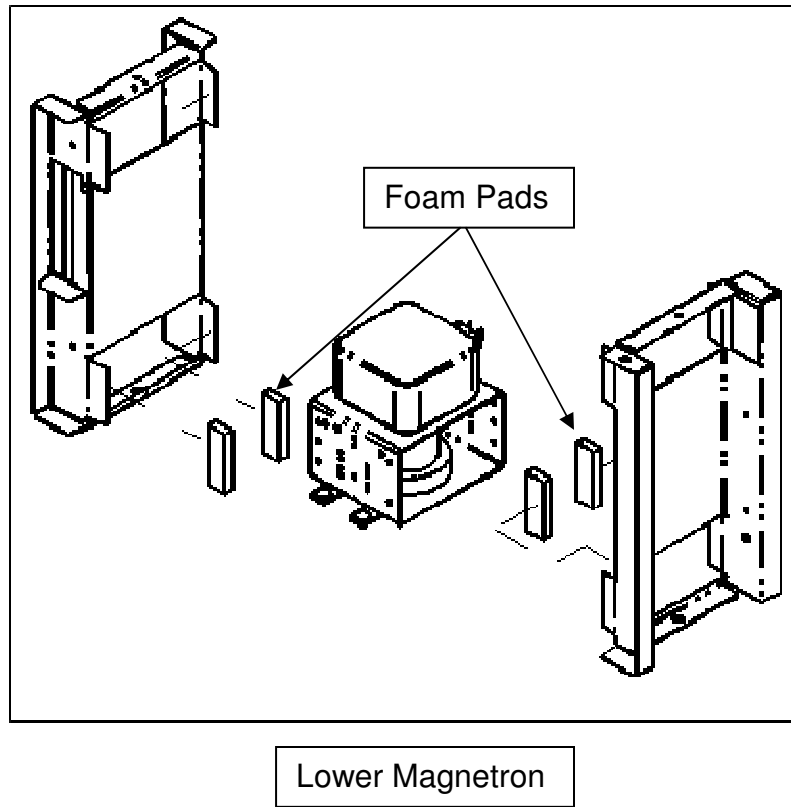

2. If application requires magnetron with no studs, use the following procedure to remove magnetron mounting studs.
 - a. Place magnetron mounting stud over a socket slightly larger than the size of the mounting stud on the edge of a sturdy work surface (Figure 1).
 - b. Use a hammer to knock the mounting stud into the socket taking care not to bend the magnetron mounting ears (Figure 2, Figure 3).
 - c. Repeat on all remaining magnetron mounting studs.

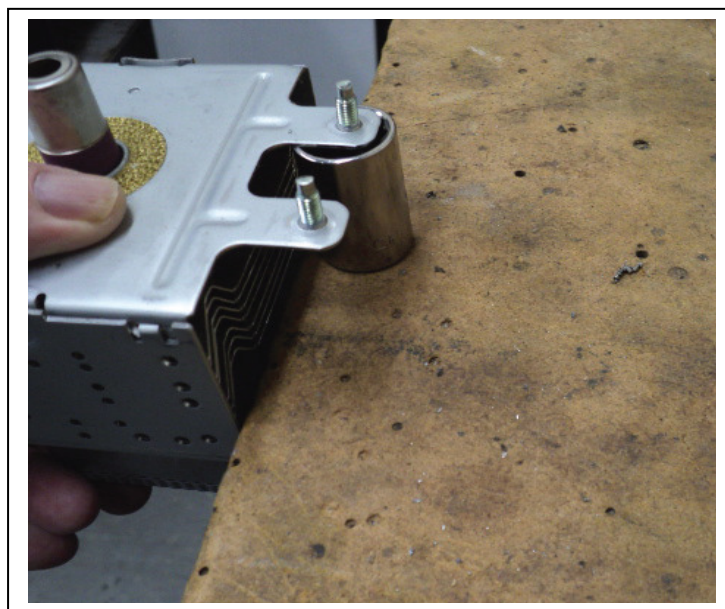

Figure 1

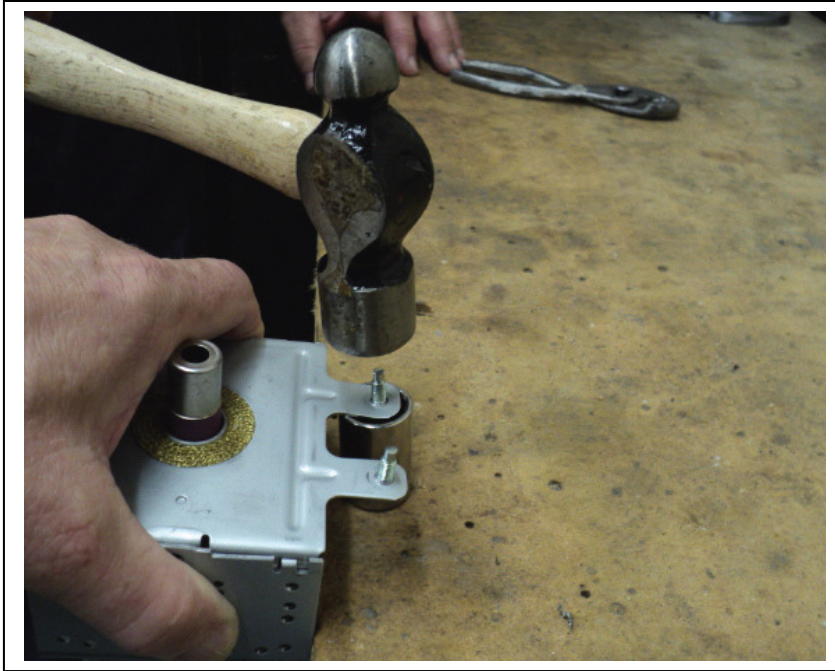

Figure 2

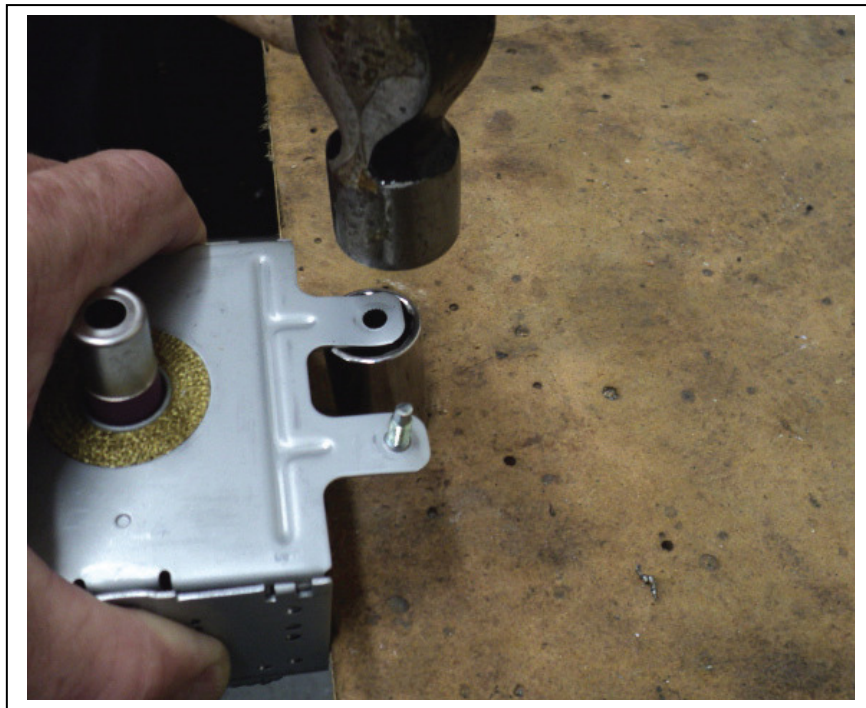

Figure 3