

This Manual covers the MRX2SW High Speed Combination Ovens equipped with Touch Screen Controls. Refer to individual Service Manuals or Technical Sheets for information on other specific models.

# Service

**MRX2SW**

## High Speed Combination Oven for Subway® Restaurants

Service Manual

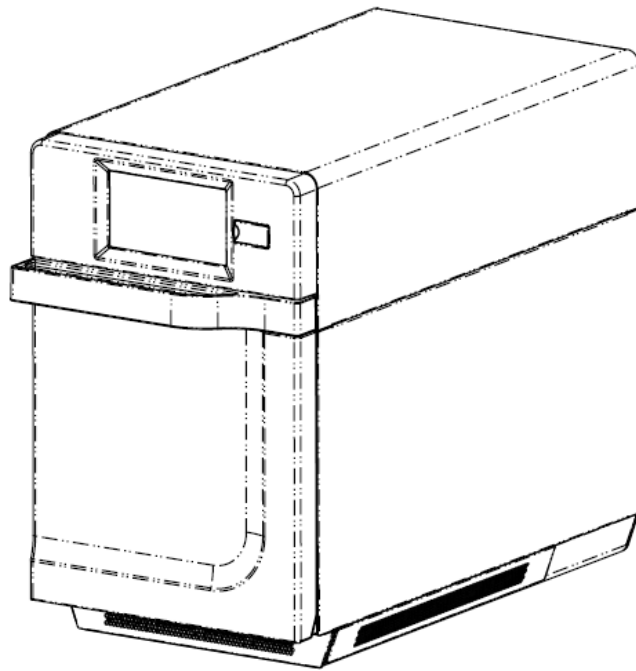

This manual is to be used by qualified service technicians only. ACP, Inc. does not assume any responsibility for property damage or personal injury for improper service procedures done by an unqualified person.

# TABLE OF CONTENTS

<b>IMPORTANT SAFETY INFORMATION</b> .....	1
Specifications.....	5
Installation.....	6
Quick Start Reference Guide.....	7
Firmware Update Procedure.....	9
Care and Cleaning.....	10
Oven Construction.....	11
Component Testing Procedures.....	17
Interlock Switch Service.....	19
Service Test Mode.....	20
Error Code List.....	23
Microwave Power Test.....	24
Control Board Wiring.....	25
Wiring Diagrams / Schematics .....	26



<http://services.acpsolutions.com>

**SERVICE & PARTS SUPPORT**

# IMPORTANT SAFETY INSTRUCTIONS

## Important Notices for Servicers and Consumers

ACP will not be responsible for personal injury or property damage from improper service procedures. Pride and workmanship go into every product to provide our customers with quality products. It is possible, however, that during its lifetime a product may require service. Products should be serviced only by a qualified service technician who is familiar with the safety procedures required in the repair and who is equipped with the proper tools, parts, testing instruments and the appropriate service information. **IT IS THE TECHNICIANS RESPONSIBILITY TO REVIEW ALL APPROPRIATE SERVICE INFORMATION BEFORE BEGINNING REPAIRS.**



### WARNING

To avoid risk of severe personal injury or death, disconnect power before working/servicing on appliance to avoid electrical shock.

ComServ Support Center

Web Site

WWW.ACPSOLUTIONS.COM

E-Mail: [commercialservice@acpsolutions.com](mailto:commercialservice@acpsolutions.com)



**866-811-8559**

Telephone Number

1-866-811-8559 or 319-368-8195

### Recognize Safety Symbols, Words, and Labels



### DANGER

**DANGER**— Immediate hazards which **WILL** result in severe personal injury or death.



### WARNING

**WARNING**— Hazards or unsafe practices which **COULD** result in severe personal injury or death.



### CAUTION

**CAUTION**— Hazards or unsafe practices which **COULD** result in minor personal injury, product or property damage.

## WARNING

Read the following information to avoid possible exposure to microwave radiation:

The basic design of the Microwave Oven makes it an inherently safe device to both use and service. However, there are some precautions which should be followed when servicing the microwave to maintain this safety. These are as follows:

1. Always operate the unit from an adequately grounded outlet. Do not operate on a two-wire extension cord.
2. Before servicing the unit (if unit is operable) perform the microwave leakage test.
3. The oven should never be operated if the door does not fit properly against the seal, the hinges or hinge bearings are damaged or broken; the choke is damaged, (pieces missing, etc.); or any other visible damage can be noted. Check the choke area to ensure that this area is clean and free of all foreign matter.
4. If the oven operates with the door open and produces microwave energy, take the following steps:
  - A. Tell the user not to operate the oven.
  - B. Contact ACP ComServ immediately.
5. Always have the oven disconnected when the outer case is removed except when making the "live" tests called for in the Service Manual. Do not reach into the equipment area while the unit is energized. Make all connections for the test and check them for tightness before plugging the cord into the outlet.
6. Always ground the capacitors on the magnetron filter box with an insulated-handle screwdriver before working in the high voltage area of the equipment compartment. Some types of failures will leave a charge in these capacitors and the discharge could cause a reflex action which could make you injure yourself.
7. Always remember that in the area of the transformer there is HIGH VOLTAGE. When the unit is operating keep this area clear and free of anything which could possibly cause an arc or ground, etc.
8. Do not for any reason defeat the interlock switches there is not valid reason for this action at any time; nor will it be condoned by ACP.
9. **IMPORTANT:** Before returning a unit to a customer, be sure to check for proper switch interlock action.
10. The Microwave Oven should never be operated with any components removed and/or bypassed or when any of the safety interlocks are found to be defective, or when any of the seal surfaces are defective, missing, or damaged.
11. All microwave ovens meet all requirements of the radiation control for Health and Safety Act of 1968. Due to measurement uncertainties, the maximum leakage for the field will be  $4\text{mw}/\text{cm}^2$ .
12. To ensure that the unit does not emit excessive microwave leakage and to meet the Department of Health and Human Services guidelines, check the oven for microwave leakage using a microwave oven leakage meter that complies with US Government CDRH/FDA/DHHS requirements and or any other local government requirements. The maximum leakage level allowed by ACP is  $4\text{mw}/\text{cm}^2$ .
13. If servicer encounters an emission reading over  $4\text{mw}/\text{cm}^2$ , the servicer is to cease repair and contact the ACP ComServ Department immediately for further direction. ACP will contact the proper Government Agency upon verification of the test results.



## Recognize this symbol as a SAFETY message



### WARNING

When using electrical equipment, basic safety precautions should be followed to reduce the risk of burns, electrical shock, fire, or injury to persons including the following.

1. READ all instructions before using equipment.
2. READ AND FOLLOW the specific "PRECAUTIONS TO AVOID POSSIBLE EXPOSURE TO EXCESSIVE MICROWAVE ENERGY" on this page.
3. This equipment **MUST BE GROUNDED**. Connect only to properly GROUNDED outlet. See "GROUNDING / EARTHING INSTRUCTIONS" on page 5.
4. Install or locate this equipment **ONLY** in accordance with the installation instructions in this manual.
5. Some products such as whole eggs and sealed containers—for example, closed glass jars—are able to explode and **SHOULD NOT** be HEATED in this oven.
6. Use this equipment **ONLY** for its intended use as described in this manual. Do not use corrosive chemicals or vapors in this equipment. This type of oven is specifically designed to heat, cook, or dry food. It is not designed for industrial or laboratory use.
7. As with any equipment, **CLOSE SUPERVISION** is necessary when used by **CHILDREN**.
8. See door cleaning instructions.
9. **DO NOT** heat baby bottles in oven.
10. Baby food jars shall be open when heated and contents stirred or shaken before consumption, in order to avoid burns.
11. **DO NOT** operate this equipment if it has a damaged cord or plug, if it is not working properly, or if it has been damaged or dropped.
12. This equipment, including power cord, must be serviced **ONLY** by qualified service personnel. Special tools are required to service equipment. Contact nearest authorized service facility for examination, repair, or adjustment.
13. **DO NOT** cover or block louvers or other openings on equipment.
14. **DO NOT** store this equipment outdoors. **DO NOT** use this product near water – for example, near a kitchen sink, in a wet basement, a swimming pool, or a similar location.
15. **DO NOT** immerse cord or plug in water.
16. Keep cord **AWAY** from HEATED surfaces.
17. **DO NOT** let cord hang over edge of table or counter.
18. For commercial use only.

## SAVE THESE INSTRUCTIONS



## WARNING

To avoid risk of fire in the oven cavity:

- a. DO NOT overcook food. Carefully attend oven when paper, plastic, or other combustible materials are placed inside the oven to facilitate cooking.
- b. Remove wire twist-ties from paper or plastic bags before placing bag in oven.
- c. If materials inside the oven ignite, keep oven door CLOSED, turn oven off and disconnect the power cord, or shut off power at the fuse or circuit breaker panel.
- d. DO NOT use the cavity for storage. DO NOT leave paper products, cooking utensils, or food in the cavity when not in use.



## WARNING

Liquids such as water, coffee, or tea are able to be overheated beyond the boiling point without appearing to be boiling due to surface tension of the liquid. Visible bubbling or boiling when the container is removed from the microwave oven is not always present. THIS COULD RESULT IN VERY HOT LIQUIDS SUDDENLY BOILING OVER WHEN A SPOON OR OTHER UTENSIL IS INSERTED INTO THE LIQUID. To reduce the risk of injury to persons:

- i) Do not overheat the liquid.
- ii) Stir the liquid both before and halfway through heating it.
- iii) Do not use straight-sided containers with narrow necks.
- iv) After heating, allow the container to stand in the microwave oven for a short time before removing the container.
- v) Use extreme care when inserting a spoon or other utensil into the container.



## CAUTION

To avoid personal injury or property damage, observe the following:

1. Do not deep fat fry in oven. Fat could overheat and be hazardous to handle.
2. Do not cook or reheat eggs in shell or with an unbroken yolk using microwave energy. Pressure may build up and erupt. Pierce yolk with fork or knife before cooking.
3. Pierce skin of potatoes, tomatoes, and similar foods before cooking with microwave energy. When skin is pierced, steam escapes evenly.
4. Do not operate equipment without load or food in oven cavity.
5. Microwave popcorn should not be popped in oven.
6. Do not use regular cooking thermometers in oven. Most cooking thermometers contain mercury and may cause an electrical arc, malfunction, or damage to oven.
7. Do not use metal utensils in oven.
8. Do not use aluminum foil in oven.
9. Never use paper, plastic, or other combustible materials that are not intended for cooking.
10. When cooking with paper, plastic, or other combustible materials, follow manufacturer's recommendations on product use.
11. Do not use paper towels which contain nylon or other synthetic fibers. Heated synthetics could melt and cause paper to ignite.
12. Do not heat sealed containers or plastic bags in oven. Food or liquid could expand quickly and cause container or bag to break. Pierce or open container or bag before heating.
13. To avoid pacemaker malfunction, consult physician or pacemaker manufacturer about effects of microwave energy on pacemaker.
14. An authorized servicer MUST inspect equipment annually. Record all inspections and repairs for future use.

# SAVE THESE INSTRUCTIONS

# SPECIFICATIONS

<b>Power Source Voltage</b>	208/240 VAC 30A, Single Phase, 3 Wire Grounded
<b>Automatic Voltage Sensing</b>	Yes
<b>Plug Configuration</b>	NEMA 6-30
<b>Power Consumption</b>	5650W, 28.4A
<b>Convection Heater Only</b>	3070W
<b>Power Output – Microwave (IEC705)</b>	2000W
<b>Minimum Temperature Rise (<math>\Delta T</math>)</b>	20°F (11°C)
<b>Microwave Operating Frequency</b>	2450mhz
<b>Temperature Range F/C</b>	200F-520F/95C-270C
<b>Connectivity</b>	USB, Wifi, & Ethernet
<b>Control Type</b>	7in/178mm Capacitance
<b>Dimensions Cabinet (in/cm)</b>	
<b>Width</b>	14in/356mm
<b>Height</b>	22.75in/577mm
<b>Depth (includes handle)</b>	29.125in/739mm
<b>Oven Interior (in/cm)</b>	
<b>Width</b>	12.25in/312mm
<b>Height</b>	7in/178mm
<b>Depth</b>	12.25in/312mm
<b>Weight (lbs/kg)</b>	
<b>Uncrated</b>	133lbs/60kg
<b>Crated</b>	158lbs/72kg
<b>Stackable</b>	Yes, with optional stacking cart

# INSTALLATION

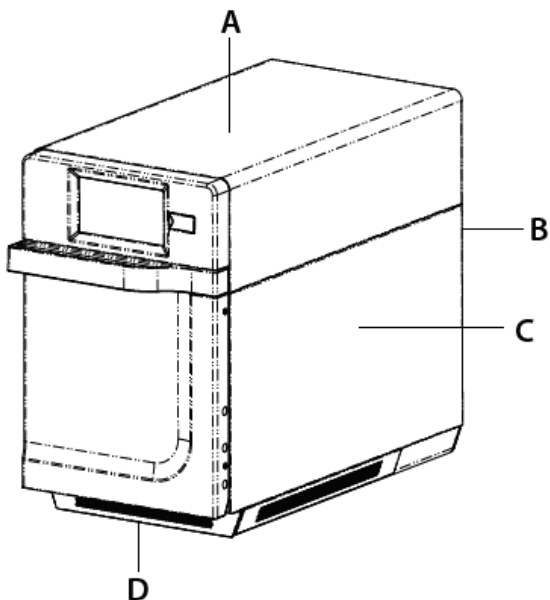

- A. Allow at least 2in (5.1cm) of clearance around top of oven. Proper air flow around oven cools electrical components. With restricted air flow, oven may not operate properly and life of electrical parts is reduced.
- B. Do not remove back panel bumpers. They ensure proper clearance.
- C. Allow at least 1in (2.54cm) of clearance around sides of oven.
- D. Install oven so oven bottom is at least 3 feet (91.5cm) above the floor.

## STEP 1 - Unpack Oven

- A. Inspect oven for damage such as dents in door or inside oven cavity.
- B. Report any dents or breakage to source of purchase immediately.  
**Do not attempt to use oven if damaged.**
- C. Remove all packing materials from oven interior.
- D. If oven has been stored in extremely cold area, wait a few hours before connecting power.

## STEP 2 - Place Oven on Counter

- E. Recommended countertop surface depth is 28in (72 cm).
- F. Do not install oven next to or above source of heat, such as a pizza oven, grill, or deep fat fryer. This could cause oven to operate improperly and could shorten the life of electrical parts due to excessive heat and/or grease.
- G. Do not block or obstruct oven filters. Allow access for filters to be cleaned.
- H. Install oven on level countertop surface.
- I. Outlet should be located so that plug is accessible when oven is in place. Oven cord length is 60in (152cm)

## STEP 3 – Test Oven Operation

- J. Ensure cooking plate is installed.
  - 1. Oven cavity must be cool to touch.
  - 2. Place shelf in oven with curve positioned toward the front of the oven. This ensures proper convection air flow.
- K. **DO NOT** cook food directly on floor of oven.

# Quick Start Guide | MRX High Speed Oven for Subway® Restaurants

**Caution:** Uploading a new file will overwrite existing items on *OVEN*. To ensure items are not lost, first backup files by exporting to USB drive.

## Export Menu via USB Flash Drive

1. Touch the blue menu icon at the bottom of the screen.
2. Scroll down and touch the "Load File" option
3. When prompted, insert the flash drive into the USB port
4. When prompted, select "Export Files".  
"Copying Files" screen will appear.  
Do not remove USB Flash Drive until "Success" screen appears.
5. Once the file have copied, touch the "Home" icon to return to the main screen. Remove USB Flash Drive. Settings and menu items will be loaded on USB Flash Drive and ready to share or open in ACP Programming Application .

## Open Menu in ACP Programming Application

*Note: For more comprehensive instructions, see ACP Programming Application User Guide online*

1. Insert flash drive into USB port on computer.
2. Open ACP Programming Application.
3. Select "File," then "Open." Navigate to flash drive. Select the menu file and open.

## Import Menu via USB Flash Drive

1. Touch the blue menu icon at the bottom of the screen.
2. Scroll down and touch the "Load File" option  
**Caution:** Uploading a new file will overwrite existing items on oven. To ensure items are not lost, first backup files by exporting to USB drive.
3. When prompted, insert the flash drive into the USB port
4. Touch the desired file to be uploaded.
5. Once file has uploaded, touch the "Home" icon to return to the main screen. Settings and menu items will now be loaded and ready to use.

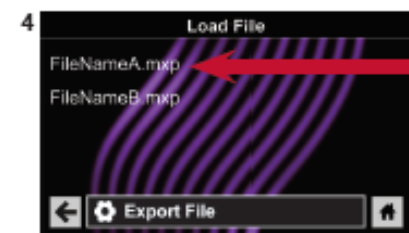
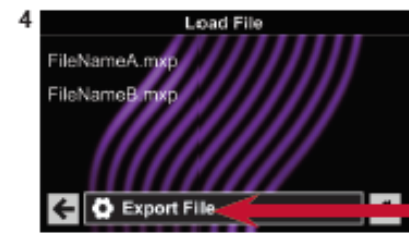
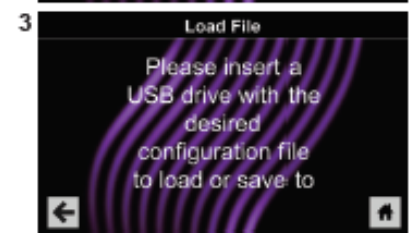
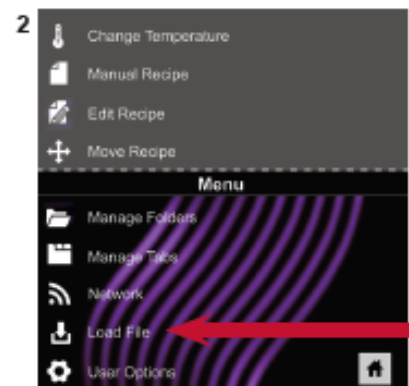

There are several options you can change to customize the operation of the oven for your business. The table below shows these options; the factory setting is shown in bold type.

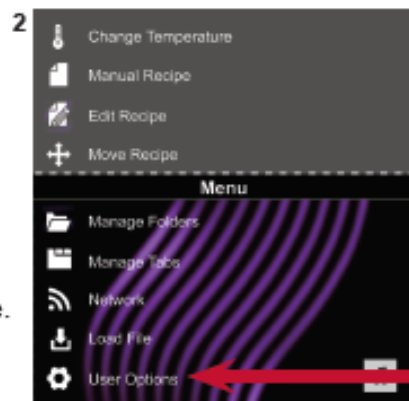

## Access and Modify User Options:



1. Touch the blue menu icon at the bottom of the screen.
2. Scroll down and touch to select "User Options."



3. Use this menu to modify oven settings.  
Touch the left arrow to return to the menu after making each change.

*Note: You may also make user options changes using the ACP Programming Application.*

User Option	STANDARD DEFAULT PER MODEL	
	MRX for Subway®, 60Hz	MRX for Subway, 50Hz
Language	<b>English</b> , Chinese (Mandarin), Japanese, Korean, Russian, German, French, Italian, Polish, Danish, Greek, Latin, Swedish, Portuguese, Spanish, Thai, Lao, Dutch, Vietnamese, Arabic, Ukrainian, Filipino, Norwegian, Hindi, Bengali	<b>English</b> , Chinese (Mandarin), Japanese, Korean, Russian, German, French, Italian, Polish, Danish, Greek, Latin, Swedish, Portuguese, Spanish, Thai, Lao, Dutch, Vietnamese, Arabic, Ukrainian, Filipino, Norwegian, Hindi, Bengali
Time	12 Hr 24 Hr	12 Hr 24 Hr
Date	MM / DD / YYYY DD / MM / YYYY	MM / DD / YYYY DD / MM / YYYY
Temperature Scale	Celsius <b>Fahrenheit</b>	<b>Celsius</b> Fahrenheit
Preheat Temperature 200°F - 520°F (93°C - 270°C)	<b>520°F ( 270°C )</b>	<b>270°C ( 520°F )</b>
Keypad Activation	30 seconds 60 seconds <b>2 minutes</b>	30 seconds 60 seconds <b>2 minutes</b>
Brightness	Low Med <b>High</b>	Low Med <b>High</b>
Key Beep	On <b>Off</b>	On <b>Off</b>
Volume	<b>Low</b> Medium High	<b>Low</b> Medium High
End of Cycle Beep	Three Beeps (Once) <b>Three Beeps (Repeating)</b> Continuous Until Door is Opened	Three Beeps (Once) <b>Three Beeps (Repeating)</b> Continuous Until Door is Opened
Allow Manual Cook	On <b>Off</b>	On <b>Off</b>
Allow Manual Save	On <b>Off</b>	On <b>Off</b>
PIN Code <i>*must be a 4-digit numeric PIN</i>	<b>On*</b> Off	<b>On*</b> Off
Opening Door Behavior	<b>Reset Timer</b> Pauses Cook Cycle	<b>Reset Timer</b> Pauses Cook Cycle
Clean Filter Reminder	Every 7 Days <b>Every 30 Days</b> Every 90 Days Off	Every 7 Days <b>Every 30 Days</b> Every 90 Days Off
Preheat Warning	On <b>Off</b>	On <b>Off</b>
Auto Shut Off	2 Hours <b>4 Hours</b> 8 Hours Off	2 Hours <b>4 Hours</b> 8 Hours Off

# FIRMWARE UPDATE PROCEDURE

The Touch Control is designed to be updated as future technology and programming requirements change. Should new firmware be required follow the steps below. Firmware updates are made available at:

**<http://acpsolutions.com/oven-programming/>**

1. Ensure the oven is powered on.
2. If the standby (off) screen is showing, press the green power button.
3. Press the blue menu button.
4. If the PIN is enabled, enter 1-3-5-7-9 to access service mode.
  - If the PIN is not enabled the menu will appear.
  - Touch and drag up to scroll to the bottom of the menu and select "User Options".
  - Touch and drag up to scroll down through the user options and select "PIN Code".
  - Select On, enter and remember a 4 digit Pin Code and then select the home button.
  - Now press the blue menu button and enter 1-3-5-7-9 to access service mode.
5. Ensure the software version displayed is less than the version being installed, then press the home button and proceed to program loading.
6. Select "Software Version".
7. Insert the USB/flash drive with the new firmware into the USB port.
8. A box will appear in the lower portion of the screen "Rev "xxx" Available Begin Update".
9. Press this box to begin firmware update. The screen will now display "Entering Standby Mode" for a few seconds and then the screen will go blank. Continue to wait.
10. The screen will blink, then a few seconds later the Startup logo will appear. Underneath will appear the word "Updating" along with a progress bar. Continue to wait. Note: Do not remove the USB/flash drive until AFTER the reboot is completed.
11. After about two minutes the words "Update Complete" will appear and a green "Reboot" button will appear. Do not remove the USB/flash drive. Press the green button.
12. Once the ACP logo and green power button appear, remove the flash drive and press the green power button.
13. Press the blue menu button and enter 1-3-5-7-9 to access service mode.
14. Verify the software version displayed is new version.
15. Press the home button.
16. The firmware update is complete.

# CARE AND CLEANING

Follow the recommendations below and on the following page for proper maintenance of Raptor ovens.

 The use of caustic cleaning products or those containing ammonia, phosphates, chlorine, sodium or potassium hydroxide (lye) can damage critical oven parts. Do not use water pressure type cleaning systems. Use of unapproved cleaning agents will void the terms of the warranty.

## Recommended Cleaning Supplies:

Damp towel, plastic scouring pad, ACP Oven Cleaner (Item CL10), ACP Oven Shield Oven Protectant (Item SH10), mild liquid dishwashing detergent, rubber gloves, safety glasses, microfiber cloth

## For a new oven, before using it for the first time:

When oven is clean, spray damp towel with ACP Oven Shield (SH10) and wipe all interior surfaces. Do not remove Oven Shield. Turn oven on and pre-heat to start cooking.

 **WARNING**

Wear protective gloves and protective glasses when cleaning the oven.

To prevent burns, handle utensils, accessories, and door with care. Allow oven, utensils, and accessories to cool before cleaning. Oven, utensils, and accessories become hot during operation.

Failure to maintain the oven in a clean condition could lead to deterioration of the surface that could adversely affect the life of the appliance and possibly result in a hazardous situation.

---

## Best Practices

- DO** clean oven daily.
- DO** use non-caustic cleaner.
- DO** wear protective gloves and glasses while cleaning.
- DO** always use recommended cleaning supplies: Damp towel, plastic scouring pad, ACP Oven Cleaner (CL10) and ACP Oven Shield Protectant (SH10).
- DO** allow oven and tools to cool before cleaning
- DO** remove food from oven at end of cycle.
- DO** use only accessories that are both high temperature oven-safe and microwave-safe.
- DO** wash cook plate with warm, soapy water and air dry
- DO** place cookware in center of oven rack, not touching oven sides.
- DO NOT** use caustic cleaning products or those containing ammonia, phosphates, chlorine, sodium or potassium hydroxide (lye).
- DO NOT** use water pressure style cleaning systems
- DO NOT** spray cleaning solution into perforations.
- DO NOT** cook foods with plastic wrap on them.
- DO NOT** use abrasive scouring pads to clean ceramic side covers or the red sealant surrounding each cover.
- DO NOT** operate oven without a load (empty) in microwave mode.
- DO NOT** use metal cookware with sides greater than 1 1/2" (3.8 cm) tall.

# OVEN CONSTRUCTION – CAVITY

TOP FORCED-AIR PLATE  
4 SCREWS TO REMOVE

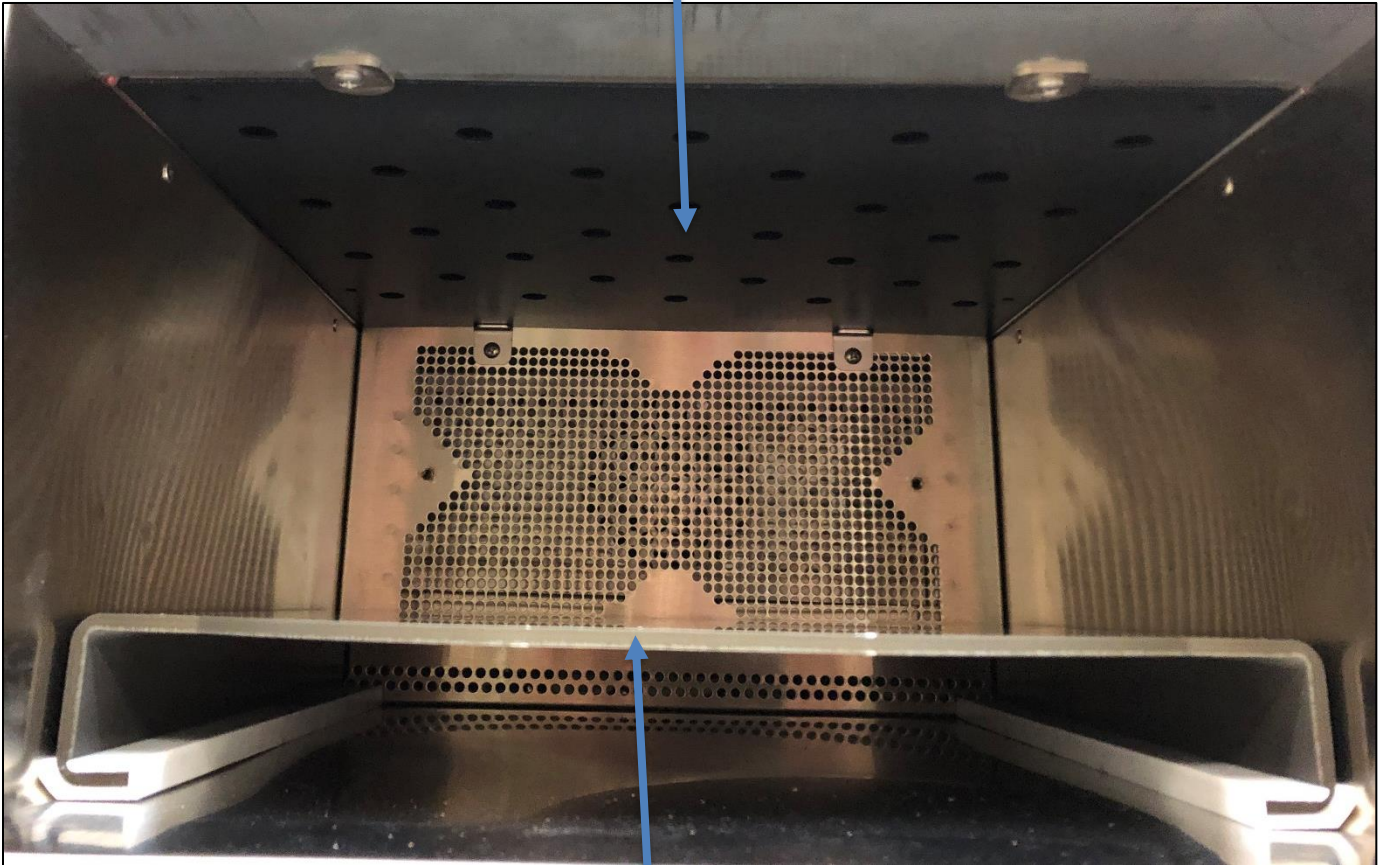

COOKING PLATE  
(MUST BE IN PLACE. ALLOWS  
AIR FLOW UNDER FOOD)

# OVEN CONSTRUCTION – ANTENNA BOX

## MICA COVER REMOVAL, AFTER FORCED AIR PLATE REMOVED

LOOSEN 2 FRONT SCREWS  
AND REMOVE 2 BACK SECURING  
TABS

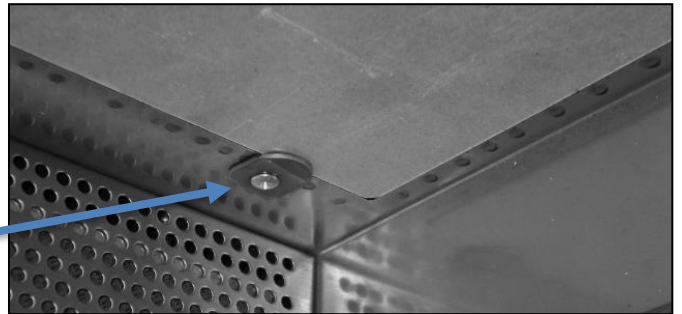

CAREFULLY PRY MICA COVER OUT OF  
POSITION USING SECURING TAB. HELD IN  
WITH HIGH TEMP GASKETS

ANTENNAS  
(From Inside Cavity)

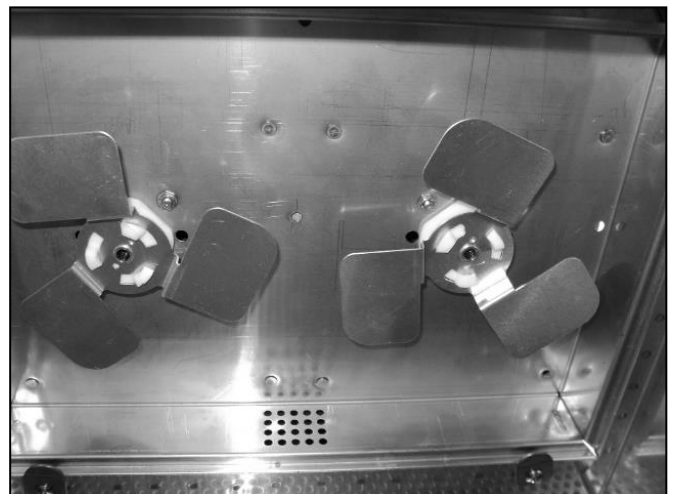

# OVEN CONSTRUCTION – RIGHT SIDE

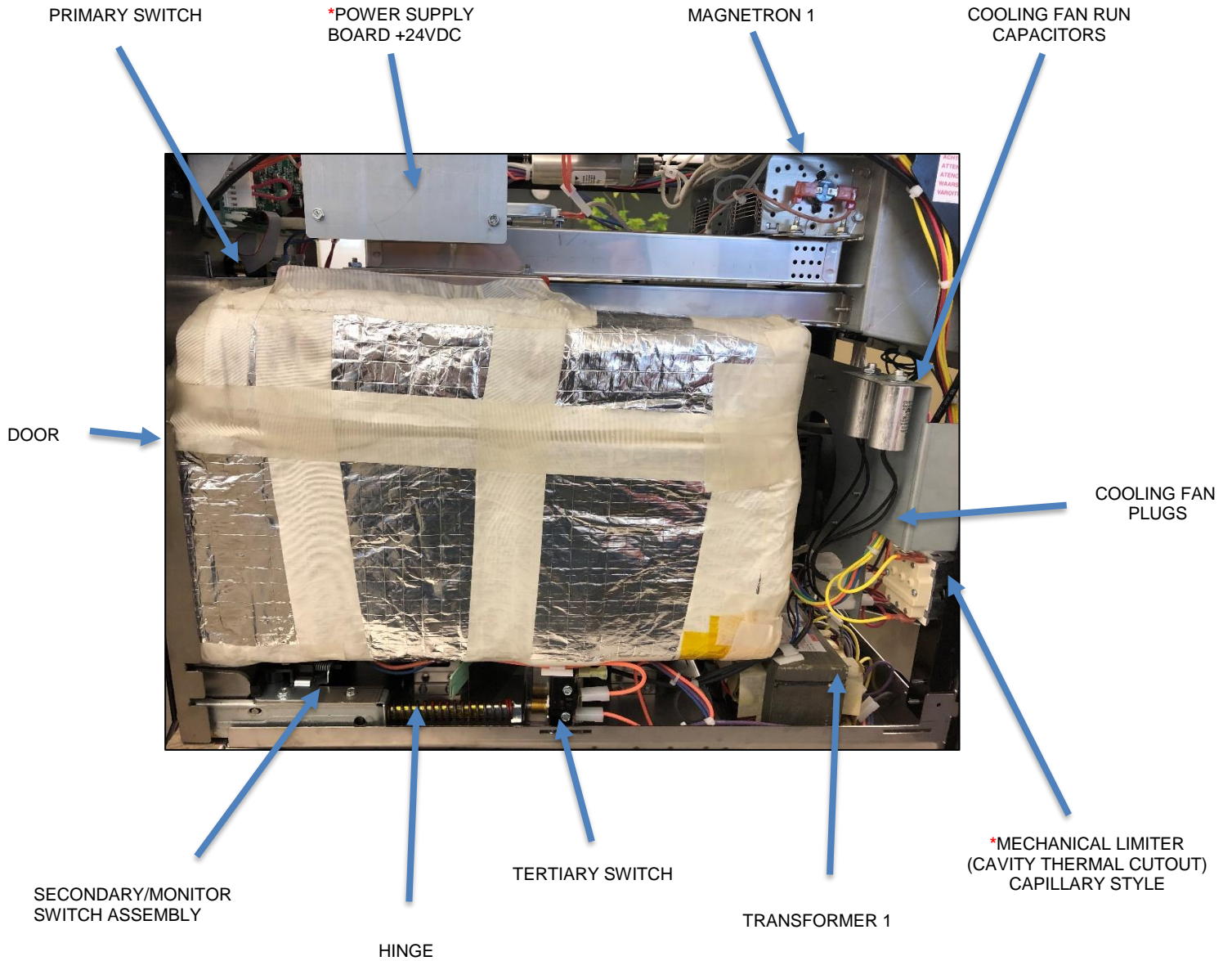

# OVEN CONSTRUCTION – LEFT SIDE

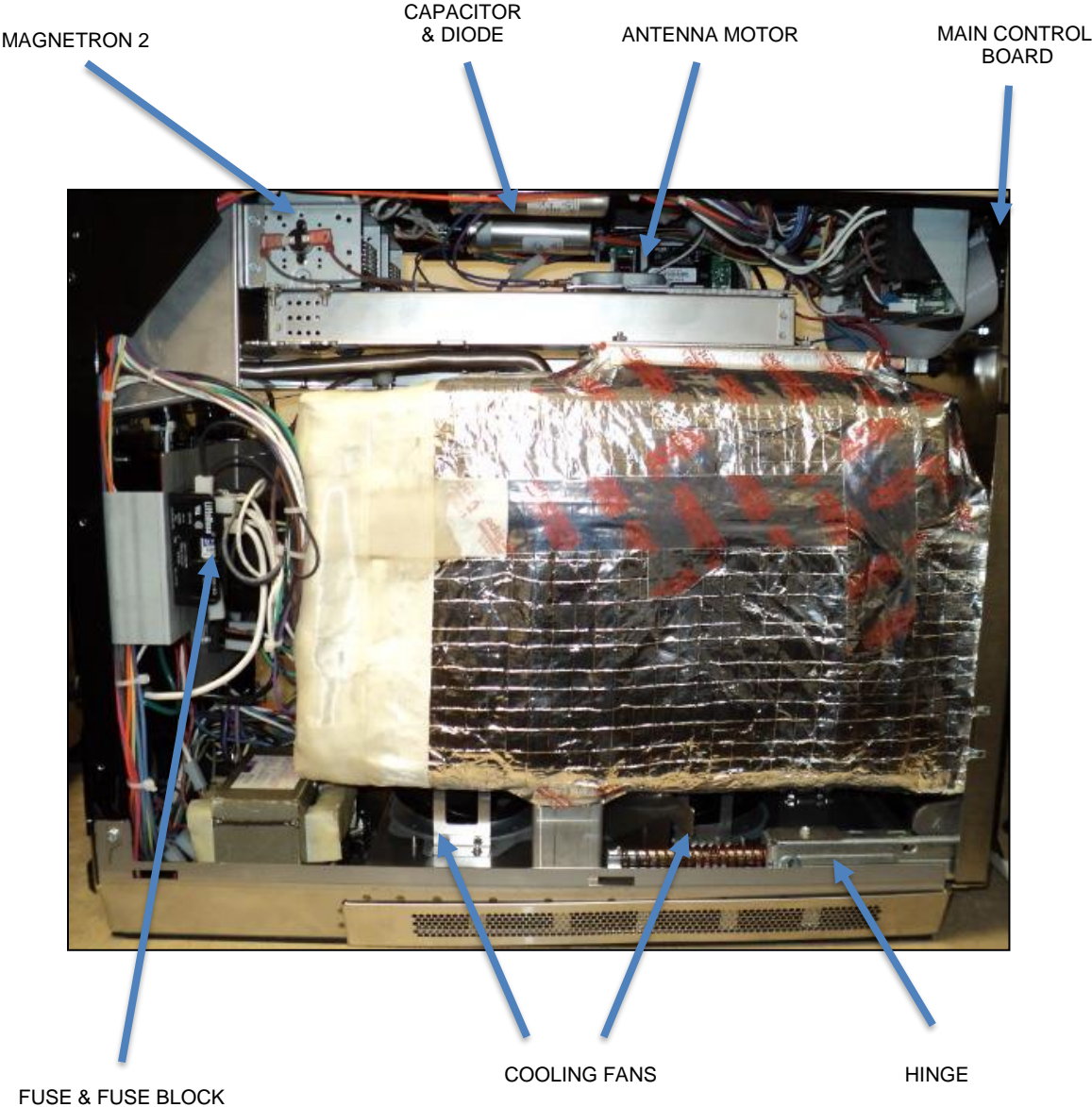

# OVEN CONSTRUCTION – BACK

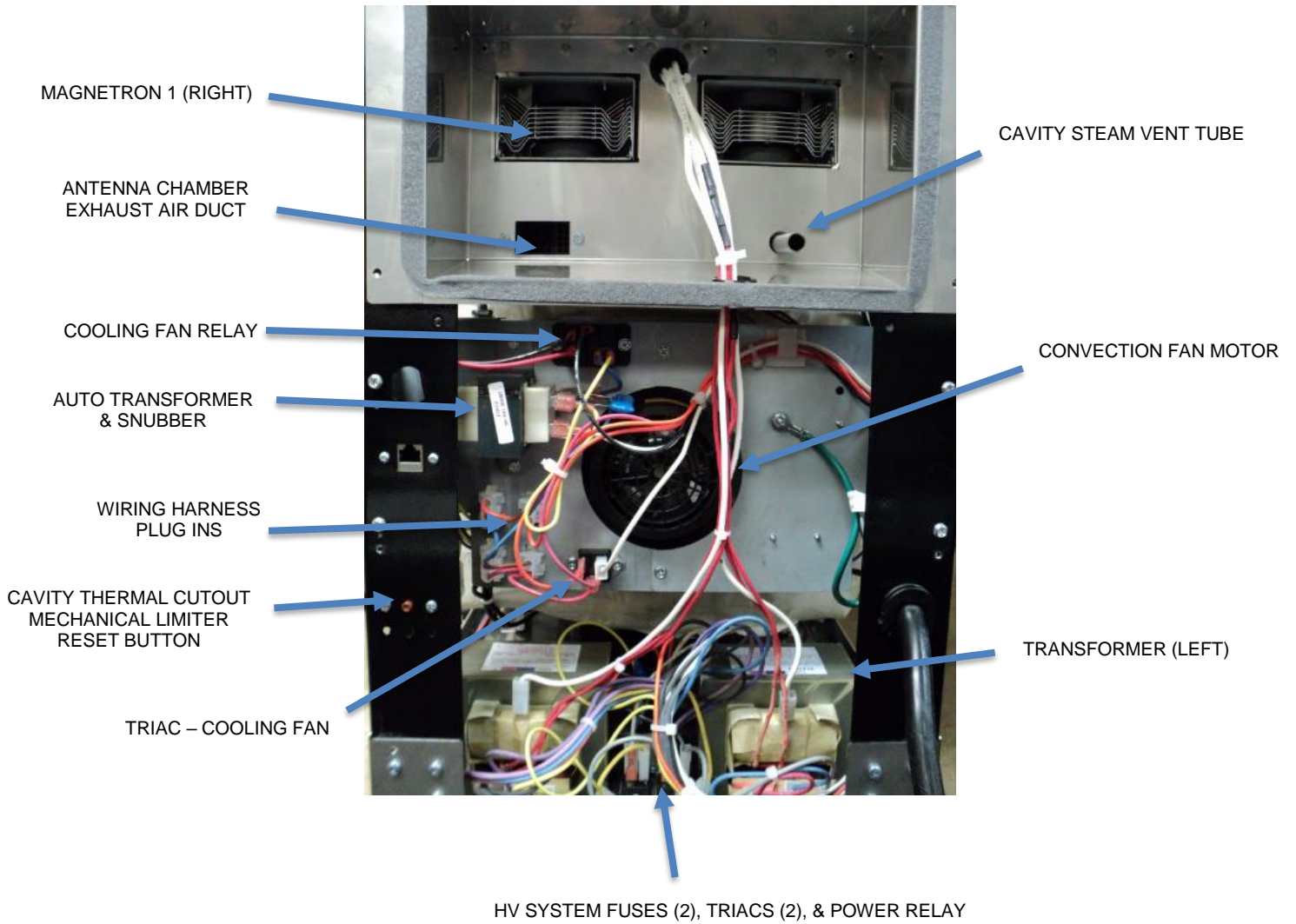





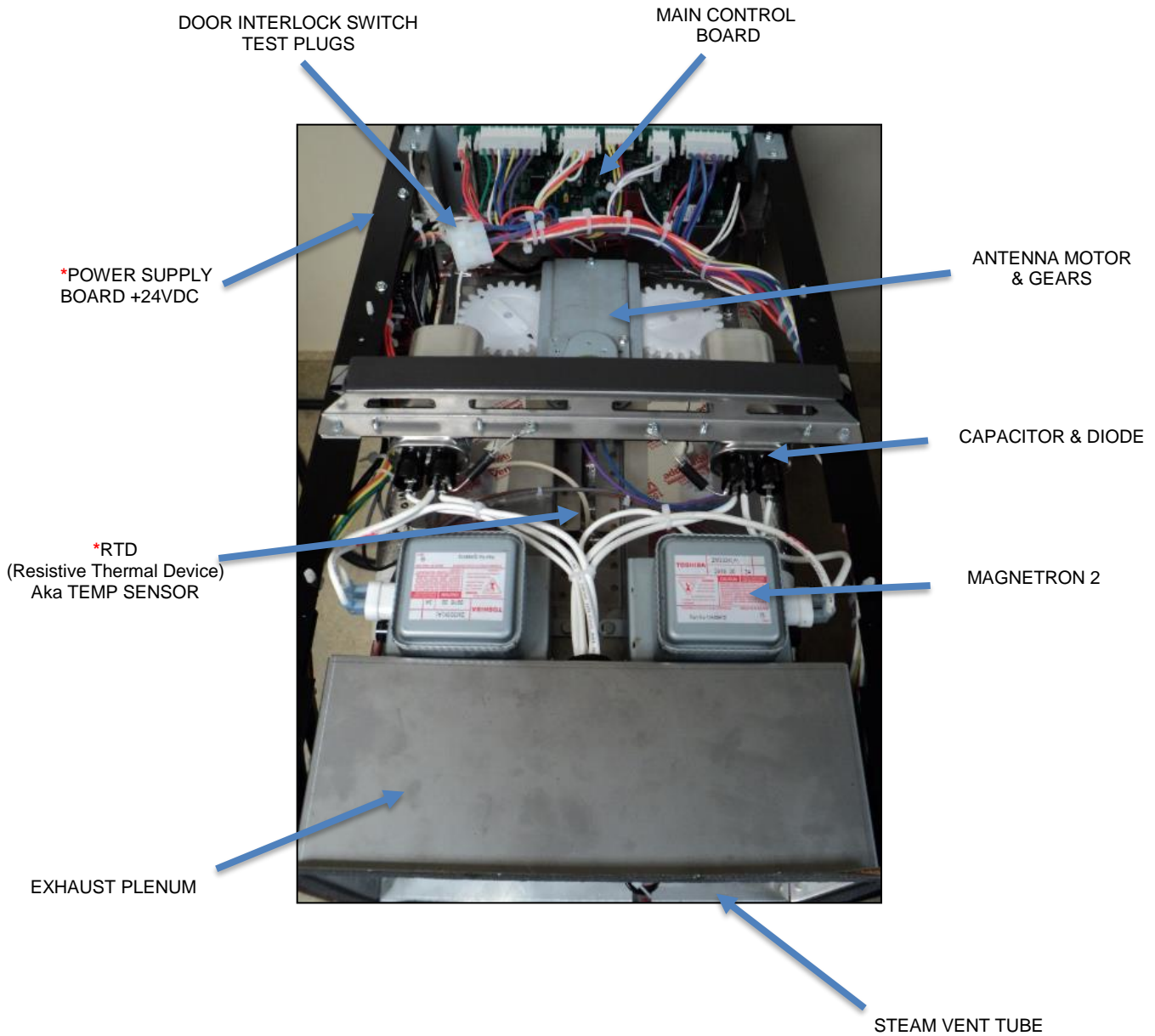

# OVEN CONSTRUCTION – TOP



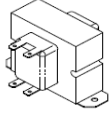
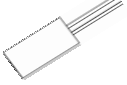
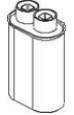
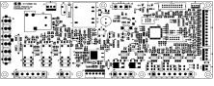
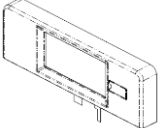

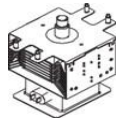

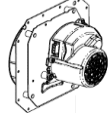



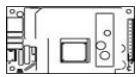
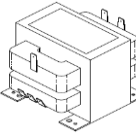

FRONT OF OVEN

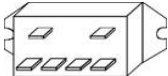

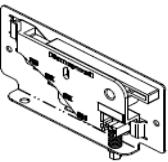
# COMPONENT TESTING PROCEDURES

Illustration	Component	Test	Results
	Auto Transformer	230 to 0 (Com)..... 208 to 0 ..... 120 to 0 (not used).....	Approximately: 38 Ω 35 Ω 25 Ω
	Capacitor, Cooling Fan Motor	Wire to Wire	1.5μf ± 5% 400V 50/60hz
	Capacitor, High Voltage	Terminal to Terminal	.88μf ± 3% 2100V 50/60hz
	Control Board, Main	See Service Test Mode Section	
	Control Board, Touch Screen Display	See Service Test Mode Section	
	Convection RTD (Resistive Thermal Device) aka Temp Sensor	Temperature: 70°F (23.9C)..... 350°F (176.7).....	Approximately: 1100Ω 1650Ω
	Fuses	F1 - BLN 250V 30A..... F3 & F4 250V 12A.....	CLOSED/Continuity
	Magnetron	<b>DISCHARGE CAPACITORS!</b> Wires Removed: Terminal to Terminal..... Both Terminals to Chassis.....	<1Ω OPEN (∞)
	Motor, Antenna	Wires Removed: Terminal to Terminal.....	Approximately: 12,000Ω (12KΩ)
	Motor, Convection Blower	With Line Voltage Applied & ST2 Connector Unplugged: ST1-1 to ST1-2.....	Motor not running with line voltage present indicates a failed motor assembly.
	Motor, Cooling Fan	Wires Removed: BU to BRN..... BU to BK..... BK to BRN.....	Approximately: 200Ω 685Ω 900Ω

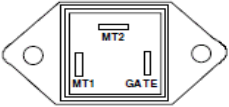
# COMPONENT TESTING PROCEDURES

Illustration	Component	Test	Results
	Power Supply Board	With Line Voltage Applied: J1-1 (WH) to J1-3 (BK) ..... J2-1 (RD) to J2-5,6,&7.....	Line Voltage AC Approximately 24VDC
	Power Transformer	<b>DISCHARGE CAPACITORS!</b> Wires Removed: COM to 208 or 230..... 5 to 6..... 4 to Chassis Ground.....	Resistance: <2Ω (Open to Ground) <1Ω (Open to Ground) Approximately 62.5Ω ± 5%
	Rectifier (Diode)	<b>DISCHARGE CAPACITORS!</b> Diode Removed from Capacitor	OPEN (∞) when measured in one direction, 50KΩ or more in the other direction. NOTE: Meter must have >6VDC Battery to effectively measure
	Relay, Fan (24VDC)	Wires Removed: BK to RD 3/16" Terminals..... BK (1/4") to YL Terminal..... BK to BU Terminals.....	Resistance: Approximately 550Ω (Solenoid) Normally Closed - Continuity Normally Open - OPEN (∞)
	Relay, Power (208/230VAC)	Wires Removed: 0 to 1..... 2 to 4 ..... 6 to 8 .....	Resistance: Approximately 550Ω (Solenoid) Normally OPEN (∞) Normally OPEN (∞)
	Snubber (Transformer & Relay)	Wires Removed: Terminal to Terminal .....	Normally OPEN (∞) .09μf
	Switch, Primary	Use Test Plug By Main Board: BU to RD Door Open ..... BU to RD Door Closed .....	Resistance: Continuity OPEN (∞) NOTE: When opening door, the Primary Switch should ALWAYS activate first.
	Switches, Monitor & Secondary	Use Test Plug with Door Closed: VT to BU (Monitor Switch) ..... VT to OR (Secondary Switch) .....	Resistance with Door Closed: OPEN (∞) Continuity NOTE: When opening door, the Primary Switch should ALWAYS activate first.
	Thermal Cutout (TCO), Cavity	Wires Removed (one set is used): 11 to 12..... 21 to 22 ..... 31 to 32.....	With Mechanical Reset Button "in": Continuity at Temperatures Between 608°F (320C) and 32°F (0C)
	Thermal Cutout (TCO), Magnetron	Wires Removed: Terminal to Terminal.....	Opens at 300°F (320C). Resets at 257°F (125C)
	Triac (Fan, Heater, & Transformer)		Wires Removed: MT1 to Gate Approximately 50Ω MT1 to MT2 - OPEN (∞) MT2 to Gate - OPEN All Terminals OPEN (∞) to Ground
	Convection Heater	Wires Removed: Terminal to Terminal.....	Resistance: Approximately 15Ω

# INTERLOCK SWITCH SERVICE

*NOTE: THE PRIMARY AND TERTIARY (FOUND AT THE BACK OF THE LEFT HINGE SPRING) SWITCHES ARE NOT ADJUSTABLE.*

## TO REMOVE THE SECONDARY/MONITOR SWITCH ASSEMBLY:

- 1) OPEN THE DOOR
- 2) REMOVE THE 5/16in (10mm) SECURING NUT and SLIDE SWITCH ASSEMBLY OUT

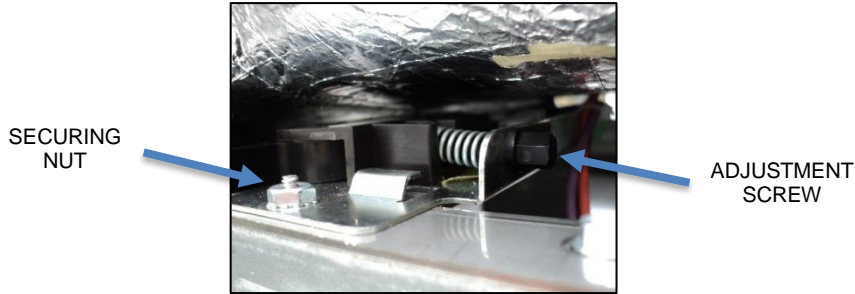

## TO REINSTALL AND PROPERLY REPLACE THE DOOR SWITCH ASSEMBLY:

- 1) WITH THE DOOR OPEN, SLIDE SWITCH BACK INTO SWITCH BRACKET AND TIGHTEN THE 5/16in (10mm) NUT.
- 2) USING AN OHMMETER WITH PROBES INSERTED INTO THE VT AND BU WIRES ON THE SECONDARY/MONITOR SWITCH TEST PLUG, ADJUST MONITOR SWITCH TO OPERATE WHEN DOOR IS OPEN TO ONE (1) INCH AT THE TOP OF THE DOOR.

*NOTE: TIGHTENING ¼" ADJUSTMENT SCREW MAKES INTERLOCK ACTIVATE SOONER WHEN THE DOOR IS BEING CLOSED. OVERTIGHTENING WILL CAUSE DAMAGE TO INTERLOCK ASSEMBLY*

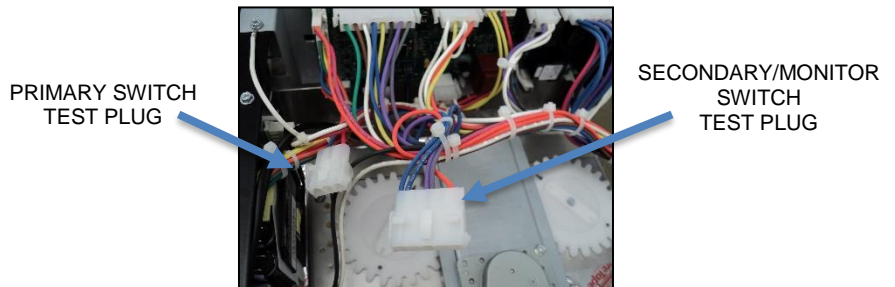

SWITCH	DOOR CLOSED	CHANGES	TEST PLUG
PRIMARY	OPEN	At ¼ in	BU TO RD
SECONDARY	CLOSED	At ½ in	VT to OR
MONITOR	OPEN	At 1 in	VT to BU
TERTIARY SWITCH	CLOSED	At approx 6 inches	NO TEST PLUG

# SERVICE TEST MODE

The Service Mode is a useful tool to aid in diagnosing any service issue. To access the oven's service test mode, **the PIN Code must be enabled**. If the PIN Code is not enabled, enable it (See Below). To determine if the PIN CODE is enabled, press the blue menu icon. If the PIN Code prompt appears it is enabled. The touch control system installed in this model is used in other ovens so some components tests will not work properly.

With the PIN Code enabled;

1. Press green start pad
2. Press the blue menu icon and the PIN Code prompt will display
3. Enter, in order, 1, 3, 5, 7, 9 and the Service Mode is initiated



If the PIN Code is not enabled, it must be enabled in the User's Options. With oven on, press the blue menu icon at the bottom of the screen;

1. Press the blue menu icon and the PIN Code prompt will display
2. Scroll screen to "User Options" and press it.
3. Scroll screen to PIN Code (it will say "DISABLED" underneath) and press it.
4. Press the radial pad "On" and ensure it is lit.
5. Enter 1,2,3,4 as PIN Code and memorize, take a picture, or write it down.
6. Press the "Home" icon to return to Main Screen
7. Press the blue menu icon and the PIN Code prompt will display
8. Enter, in order, 1, 3, 5, 7, 9 and the Service Mode is initiated

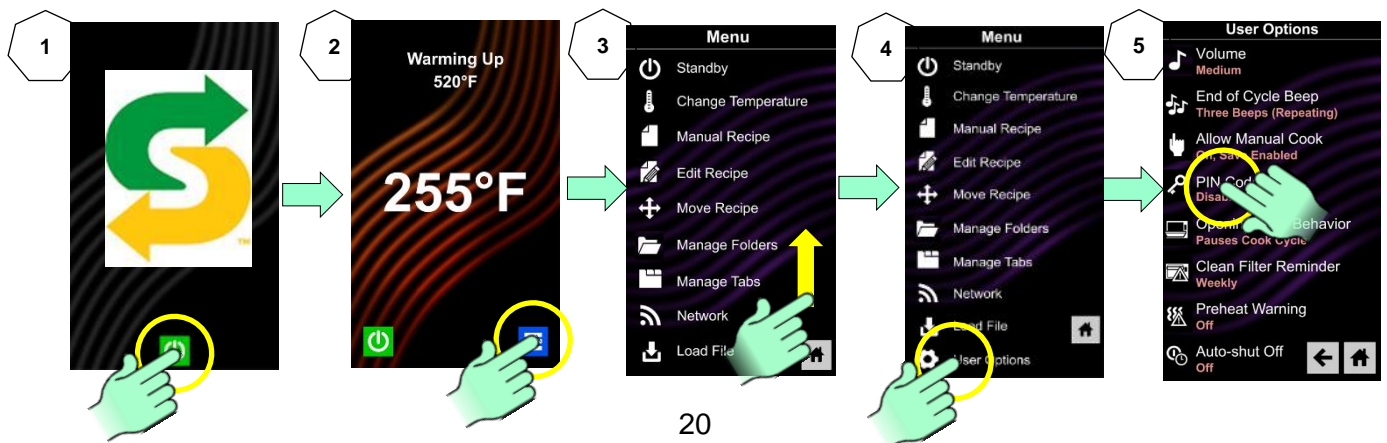

Once the Service Mode is initiated a menu of options and information is displayed. The menu screen can be navigated by swiping up or down if needed. Some components can be activated from this menu – See example of Magnetron 1 (Right Side) below, by touching start to start or stop to stop. Pressing the “back arrow” will return back on screen. Pressing the “home” icon returns to opening screen.

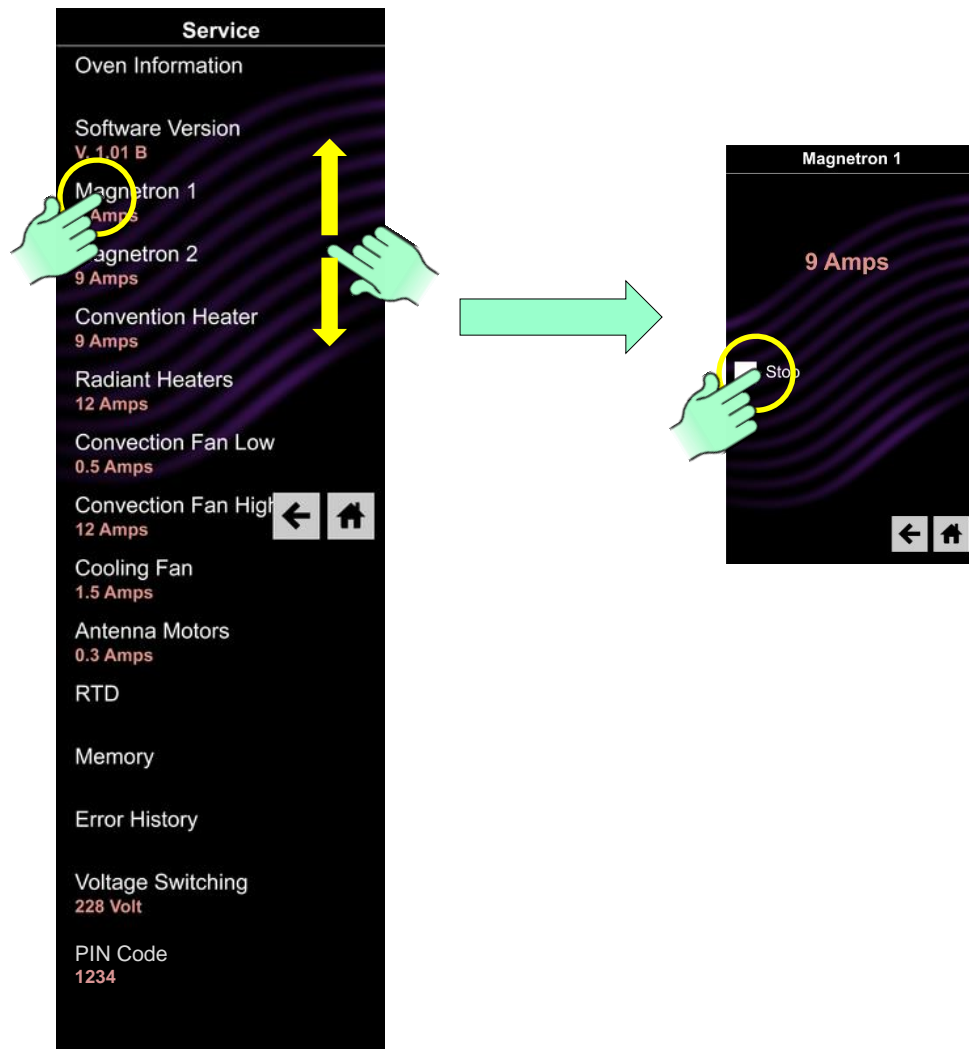

Service Mode	Purpose	Comments
<b>Oven Information</b>	Provide service provider with door cycles and magnetron tube hours of operation	Press and the following will display: Door Cycles: Tube Hours:
<b>Software Version</b>	Displays the version of software and firmware installed in the control	Press and the following will display: SW: EE: App:
<b>Magnetron 1 Right Side</b>	System can be started and stopped by pressing the Start or Stop icon.	The current amperage being drawn by the HV system. 5 -12amps is considered normal. Look for consistent reading with Magnetron 2 and Convection Heater. This circuit is protected by fuse F3
<b>Magnetron 2 Left Side</b>	System can be started and stopped by pressing the Start or Stop icon	The current amperage being drawn by the HV system. 5 -12amps is considered normal. Look for consistent reading with Magnetron 1 and Convection Heater. This circuit is protected by fuse F4

<b>Both Magnetrons</b>	Both systems can be started and stopped by pressing the Start or Stop icon	The current amperage being drawn by BOTH HV systems. Look for consistent readings with Convection Heater. These are protected by Fuses F3 & F4.
<b>Convection Heater</b>	Heater can be stopped and started by pressing the Start Stop icon	The current amperage being drawn by the Convection Heater. 7-15 amps is considered normal. This circuit protected by fuse F5
<b>Radiant Heaters</b>	Not Used for this model	
<b>Convection Fan Low</b>	Convection Fan Motor Low Speed can be stopped and started by pressing the Start or Stop icon.	The current amperage being drawn by the Convection Fan Motor on low speed. <2 amps and fan motor operating noise is considered normal. This circuit is protected by fuse F2.
<b>Convection Fan High</b>	Convection Fan Motor High Speed can be stopped and started by pressing the Start or Stop icon.	The current amperage being drawn by the Convection Fan Motor on high speed. <3 amps and a high speed fan motor operating noise is considered normal.
<b>Cooling Fan</b>	Motors can be stopped and started by pressing the Start Stop icon.	The current amperage being drawn by both the Cooling Fan Motors. 1-3 amps is considered normal. A failed Cooling Fan motor will likely result in a G2 Error Code
<b>Antenna Motors</b>	Both Antenna Motors can be started by pressing the Start icon. NOTE: pressing Stop icon will not stop the antenna motors. They continue to run until Service Mode is exited.	DOES NOT OPERATE ON MRX UNITS: Antenna Motors draw very low amperage. It is normal to have 0 amps displayed. Service provider should visible inspect operation.
<b>RTD</b>	Resistive Thermal Devices (aka Temp Sensors) Press and the current temperature sensed by the RTD along with the maximum temperature recorded.	MRX OVENS ONLY HAVE ONE RTD AND MAXIMUM READING IS NOT USED. NON USED READING WILL BE 656 or 657– USE RADIANT RTD READING ONLY. The Radiant RTD is located at the back center of oven. The Convection RTD is located on the upper left by the Convection Element. To reset maximum temperature reading, press and hold the Max Convection RTD for several seconds—temperature will change to the current temperature sensed.
<b>Memory</b>	Attached Memory Devices	Press and the following will display: USB Present or Absent SD Card Present or Absent
<b>Error History</b>	Chronological List of Errors Experienced by the Control	Press and the following will display: Error Code Date, Time, and Code (see Error Code List in this section)
<b>Voltage Switching</b>	Displays the voltage as sensed by the control.	Pressing has no effect.
<b>Temperature Offset</b>	The degree of offset programmed into control to synchronize control to cavity temperature.	Press and the following will display: The amount of temperature offset programmed by the factory
<b>Pin Code</b>	Displays the 4 Digit Pin Code	Pressing has no effect.

# ERROR CODES

Code	Description	Corrective Action
<b>A2</b>	Invalid Display Firmware	Update Firmware or Replace Touch Control
<b>B1</b>	Touch Screen Error	Replace Touch Control
<b>B2</b>	Wifi Error	Reset Touch Control. If continued failure Replace Touch Control
<b>B3</b>	Wifi Error	Reset Touch Control. If continued failure Replace Touch Control
<b>D0</b>	Convect Temp Sensor (RTD)-Open	Replace Temp Sensor (Top Left of Oven)
<b>D1</b>	Convect Temp Sensor (RTD)-Shorted	Replace Temp Sensor (Top Left Oven)
<b>G0</b>	Oven Exceeded Max. or Min. Temperature	After oven cools, press the cavity thermal cutout's reset button found on the bottom, back right hand corner of oven. If unable to reset, Replace the Cavity Thermal Cutout. NOTE: Cutout may trip if subjected to sub-freezing temperatures
<b>G2</b>	Open Magnetron TCO	Board Senses an Open Magnetron TCO. Inspect Cooling Fans Operation and Airflow, TCO's and Wiring.
<b>H0</b>	Zero Cross Failure	No or Intermittent Voltage at J1 Connector on Main Control Board.
<b>H2</b>	Invalid System State	Main Control Board
<b>H3</b>	Invalid EEPROM/FLASH	Main Control Board
<b>I1</b>	Current Sense-No/Low Amps from Microwave Circuit	Perform Service Test (Magnetron #1 & #2) Suspect Door Switches not fully activated or weak door hinges. Secondary/Monitor Switch assembly is adjustable.
<b>V0</b>	Low Voltage	<188vac Detected by the Main Control Board
<b>V1</b>	High Voltage	>263vac Detected by the Main Control Board

**Important Note:** Error Code History cannot be cleared. Oldest codes will automatically be deleted when the history log is full.

# MICROWAVE POWER TEST

## Power Test

All ACP microwave oven power outputs are rated using the IEC705 standards. Using the IEC705 test method requires precision measurements and equipment that is not practical to be performed in the field. Using the test shown below will indicate if the oven performance is satisfactory.

### Set Up for Power Test

1. The oven MUST BE at room temperature for best results
2. Service Test Mode "Both Magnetrons"

### Test equipment required:

1000 ml test container and thermometer.

### Procedure

Fill the test container to the 1000 ml line with cool tap water as close to 60° F / 16° C as possible.

Using the thermometer, stir water for ten seconds; measure, and record the temperature.

Place test container of water in the center of oven cavity and close door.

Heat the water for a 33-second full power cycle.

At end of the cycle, remove test container. Using the thermometer, stir water for ten seconds and record temperature.

Subtract the starting water temperature from the ending water temperature to obtain the temperature rise. If the temperature rise meets or exceeds the nominal microwave energy rating found on the model/serial tag, the test is complete. If the temperature rise fails to meet the minimum temperature rise, test the line voltage to verify it is correct. Then repeat steps 1-6 making sure to change the water. If the temperature rise fails to meet the minimum temperature rise again the oven will require service.

**Minimum Temperature Rise at Thirty -Three (33) Seconds Run Time**

$\Delta T$ (°F)	Cooking Power Output	$\Delta T$ (°F)	Cooking Power Output	$\Delta T$ (°C)	Cooking Power Output	$\Delta T$ (°C)	Cooking Power Output
10 .....	1000	20 .....	2000	5 .....	1000	11 .....	2000
11 .....	1100	21 .....	2100	5.5 .....	1100	11.5 .....	2100
12 .....	1200	22 .....	2200	6.5 .....	1200	12 .....	2200
14 .....	1400	24 .....	2400	7.5 .....	1400	13 .....	2400
17 .....	1700	25 .....	2500	9.5 .....	1700	13.5 .....	2500
18 .....	1800	27 .....	2700	10 .....	1800	15 .....	2700
19 .....	1900	30 .....	3000	10.5 .....	1900	16.5 .....	3000

### Important Notes:

Low line voltage will cause low temperature rise / power output. Ovens must be on a dedicated circuit, properly grounded, and polarized. Other equipment on the same circuit may cause a low temperature rise / power output. This test and results are not a true IEC705 test procedure and are only intended to provide servicers with an easy means of determining if the microwave oven cooking output is correct.

# CONTROL BOARD WIRING

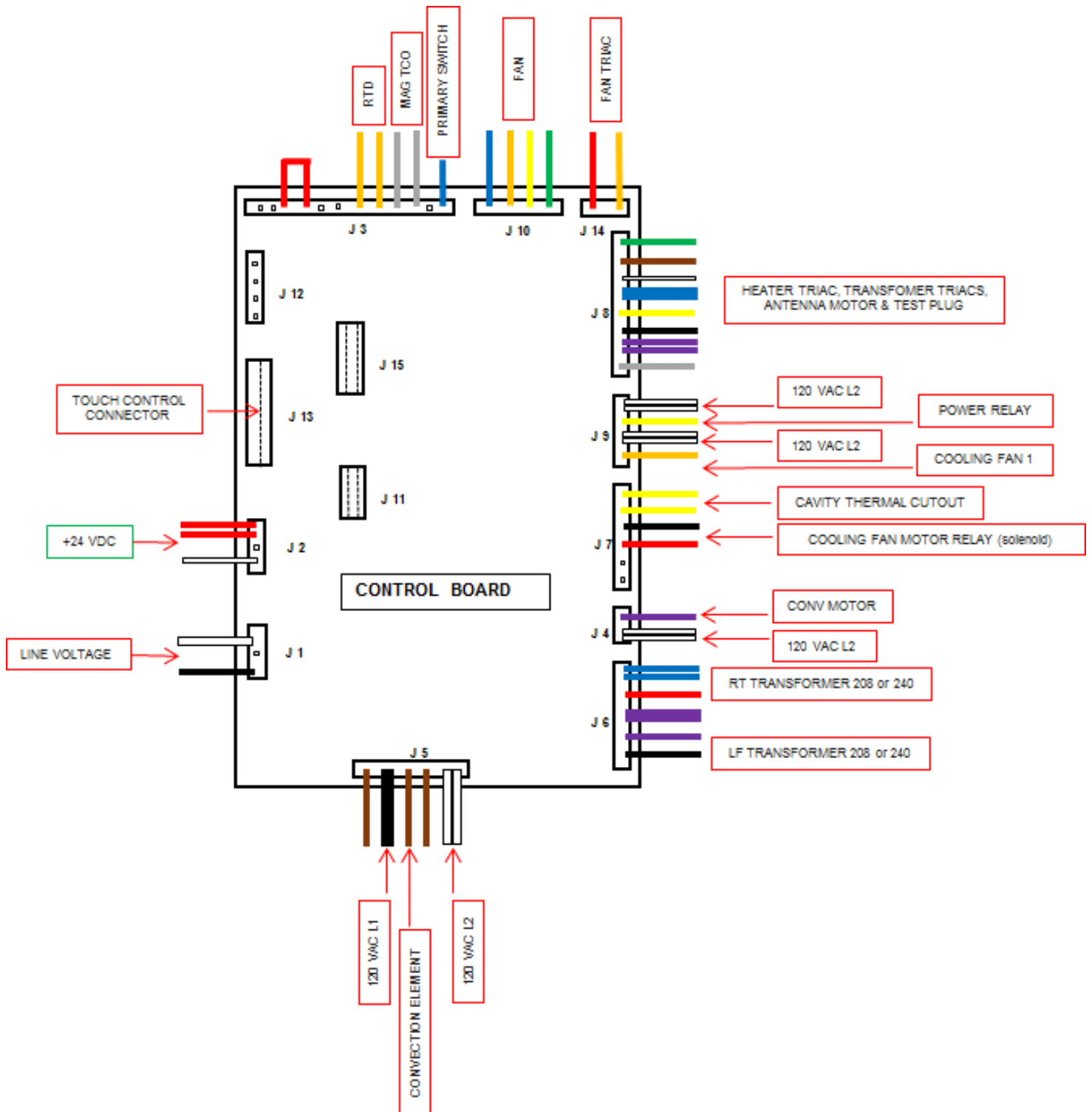

# SCHEMATICS & DIAGRAMS

