



# Service Training Manual

RFS Models



RFS - 60 Hz  
August 2011  
16400013

Amana® is a Registered Trademark of Maytag Corporation. Brand used under license.



# Table of Contents

Important Safety Information.....	1-5
RFS 60 Hz Specifications.....	6-8
Installation.....	7
Specifications.....	8
Quick Start Reference Guide.....	9-11
Components.....	12-13
Disassembly.....	14-16
Performance Testing Procedures.....	17-18
Component Testing Procedures .....	19-23
Troubleshooting.....	24-29
Schematic / Wiring Diagrams.....	30-35

# **1** | **Important Safety Information**

# Important Information

## Important Notices for Servicers and Consumers

ACP will not be responsible for personal injury or property damage from improper service procedures. Pride and workmanship go into every product to provide our customers with quality products. It is possible, however, that during its lifetime a product may require service. Products should be serviced only by a qualified service technician who is familiar with the safety procedures required in the repair and who is equipped with the proper tools, parts, testing instruments and the appropriate service information. IT IS THE TECHNICIAN'S RESPONSIBILITY TO REVIEW ALL APPROPRIATE SERVICE INFORMATION BEFORE BEGINNING REPAIRS.

 <b>WARNING</b>
To avoid risk of severe personal injury or death, disconnect power before working/servicing on appliance to avoid electrical shock.

To locate an authorized servicer please contact:

ComServ Support Center



Web Site  
WWW.ACPSOLUTIONS.COM

Telephone Number  
..... 1-866-426-2621 or 319-368-8195

E-Mail: [commercialservice@acpsolutions.com](mailto:commercialservice@acpsolutions.com)

Recognize Safety Symbols, Words, and Labels

 <b>DANGER</b>
---

DANGER— Immediate hazards which WILL result in severe personal injury or death.

 <b>WARNING</b>
--

WARNING— Hazards or unsafe practices which COULD result in severe personal injury or death.

 <b>CAUTION</b>
--

CAUTION— Hazards or unsafe practices which COULD result in minor personal injury, product or property damage.

# Important Safety Information



## WARNING

Read the following information to avoid possible exposure to microwave radiation:

The basic design of the Microwave Oven makes it an inherently safe device to both use and service.

However, there are some precautions which should be followed when servicing the microwave to maintain this safety. These are as follows:

1. Always operate the unit from an adequately grounded outlet. Do not operate on a two-wire extension cord.
2. Before servicing the unit (if unit is operable) perform the microwave leakage test.
3. The oven should never be operated if the door does not fit properly against the seal, the hinges or hinge bearings are damaged or broken; the choke is damaged, (pieces missing, etc.); or any other visible damage can be noted. Check the choke area to ensure that this area is clean and free of all foreign matter.
4. If the oven operates with the door open and produces microwave energy, take the following steps:
  - A. Tell the user not to operate the oven.
  - B. Contact ACP ComServ immediately.
5. Always have the oven disconnected when the outer case is removed except when making the "live" tests called for in the Service Manual. Do not reach into the equipment area while the unit is energized. Make all connections for the test and check them for tightness before plugging the cord into the outlet.
6. Always ground the capacitors on the magnetron filter box with an insulated-handle screwdriver before working in the high voltage area of the equipment compartment. Some types of failures will leave a charge in these capacitors and the discharge could cause a reflex action which could make you injure yourself.
7. Always remember that in the area of the transformer there is HIGH VOLTAGE. When the unit is operating keep this area clear and free of anything which could possibly cause an arc or ground, etc.
8. Do not for any reason defeat the interlock switches there is not valid reason for this action at any time; nor will it be condoned by ACP.
9. IMPORTANT: Before returning a unit to a customer, be sure to check for proper switch interlock action.
10. The Microwave Oven should never be operated with any components removed and/or bypassed or when any of the safety interlocks are found to be defective, or when any of the seal surfaces are defective, missing, or damaged.
11. All microwave ovens meet all requirements of the radiation control for Health and Safety Act of 1968. Due to measurement uncertainties, the maximum leakage for the field will be  $4\text{mw}/\text{cm}^2$ .
12. To ensure that the unit does not emit excessive microwave leakage and to meet the Department of Health and Human Services guidelines, check the oven for microwave leakage using a microwave oven leakage meter that complies with US Government CDRH / FDA / DHHS requirements and or any other local government requirements. The maximum leakage level allowed by ACP is  $4\text{mw}/\text{cm}^2$ .
13. If servicer encounters an emission reading over  $4\text{mw}/\text{cm}^2$ , the servicer is to cease repair and contact the ACP ComServ Department immediately for further direction. ACP will contact the proper Government Agency upon verification of the test results.

# IMPORTANT SAFETY INSTRUCTIONS



Recognize this symbol as a **SAFETY** message



## WARNING

When using electrical equipment, basic safety precautions should be followed to reduce the risk of burns, electrical shock, fire, or injury to persons including the following.

1. READ all instructions before using equipment.
2. READ AND FOLLOW the specific “PRECAUTIONS TO AVOID POSSIBLE EXPOSURE TO EXCESSIVE MICROWAVE ENERGY” on this page.
3. This equipment **MUST BE GROUNDED**. Connect only to properly GROUNDED outlet. See “GROUNDING / EARTHING INSTRUCTIONS” on page 5.
4. Install or locate this equipment **ONLY** in accordance with the installation instructions in this manual.
5. Some products such as whole eggs and sealed containers—for example, closed glass jars—are able to explode and **SHOULD NOT** be HEATED in this oven.
6. Use this equipment **ONLY** for its intended use as described in this manual. Do not use corrosive chemicals or vapors in this equipment. This type of oven is specifically designed to heat, cook, or dry food. It is not designed for industrial or laboratory use.
7. As with any equipment, **CLOSE SUPERVISION** is necessary when used by **CHILDREN**.
8. See door cleaning instructions on page A-4 of this owners manual.
9. **DO NOT** heat baby bottles in oven.
10. Baby food jars shall be open when heated and contents stirred or shaken before consumption, in order to avoid burns.
11. **DO NOT** operate this equipment if it has a damaged cord or plug, if it is not working properly, or if it has been damaged or dropped.
12. This equipment, including power cord, must be serviced **ONLY** by qualified service personnel. Special tools are required to service equipment. Contact nearest authorized service facility for examination, repair, or adjustment.
13. **DO NOT** cover or block louvers or other openings on equipment.
14. **DO NOT** store this equipment outdoors. **DO NOT** use this product near water – for example, near a kitchen sink, in a wet basement, a swimming pool, or a similar location.
15. **DO NOT** immerse cord or plug in water.
16. Keep cord **AWAY** from **HEATED** surfaces.
17. **DO NOT** let cord hang over edge of table or counter.
18. For commercial use only.

## PRECAUTIONS TO AVOID POSSIBLE EXPOSURE TO EXCESSIVE MICROWAVE ENERGY

- A. **DO NOT** attempt to operate this oven with the door open since open door operation can result in harmful exposure to microwave energy. It is important not to defeat or tamper with the safety interlocks.
- B. **DO NOT** place any object between the oven front face and the door to allow soil or cleaner residue to accumulate on sealing surfaces.
- C. **DO NOT** operate the oven if it is damaged. It is particularly important that the oven door close properly and that there is no damage to the:
  1. door (bent)
  2. hinges and latches (broken or loosened)
  3. door seals and sealing surfaces.
- D. The oven should not be adjusted or repaired by anyone except properly qualified service personnel.

## SAVE THESE INSTRUCTIONS

# IMPORTANT SAFETY INSTRUCTIONS



## WARNING

To avoid risk of fire in the oven cavity:

- a. DO NOT overcook food. Carefully attend oven when paper, plastic, or other combustible materials are placed inside the oven to facilitate cooking.
- b. Remove wire twist-ties from paper or plastic bags before placing bag in oven.
- c. If materials inside the oven ignite, keep oven door CLOSED, turn oven off and disconnect the power cord, or shut off power at the fuse or circuit breaker panel.
- d. DO NOT use the cavity for storage. DO NOT leave paper products, cooking utensils, or food in the cavity when not in use.



## WARNING

Liquids such as water, coffee, or tea are able to be overheated beyond the boiling point without appearing to be boiling due to surface tension of the liquid. Visible bubbling or boiling when the container is removed from the microwave oven is not always present. THIS COULD RESULT IN VERY HOT LIQUIDS SUDDENLY BOILING OVER WHEN A SPOON OR OTHER UTENSIL IS INSERTED INTO THE LIQUID. To reduce the risk of injury to persons:

- i) Do not overheat the liquid.
- ii) Stir the liquid both before and halfway through heating it.
- iii) Do not use straight-sided containers with narrow necks.
- iv) After heating, allow the container to stand in the microwave oven for a short time before removing the container.
- v) Use extreme care when inserting a spoon or other utensil into the container.



## CAUTION

To avoid personal injury or property damage, observe the following:

1. Do not deep fat fry in oven. Fat could overheat and be hazardous to handle.
2. Do not cook or reheat eggs in shell or with an unbroken yolk using microwave energy. Pressure may build up and erupt. Pierce yolk with fork or knife before cooking.
3. Pierce skin of potatoes, tomatoes, and similar foods before cooking with microwave energy. When skin is pierced, steam escapes evenly.
4. Do not operate equipment without load or food in oven cavity.
5. Microwave popcorn should not be popped in oven.
6. Do not use regular cooking thermometers in oven. Most cooking thermometers contain mercury and may cause an electrical arc, malfunction, or damage to oven.
7. Do not use metal utensils in oven.
8. Do not use aluminum foil in oven
9. Never use paper, plastic, or other combustible materials that are not intended for cooking.
10. When cooking with paper, plastic, or other combustible materials, follow manufacturer's recommendations on product use.
11. Do not use paper towels which contain nylon or other synthetic fibers. Heated synthetics could melt and cause paper to ignite.
12. Do not heat sealed containers or plastic bags in oven. Food or liquid could expand quickly and cause container or bag to break. Pierce or open container or bag before heating.
13. To avoid pacemaker malfunction, consult physician or pacemaker manufacturer about effects of microwave energy on pacemaker.
14. An authorized servicer MUST inspect equipment annually. Record all inspections and repairs for future use.

## SAVE THESE INSTRUCTIONS

# 2

## **RFS 60 Hz Specifications**

### **Installation**

- Unpacking the oven
- Radio Interference
- Oven Placement

### **Power Specification**

- Input- Power Source
- Output- Power Source
- Power Consumption

### **Cavity Dimensions**

- Weight

# Installation

## Unpacking Oven

- Inspect oven for damage such as dents in door or dents inside oven cavity.
- Report any dents or breakage to source of purchase immediately. Do not attempt to use oven if damaged.
- Remove all materials from oven interior.
- If oven has been stored in extremely cold area, wait a few hours before connecting power.

## Radio Interference

Microwave operation may cause interference to radio, television, or similar a oven. Reduce or eliminate interference by doing the following:

- Clean door and sealing surfaces of oven according to instructions in “Care and Cleaning” section.
- Place radio, television, etc. as far as possible from oven.
- Use a properly installed antenna on radio, television, etc. to obtain stronger signal reception.

## Oven Placement

- Do not install oven next to or above source of heat, such as pizza oven or deep fat fryer. This could cause microwave oven to operate improperly and could shorten life of electrical parts.
- Do not block or obstruct oven filter. Allow access for cleaning.
- Install oven on level countertop surface.

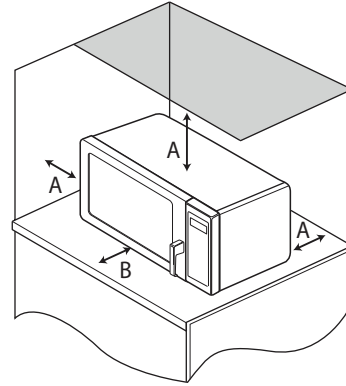

A—Allow at least 1½ inches / 3.81 centimeters of clearance around top and sides of equipment. Proper air flow around equipment cools electrical components. With restricted air flow, oven may not operate properly and life of electrical parts is reduced.

---

Oven Clearances

# Specifications

<b>Models</b>	<b>RFS12MPSB, RFS12SW2B, RFS12SW2C, RFS12TS(W)</b>	<b>RFS18MPS, RFS18TS</b>
<b>Power Source</b>		
Voltage AC	120V	208-240V
Amperage	20 A	20 A
Frequency	60 Hz	60 Hz
Single Phase, 3 wire grounded	X	X
Plug Configuration / Cord	NEMA 5-20	NEMA 6-20
<b>Power Output</b>		
Nominal microwave energy (IEC705)	1200 W	1800 W
Minimum temperature rise	12°F / 6.5°C	18°F / 7.7°C
Operating Frequency	2450 MHz	2450 MHz
<b>Power Consumption</b>		
Cook Condition Microwave	1800 W,	3000 W
<b>Dimensions</b>		
<b>Cabinet</b>		
Width	21¾" (550)	21¾" (550)
Height	14¼" (362)	14¼" (362)
Depth	20¼" (514)	20¼" (514)
<b>Cavity Dimensions</b>		
Width	14¼" (362)	14¼" (362)
Height	9" (226)	9" (226)
Depth	16 3/8" (416)	16 3/8" (416)
<b>Weight</b>		
Crated	71 lbs. (32 kg.)	73 lbs. (33 kg.)
Uncrated	64 lbs. (29 kg.)	67 lbs. (30 kg.)

# 3 | **RFS 60 Hz Quick Start Reference Guide**

## **Control Panel**

- Manual operation
- Programming items
- Qty 2X Pad

## **Clean Filter**

## **User Options**

- Changing options
- Factory presets

Refer to Product Safety Manual for Safety Statements  
Complete Owner's Manual available online

## CLEAN FILTER

This oven displays CLEAN FILTER at user defined intervals. When the message displays ACP recommends cleaning the air filter thoroughly. **Cleaning the air filter will not shut off the message.** The message will stop displaying automatically after 24 hours. Depending on microwave use and environmental conditions, the filter may need to be cleaned more frequently. Once the frequency is determined, set the option for the appropriate time frame.

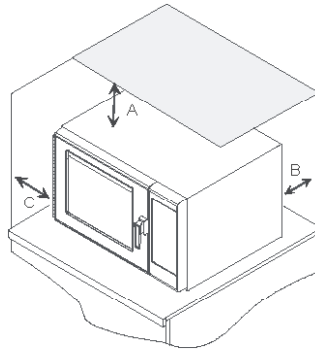

### Oven Wall Clearances

- A—For North American (UL/CSA) models, allow at least 2" (5.1 cm) of clearance around top of oven. For International (50 Hz) models, allow at least 12" (30 cm) of clearance around top of oven. Proper air flow around oven cools electrical components. With restricted air flow, oven may not operate properly and life of electrical parts is reduced.
- B—Allow at least 2" (5.1 cm) between air discharge on back of oven and back wall.
- C—Allow at least 2" (5.1 cm) of clearance around sides of oven.

## So...how do I use it? (Electronic Control)

7

### Preprogrammed Pads

To cook food using preprogrammed cooking sequences:

1. Open oven door and place food in oven. Close door.
2. Press desired pad.
3. Oven begins to cook.
4. At end of cooking cycle oven beeps and shuts off.

QTY  
2X

### QTY 2X Programming (some models)

To change the cooking factor:

1. Open oven door.
2. Press and hold pad 1 for approximately 5 seconds.
3. Press pad to be reprogrammed.
4. Press the QTY 2X pad.
5. Press a numbered pad to change the cooking factor.
  - Cooking factor can be set from 10% to 100%.
  - Default is 80%.
  - Pad 5 would change the cooking factor to 50%.
6. Press START pad to save changes.

### Manual Operation

To cook food using a specific entered time and power level:

1. Open oven door and place food in oven. Close door.
2. Press TIME ENTRY pad and enter cooking time.
3. Press a power level pad to change power level if desired (some models).
  - **COOK LEVEL** displays with the power setting.
4. If stage cooking is desired, press TIME ENTRY pad and repeat steps 2 through 4, (some models).
5. Press START pad.
6. At end of cooking cycle oven beeps and shuts off.

### Programming Items

1. Open oven door.
2. Press and hold pad 1 for approximately 5 seconds.
3. Press pad to be reprogrammed.
4. Enter cooking time by using the number pads.
5. Press a power level pad to change power level if desired.
6. If stage cooking is desired, press TIME ENTRY pad.
  - Display briefly shows the stage number.
  - Display changes to cook time and power level for the next stage.
7. Enter cook time and power level as in steps 4 and 5 (some models).
  - To enter another cooking stage for that pad, press TIME ENTRY pad again.
  - Up to four different stages can be programmed (some models).
8. Press START pad to set new programming changes to the pad.

**NOTE:** To discard changes, press STOP/RESET pad or close oven door.

### QTY 2X Pad (some models)

1. Open oven door and place food in oven. Close door.
2. Press QTY 2X pad.
3. Press desired preprogrammed pad or pad sequence.
4. Oven begins cooking. Displayed cooking time is the total of original cooking time and added 2X time.

The switching operation of this microwave oven can cause voltage fluctuations on the supply line. The operation of this oven under unfavorable voltage supply conditions can have adverse effects. This device is intended for the connection to a power supply system with a maximum permissible system impedance  $Z_{max}$  of **0.2 Ohms** at the interface point of the user's supply. The user has to ensure that this device is connected only to a power supply system which fulfills the requirement above. If necessary, the user can ask the public power supply company for the system impedance at the interface point.

# Quick Start Reference Guide

Refer to Product Safety Manual for Safety Statements  
Complete Owner's Manual available online

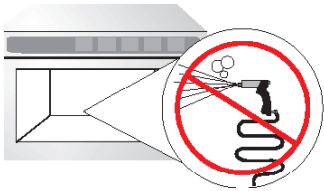

**DO NOT power spray**

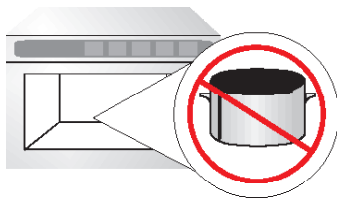

**No metal pans**

## ? Can I change an option?

Options such as single or double pad programming, beep volume, and maximum cooking time can be changed to suit individual preferences.

To change options:

1. Open oven door.
  - If door is closed or RESET pad is pressed before programming is complete, changes are discarded and microwave exits programming mode.
2. Press and hold pad 2 for approximately 5 seconds.
  - This begins options mode.
  - Microwave will beep and OP: displays.
3. Press number pad that controls option to be changed.
  - See table below for options.
  - Current option will display.
4. Press number pad again to change the option.
  - Each time pad is pressed, option will change.
  - Match code displayed with code for desired option.
5. Press START pad to save changes.
  - To change additional options, repeat steps 3 and 4.
  - Changes appear after door is closed or STOP/RESET pad is pressed.

Numbered Pads	Display	Options
1 End of Cycle Beep	OP:10	3 second beep.
	OP:11	Continuous beep until door is opened.
	OP:12	5 beep bursts until door is opened.
2 Key Beep Volume	OP:20	Eliminates beep.
	OP:21	Sets volume to low.
	OP:22	Sets volume to medium.
	OP:23	Sets volume to high.
3 Key Beep	OP:30	Prevents beep when pad is pressed.
	OP:31	Allows beep when pad is pressed.
4 Active Display	OP:40	15 seconds after oven door is opened, keyboard disabled.
	OP:41	30 seconds after oven door is opened, keyboard disabled.
	OP:42	1 minute after oven door is opened, keyboard disabled.
	OP:43	2 minutes after oven door is opened, keyboard disabled.
5 On-the Fly Cooking	OP:50	Prevents different pre-programmed pads to be activated during cooking.
	OP:51	Allows different pre-programmed pads to be activated during cooking.
6 Reset to Ready Mode	OP:60	Opening oven door does not reset oven back to ready mode.
	OP:61	Opening oven door resets oven back to ready mode.
7 (some models) Maximum Heating Time	OP:70	Allows 60 minutes of heating time (some models).
	OP:71	Allows 10 minutes of heating time.
8 Manual Operation	OP:80	Allows use of preprogrammed pads only.
	OP:81	Allows use of manual time entry and preprogrammed pads.
9 (some models) Double Digit Operation	OP:90	Allows 10 (0-9) preprogrammed pads.
	OP:91	Allows 100 (00-99) preprogrammed pads.
0 Clean Filter Message	OP:00	Do not display message.
	OP:01	Display message for 24 hours every 7 days.
	OP:02	Display message for 24 hours every 30 days.
	OP:03	Display message for 24 hours every 90 days.

# **4** | **RFS 60 Hz Components Location**

# Components Location

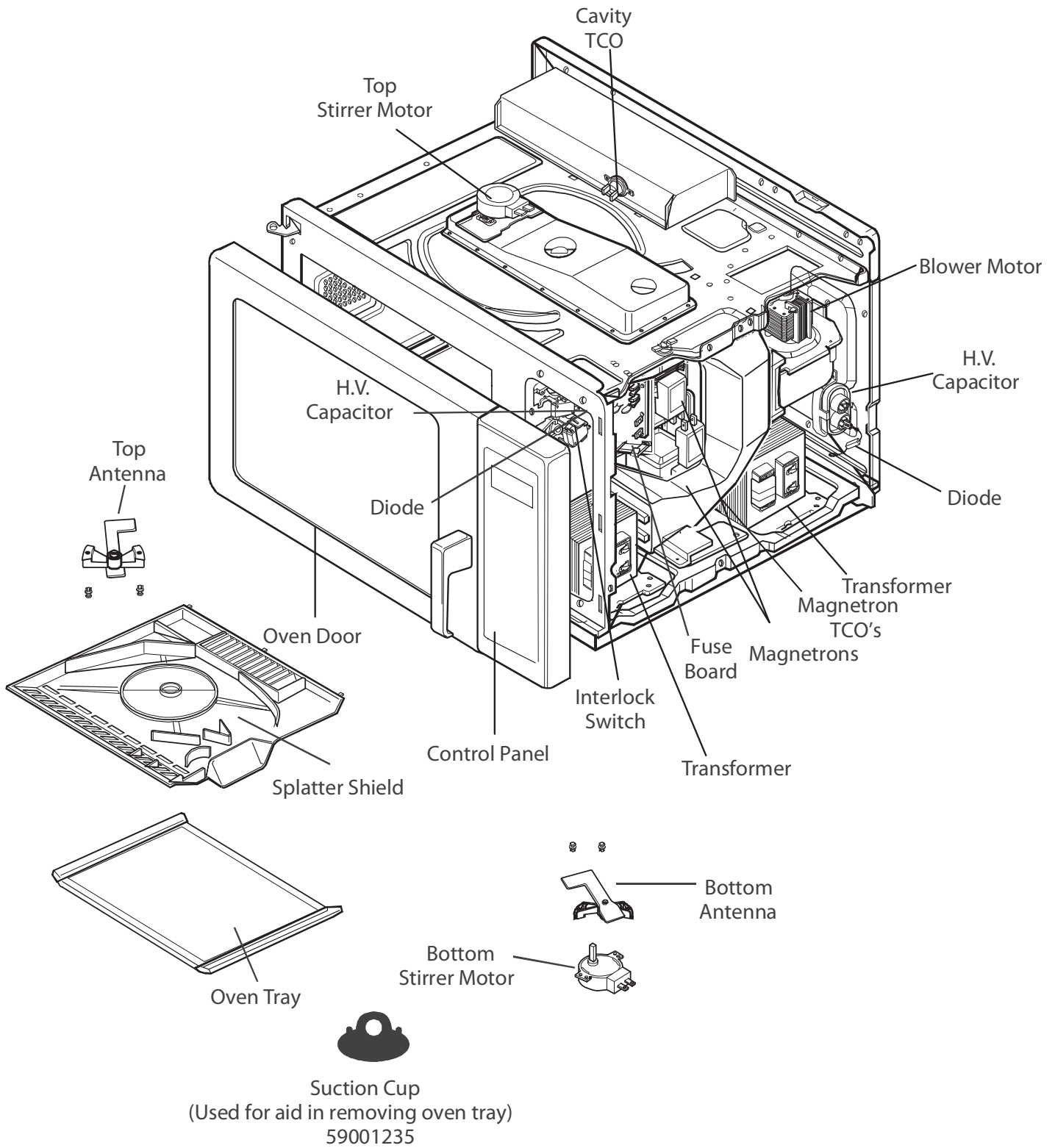

# 5 | **Disassembly**

## **Door removal**

- Disassembly

## **Control panel removal**

- Wire terminals

# Disassembly

## Door Removal

1. Disconnect power to oven.
2. Open oven door, remove top hinge cap, and slowly lift door to disengage the hinge pins at top and bottom.

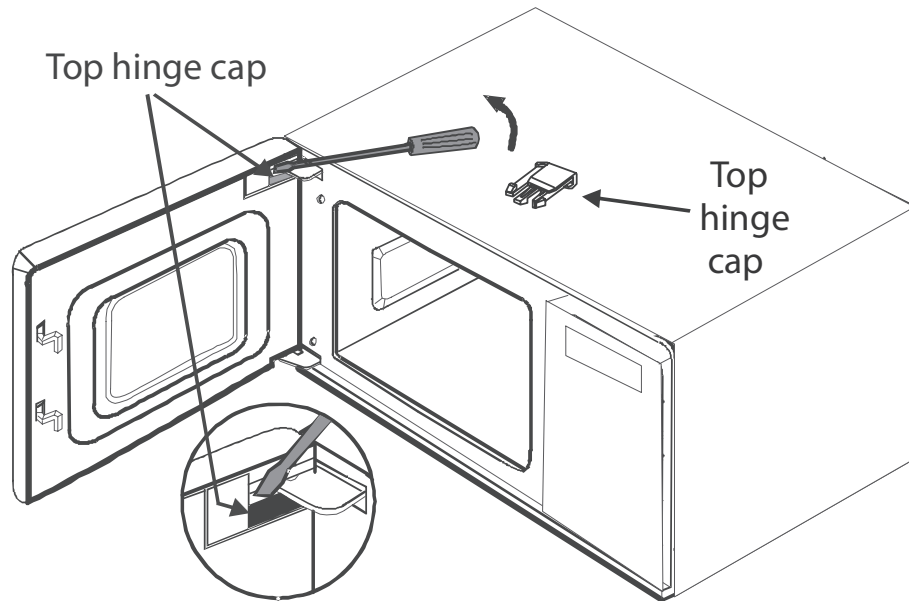

3. To reinstall door, place top pin into slot first, then align bottom pin.
4. Reinstall top hinge cap.

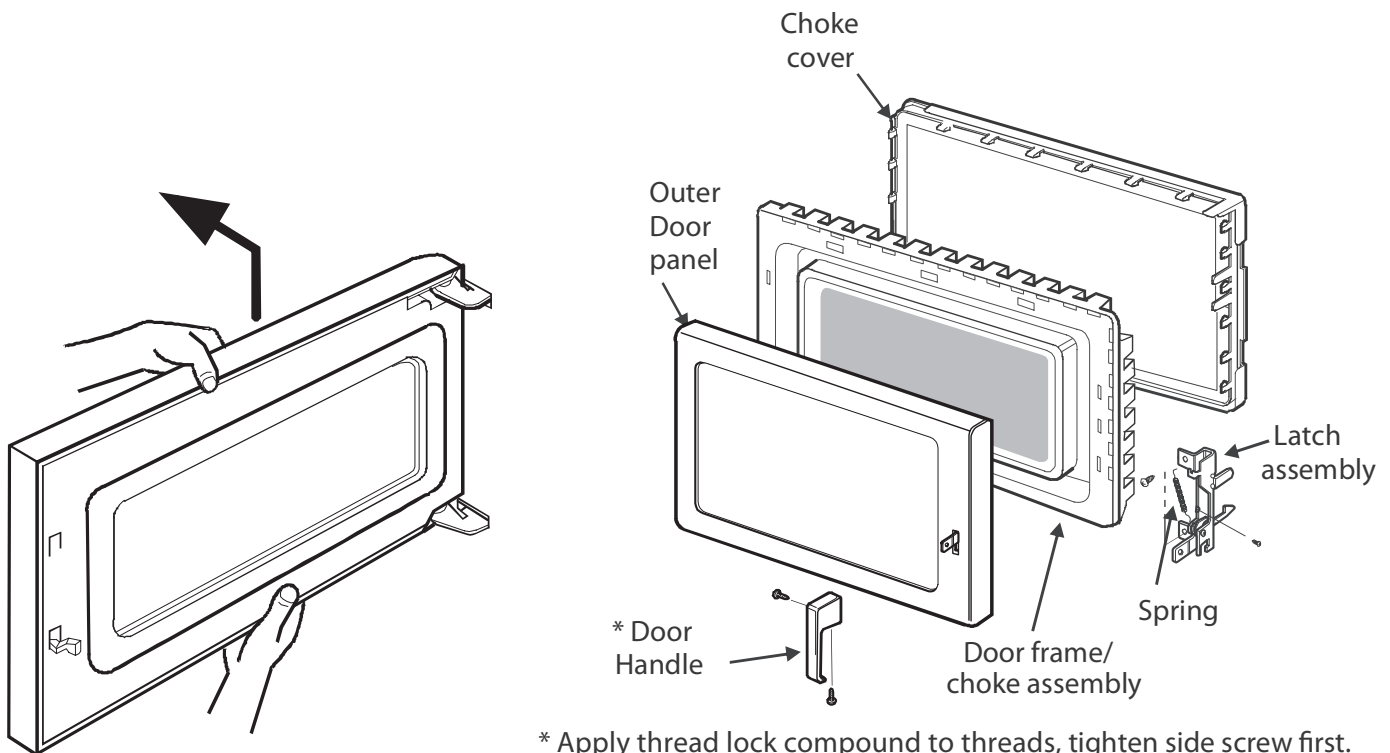

# Disassembly

## Control Panel Removal

1. Disconnect power to oven and remove outer case.
2. Disconnect and label wires from controller/timer.
3. Open oven door.
4. Remove screw securing top of control panel to cavity. Lift control panel up and out to release tabs.

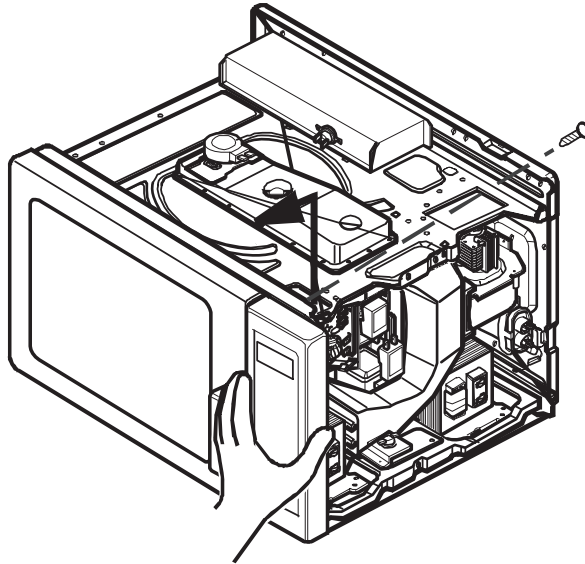

## Disconnecting Wire Terminals

All wire terminals are locking-type terminals.

Proceed as follows to disconnect wire terminals:

Insulated terminals:

Grasp insulator pod and pull back. **DO NOT PULL ON WIRE.**

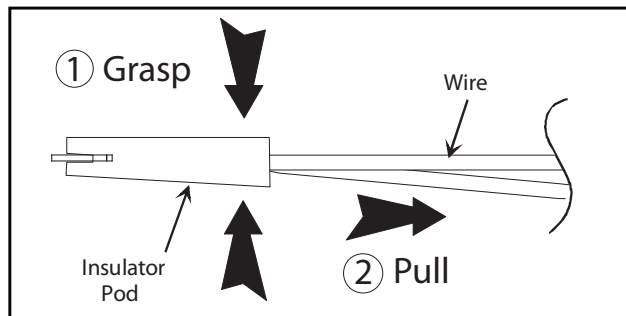

Non-insulated terminals:

Use a small blade screwdriver to depress locking-tab and pull on terminal. **DO NOT PULL ON WIRE.**

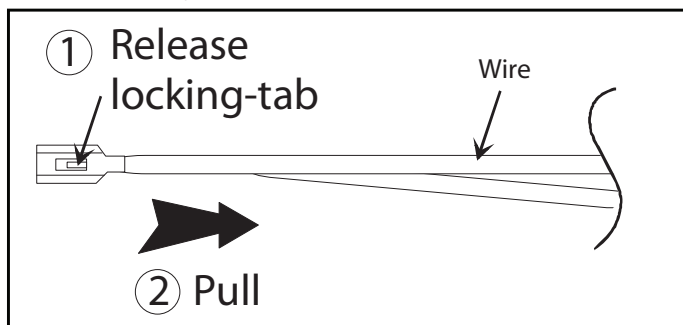

# 6 | Performance Testing Procedures

# Performance Testing Procedures



## WARNING

To avoid risk of electrical shock, personal injury or death, disconnect power to oven and discharge capacitor before servicing, unless testing requires it.

All Amana and Menumaster microwave oven power outputs are rated using the IEC705 standards. Using the IEC705 test method requires precision measurements and equipment that is not practical to be performed in the field. Using the test shown below will indicate if the oven performance is satisfactory.

### Test equipment required:

- 1000 ml test container and thermometer.
- Digital watch / watch with a second hand for use on ovens with electromechanical timers.

### Important Notes:

- Low line voltage will cause low temperature rise / power output.
- Ovens must be on a dedicated circuit, properly grounded, and polarized. Other equipment on the same circuit may cause a low temperature rise / power output.
- This test and results are not a true IEC705 test procedures and are only intended to provide servicers with an easy means of determining if the microwave oven cooking output is correct.

### Procedure

1. Fill the test container to the 1000 ml line with cool tap water.

**NOTE:** Water temperature should be approximately 60°F / 16°C

2. Using the thermometer, stir water for five to ten seconds; measure, and record the temperature (T1).
3. Place test container of water in the center of oven cavity and close door.
4. Heat the water for a 33-second full power cycle.

**NOTE:** Use a digital watch or a watch with a second hand for ovens with electromechanical timers.

5. At end of the cycle, remove test container. Using the thermometer, stir water for five to ten seconds and record temperature (T2).
6. Subtract the starting water temperature (T1), from the ending water temperature (T2) to obtain the temperature rise ( $\Delta T$ ).
7. If the temperature rise ( $\Delta T$ ) meets or exceeds the minimum, the test is complete. If the temperature rise ( $\Delta T$ ) fails to meet the minimum temperature rise, test the line voltage to verify it is correct. Then repeat steps 1 - 6 making sure to change the water. If the temperature rise ( $\Delta T$ ) fails to meet the minimum temperature rise again the oven will require service.

### Minimum Temperature Rise at Thirty -Three (33) Seconds Run Time





$\Delta T$ (°F)	Cooking Power Output	$\Delta T$ (°F)	Cooking Power Output	$\Delta T$ (°C)	Cooking Power Output	$\Delta T$ (°C)	Cooking Power Output
10 .....	1000	20 .....	2000	5 .....	1000	11 .....	2000
11 .....	1100	21 .....	2100	5.5 .....	1100	11.5 .....	2100
12 .....	1200	22 .....	2200	6.5 .....	1200	12 .....	2200
14 .....	1400	24 .....	2400	7.5 .....	1400	13 .....	2400
17 .....	1700	25 .....	2500	9.5 .....	1700	13.5 .....	2500
18 .....	1800	27 .....	2700	10 .....	1800	15 .....	2700
19 .....	1900	30 .....	3000	10.5 .....	1900	16.5 .....	3000

# **7** | **Component Testing Procedures**

# Component Testing Procedures

## ⚠ WARNING

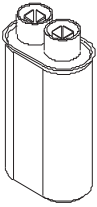
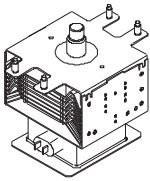
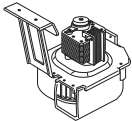
To avoid risk of electrical shock, personal injury or death, disconnect power to oven and discharge capacitor before servicing, unless testing requires it.

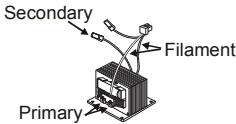
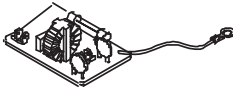
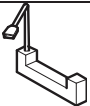
Illustration	Component	Testing	Results
	Thermal cutout	Disconnect all wires from TCO. Measure resistance across terminals. Cavity TCO .....  Magnetron TCO .....	Opens at 230°F (110°C)  Closed at 140°F (60°C) and Opens at 320°F (160°C)
	Diode	<b>Discharge Capacitor</b>  Remove diode lead from capacitor and connect ohmmeter.  Reverse leads for second test.	Infinite resistance should be measured in one direction and 50KΩ or more in the opposite direction.  <b>NOTE:</b> Ohmmeter must contain a battery of 6 volts minimum.
	Capacitor	<b>Discharge Capacitor</b>  Remove wires from capacitor terminals and connect ohmmeter, set on highest resistance scale to terminals.  Also check between each terminal and capacitor case.	Between Terminals: Meter should momentarily deflect towards zero then return to over 5 MΩ. If no deflection occurs, or if continuous deflection occurs, replace capacitor.  Terminal to Case: Infinite resistance
	Magnetron	<b>Discharge Capacitor</b>  Remove wires from magnetron and connect ohmmeter to terminals. Also check between each terminal and ground.	Between Terminals: Less than 1 Ω  Each terminal to ground measures Infinite resistance. <b>Note:</b> This test is not conclusive. If oven does not heat and all other components test good replace the magnetron and retest.
	Blower motor	Remove all wires from motor.  Measure resistance across coil .....	Approximately 28 – 35 Ω
	Stirrer motor	Remove all wires from motor.  Measure resistance across terminals .....	Approximately 12 – 14 KΩ
	Transformer	<b>Discharge Capacitor</b> Remove all wires from terminals.  Measure resistance from: Primary ..... Filament..... Secondary to Ground screw on transformer stack.....	Less than <1 Ω Less than <1 Ω  Approximately 90-100 Ω
	Noise filter board	Power In terminals ..... Power Out terminals ..... Power In terminals ..... Power Out terminals .....	120 VAC (RFS12) 120 VAC (RFS12) 240 VAC (RFS18) 240 VAC (RFS18)  If no power in, check power outlet. If no power out, check fuses.
	Circuit Protector	Measure resistance across terminals .....	Between Terminals: Less than 1 Ω

# Component Testing Procedures



## WARNING

To avoid risk of electrical shock, personal injury or death, disconnect power to oven and discharge capacitor before servicing, unless testing requires it.

Illustration	Component	Testing	Results
	<b>Interlock switch assembly</b> 	Disconnect wires to switch.  With door open measure resistance from: Top Monitor – COM (PK) – NO (BL)..... Btm Monitor – COM (WH) – NO (RD)..... Top Primary – COM (RD BK) – NC (BN) Btm Primary – COM (BK) – NC (BL)..... Secondary – COM (PK) – NC (GN).....  With door closed measure resistance from: Top Monitor – COM (PK) – NO (BL)..... Btm Monitor – COM (WH) – NO (RD)..... Top Primary – COM (RD BK) – NC (BN) Btm Primary – COM (BK) – NC (BL)..... Secondary – COM (PK) – NC (GN).....  <b>After verifying or replacing the module, reconnect wires to switch and check operation of monitor circuit before operating the oven.</b>	Indicates continuity Indicates continuity Infinite $\Omega$ Infinite $\Omega$ Infinite $\Omega$  Infinite $\Omega$ Infinite $\Omega$ Indicates continuity Indicates continuity Indicates continuity
	Lamp receptacle	Test continuity of receptacle terminals.	Indicates continuity with bulb installed.
	Wire Harness	Test continuity of wires	Indicates continuity

Electronic Control Panel			
	<b>Service Test Mode:</b>	<b>Open door, Press and Hold pad 3 for 5 seconds to enter service test mode.</b> Press Pad 1.....  Press Pad 2.....  Press Pad 3..... Press Pad 4.....  Press Pad 5..... Press Pad 6.....  Press Pad 7..... Press Pad 8..... Press Pad 9..... Press Pad 0..... Stop/Reset Pad .....	SERVICE appears in the display  Indicates number of hours magnetron has been turned on Indicates number of times magnetron tube has been turned on and off Indicates number of door cycles CLEAR (Press START pad to reset service data.) Indicates amperage (Top Mag) Indicates amperage (Bottom Mag)  RESET (Clear Service Alarm) N/A N/A N/A Exit Service Test Mode
	<b>Error codes:</b>	<b>E-08</b> ..... <b>E-09</b> ..... <b>E-10</b> .....	Replace Control Board Replace Control Board Shorted or Open Keypad – Test and replace if necessary

# Component Testing Procedures RFS12\*

## ! WARNING

To avoid risk of electrical shock, personal injury or death, disconnect power to oven and discharge capacitor before servicing, unless testing requires it.

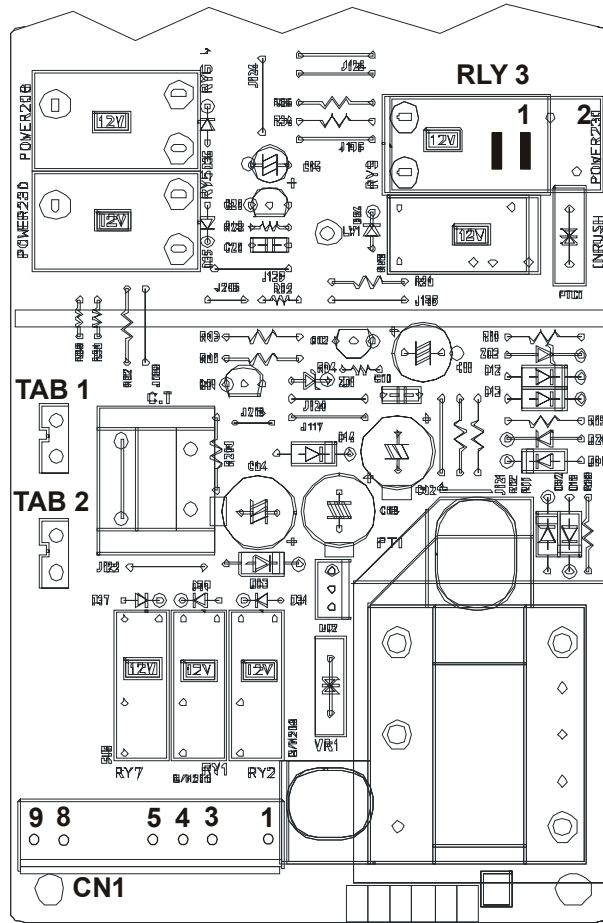

Function	Test Set-Up / Condition	Meter Setting	Probe Placement	Results
Power to current transformer	All Conditions	Volts	Tab 1 to CN1 Pin 3 (Neutral)	120 VAC
Power from current transformer	All Conditions	Volts	Tab 2 to CN1 Pin 3 (Neutral)	120 VAC
Power from Oven TCO	All Conditions	Volts	CN1 – Pin 1 (Black wire to Neutral)	120 VAC
Power to Oven Light	Standby .....	Volts	CN1 – Pin 4 to Pin 1 .....	120 VAC
	Ready .....	Volts	CN1 – Pin 4 to Pin 1 .....	0 VAC
	Cook .....	Volts	CN1 – Pin 4 to Pin 1 .....	0 VAC
Power to Blower Motor	Standby .....	Volts	CN1 – Pin 5 to Pin 1 .....	120 VAC
	Ready .....	Volts	CN1 – Pin 5 to Pin 1 .....	0 VAC
	Cook .....	Volts	CN1 – Pin 5 to Pin 1 .....	0 VAC
Secondary Interlock Switch	Door Closed .....	Ohms	CN1 – Pin 8 to Pin 9 .....	Continuity
	Door Opened .....	Ohms	CN1 – Pin 8 to Pin 9 .....	Infinite
Power to Relay 3	Standby .....	Volts	Relay 3 – Pin 1 to Pin 2 .....	120 VAC
	Ready .....	Volts	Relay 3 – Pin 1 to Pin 2 .....	120 VAC
	Cook .....	Volts	Relay 3 – Pin 1 to Pin 2 .....	0 VAC



# 8 | Troubleshooting

# Troubleshooting

WHEN YOU GET A COMPLAINT FROM YOUR CUSTOMER, EVALUATE THE COMPLAINT CAREFULLY. IF THE FOLLOWING SYMPTOMS APPLY, PLEASE INSTRUCT THE CUSTOMER IN THE PROPER USE OF THE MICROWAVE OVEN. THIS CAN ELIMINATE AN UNNECESSARY SERVICE CALL.

1. Check grounding before checking for trouble.
2. Be careful of the high voltage circuit.
3. Discharge the high voltage capacitor.
4. When checking the continuity of the switches or of the high voltage transformer, disconnect one lead wire from these parts and then check continuity with the AC plug removed. To do otherwise may result in a false reading or damage to your meter.
5. Do not touch any part of the circuit on the PCB since static electric discharge may damage this control panel.  
Always touch yourself to ground while working on this panel to discharge any static charge built up in your body.

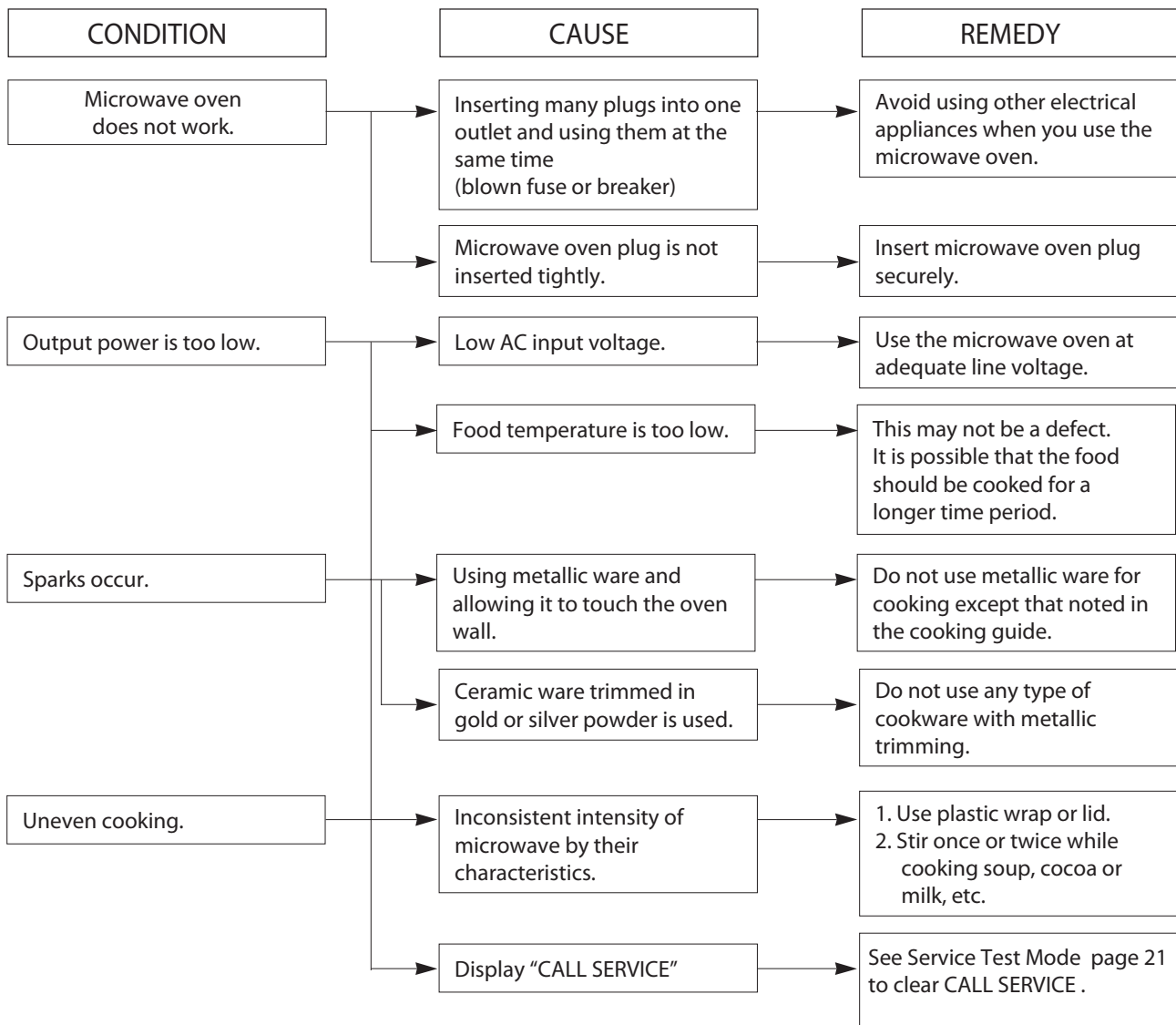

# Troubleshooting

**Trouble 1:** The following visual conditions indicate a probable failed control circuit.

1. Incomplete segments.
  - Segment missing.
  - Partial segment missing.
  - Digit flickering (Note: Slight flickering is normal.)
2. Colon does not turn on or blink.
3. A distinct change in the brightness of one or more numbers in display.
4. One or more digits in the display are not lighting.
5. Display indicates a number different from one touched, for example, key in 5 and 3 appears in the display.
6. Specific numbers (for example 7 or 9) will not display when key pad is touched.
7. Display does not count down with time blinking or up with clock operation.
8. Display obviously jumps in time while counting down.
9. Display counts down too fast while cooking.
10. Each indicator light does not turn on after setting cooking cycle.
11. Display time of day does not reappear when cooking is finished.

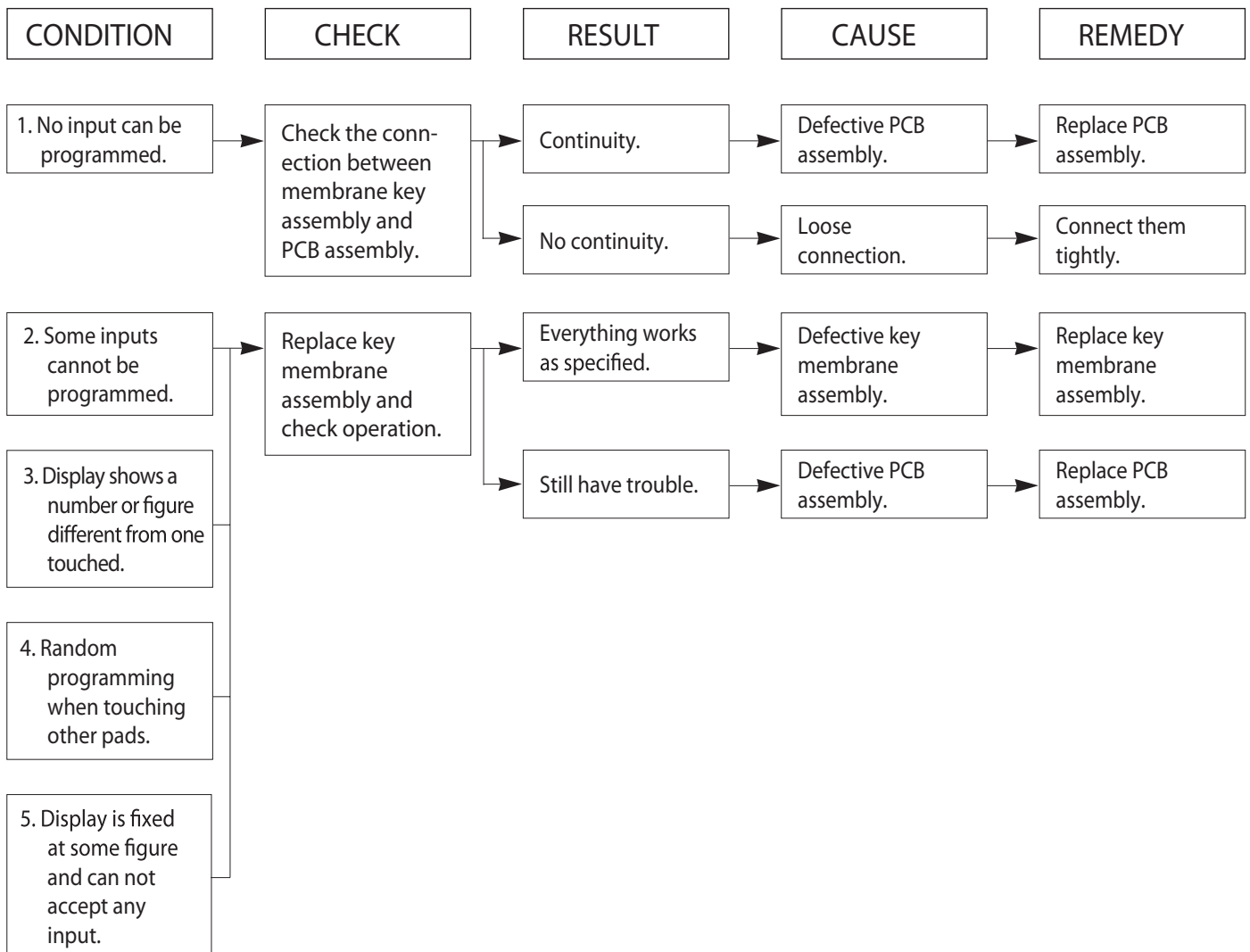

# Troubleshooting

**Trouble 2:** Oven does not operate at all, Display window does not display any figures, and no input is accepted.

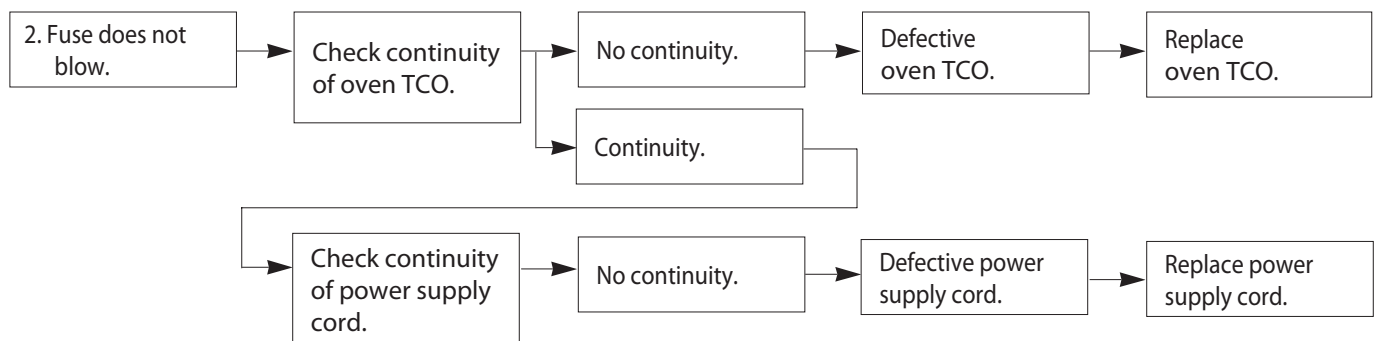
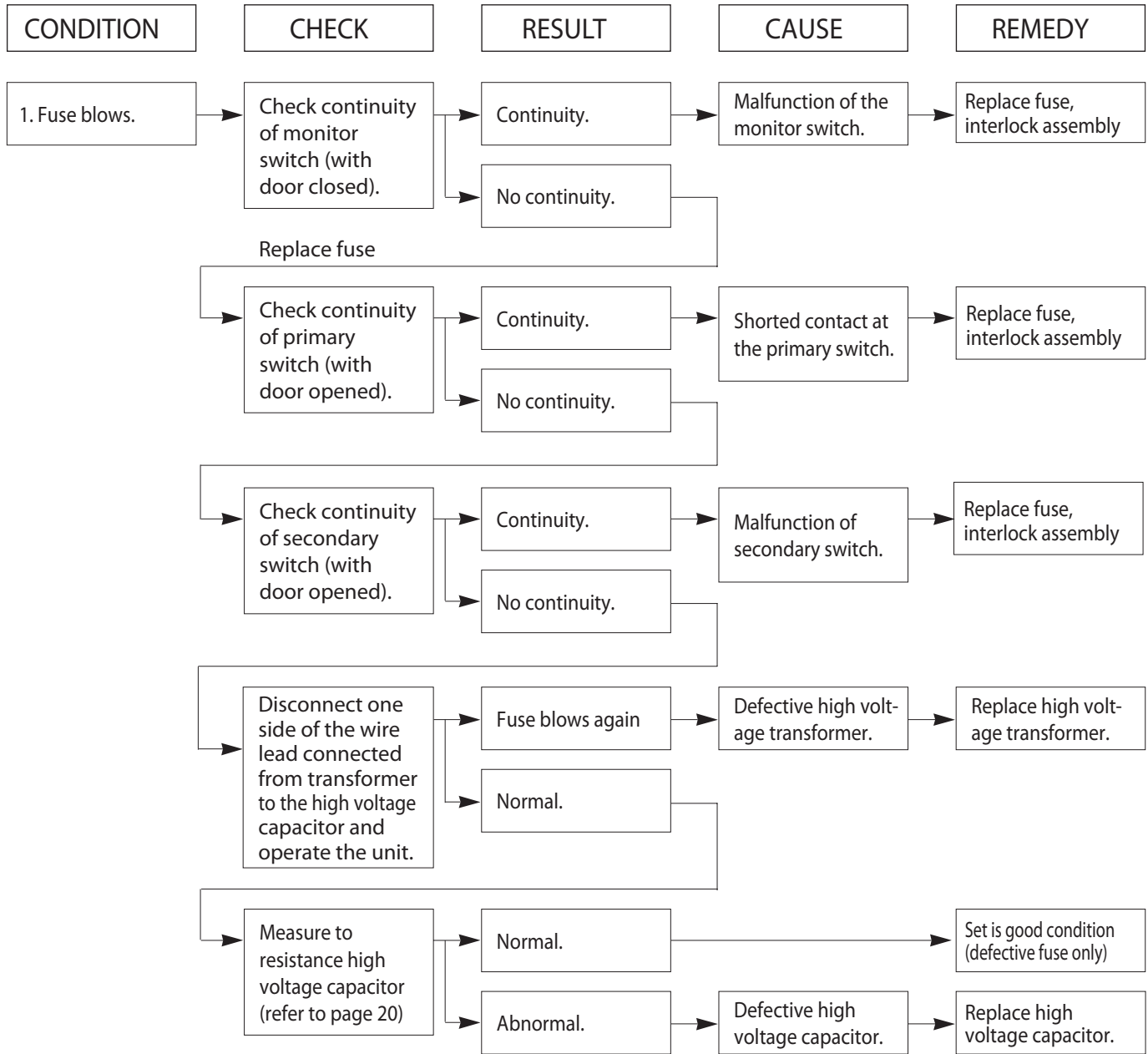

# Troubleshooting

**Trouble 3:** Display shows all figures set, but oven does not start cooking while desired program times are set and START pad is touched.

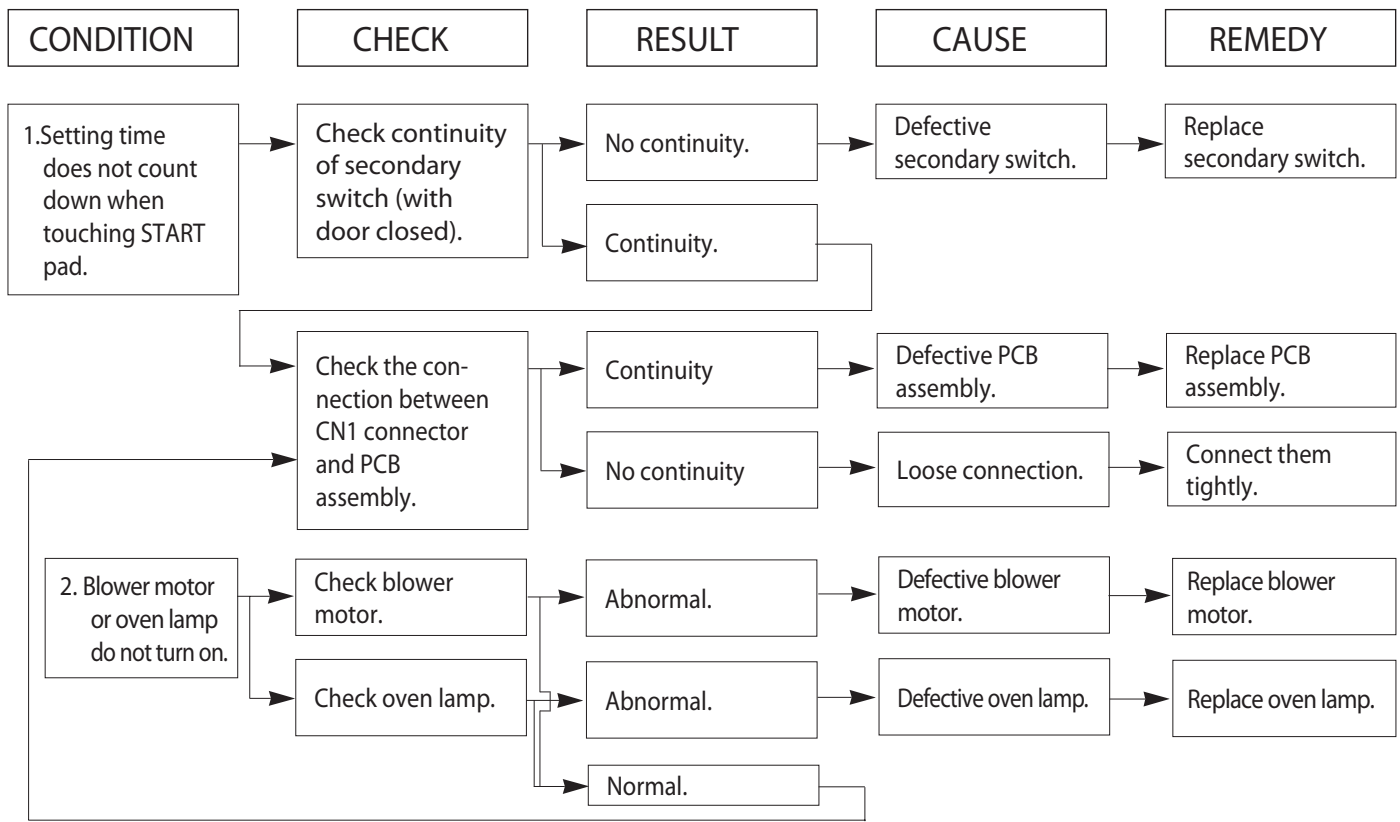

**Trouble 4:** Oven seems to be operating but little heat is produced in oven load.

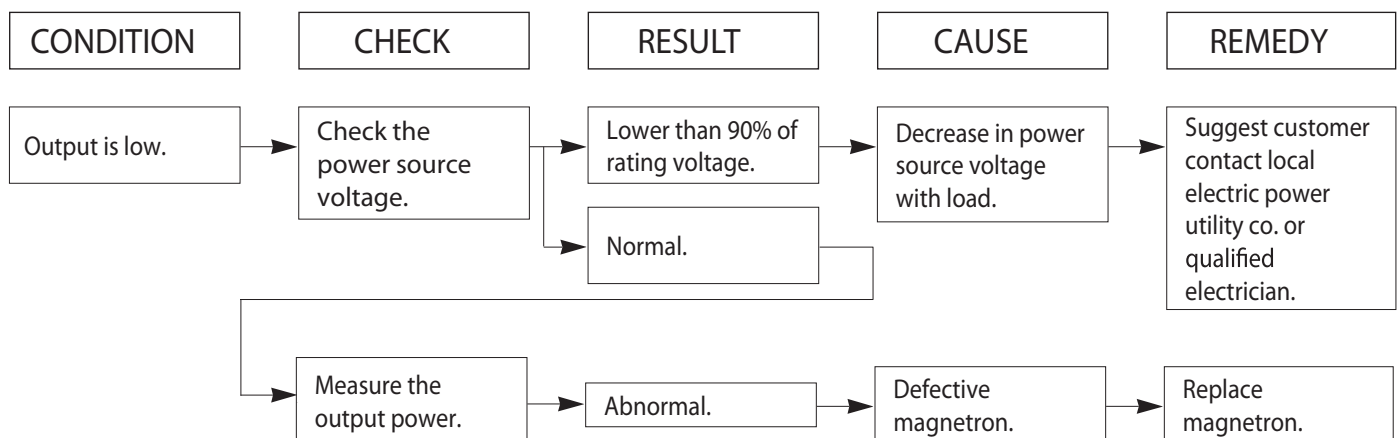

# Troubleshooting

## TROUBLE 5: No microwave oscillation even though oven lamp and blower motor run.

(Display operates properly)

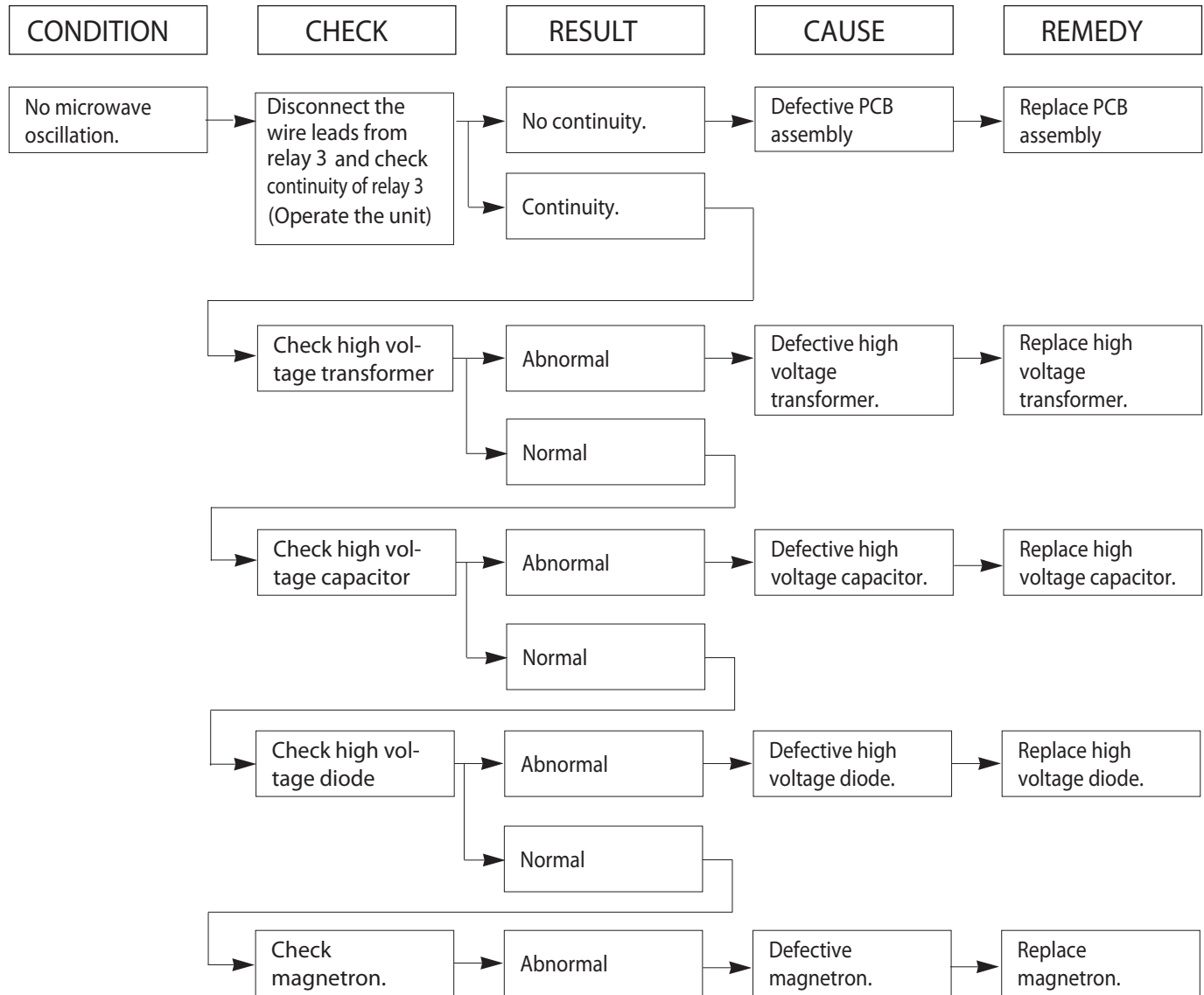

NOTE : • Make sure the wire leads are in the correct position.

- When Removing the wire leads from the parts, be sure to grasp the connector, not the wires.
- When removing the magnetron, be sure to install the magnetron gasket in the correct position and in good condition.

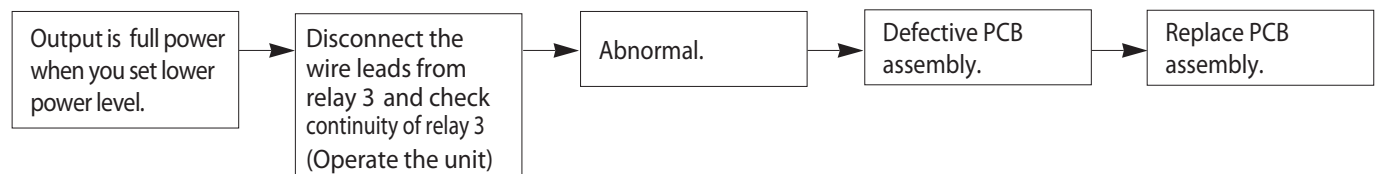

# 9 | Schematic / Wiring Diagrams

# Schematic / Wiring Diagram RFS12MPSB, RFS12SW2B

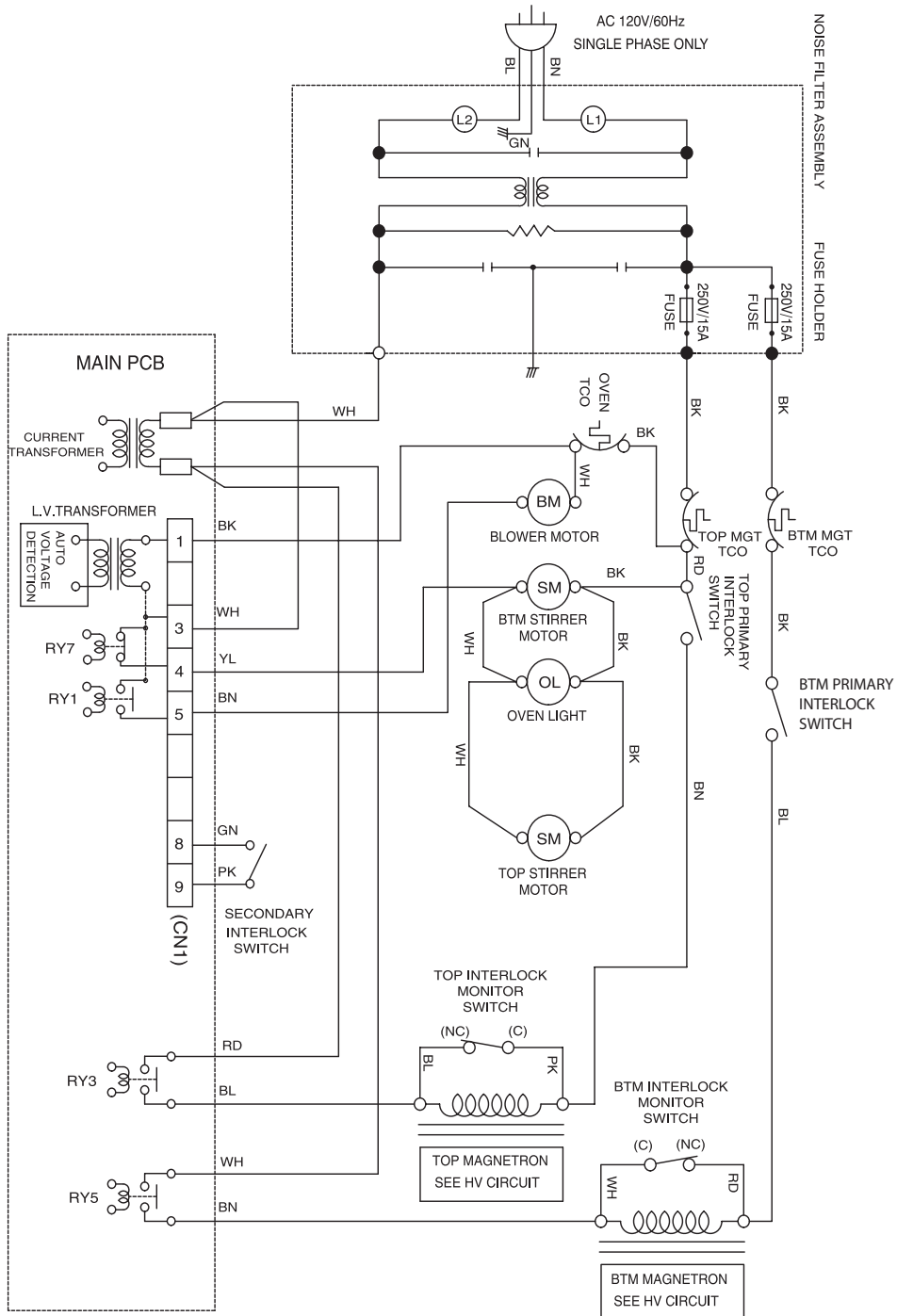

NOTE:  
1. DOOR IS OPENED.  
2. WIRE COLOR

SYMBOL	COLOR
BK	BLACK
BN	BROWN
BL	BLUE
GN	GREEN
PK	PINK
RD	RED
WH	WHITE
YL	YELLOW

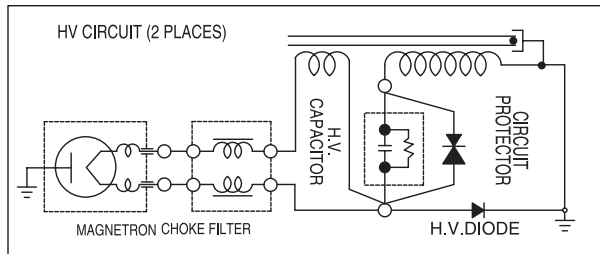

**! DANGER**  
HIGH VOLTAGE

# Schematic / Wiring Diagram RFS12SW2C

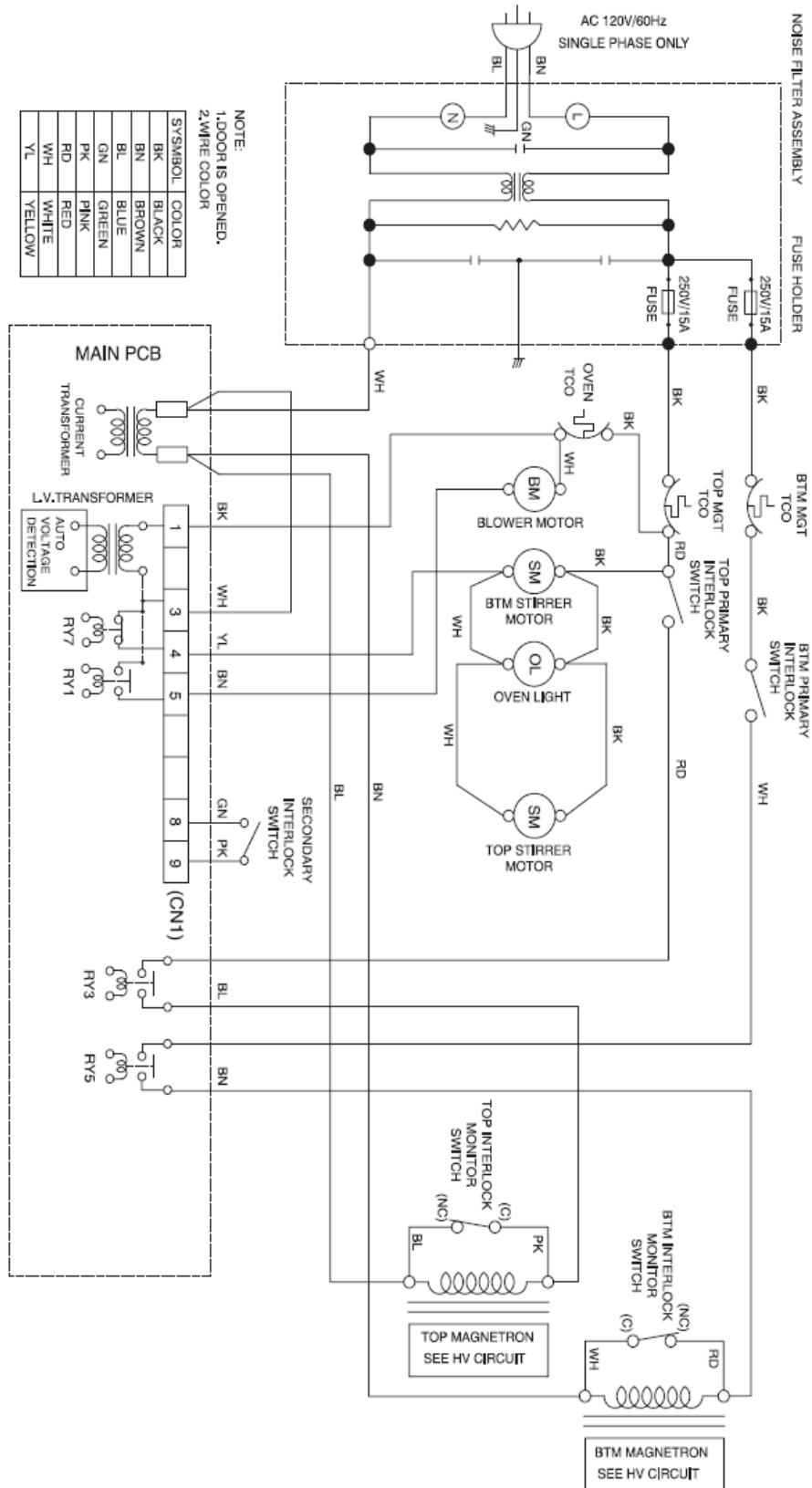

NOTE:  
1. DOOR IS OPENED.  
2. WIRE COLOR

SYMBOL	COLOR
BK	BLACK
BN	BROWN
BL	BLUE
GN	GREEN
PK	PINK
RD	RED
WH	WHITE
YL	YELLOW

**DANGER**  
HIGH VOLTAGE

# Schematic / Wiring Diagram RFS12TS(W)

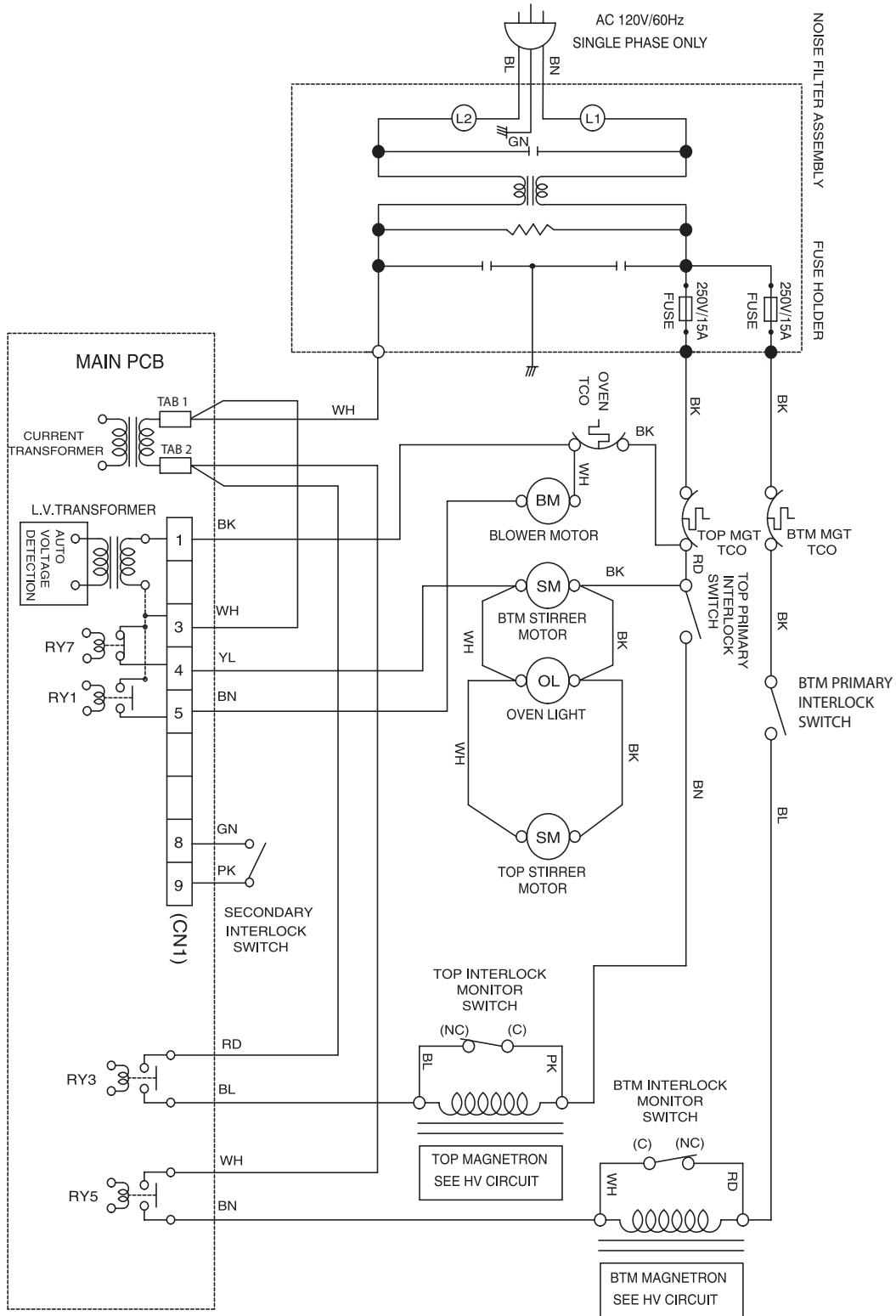

NOTE:  
 1. DOOR IS OPENED.  
 2. WIRE COLOR

SYMBOL	COLOR
BK	BLACK
BN	BROWN
BL	BLUE
GN	GREEN
PK	PINK
RD	RED
WH	WHITE
YL	YELLOW

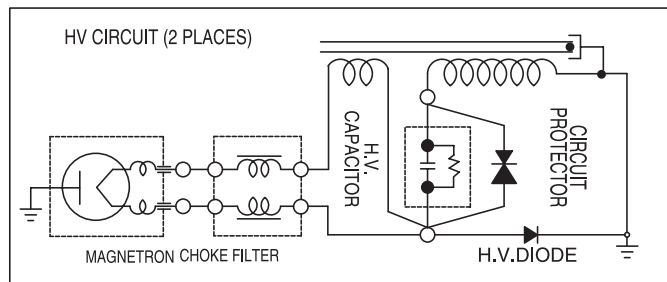

# Schematic / Wiring Diagram RFS18MPS

## WARNING

To avoid risk of electrical shock, personal injury or death, disconnect power to oven and discharge capacitor before servicing, unless testing requires it.

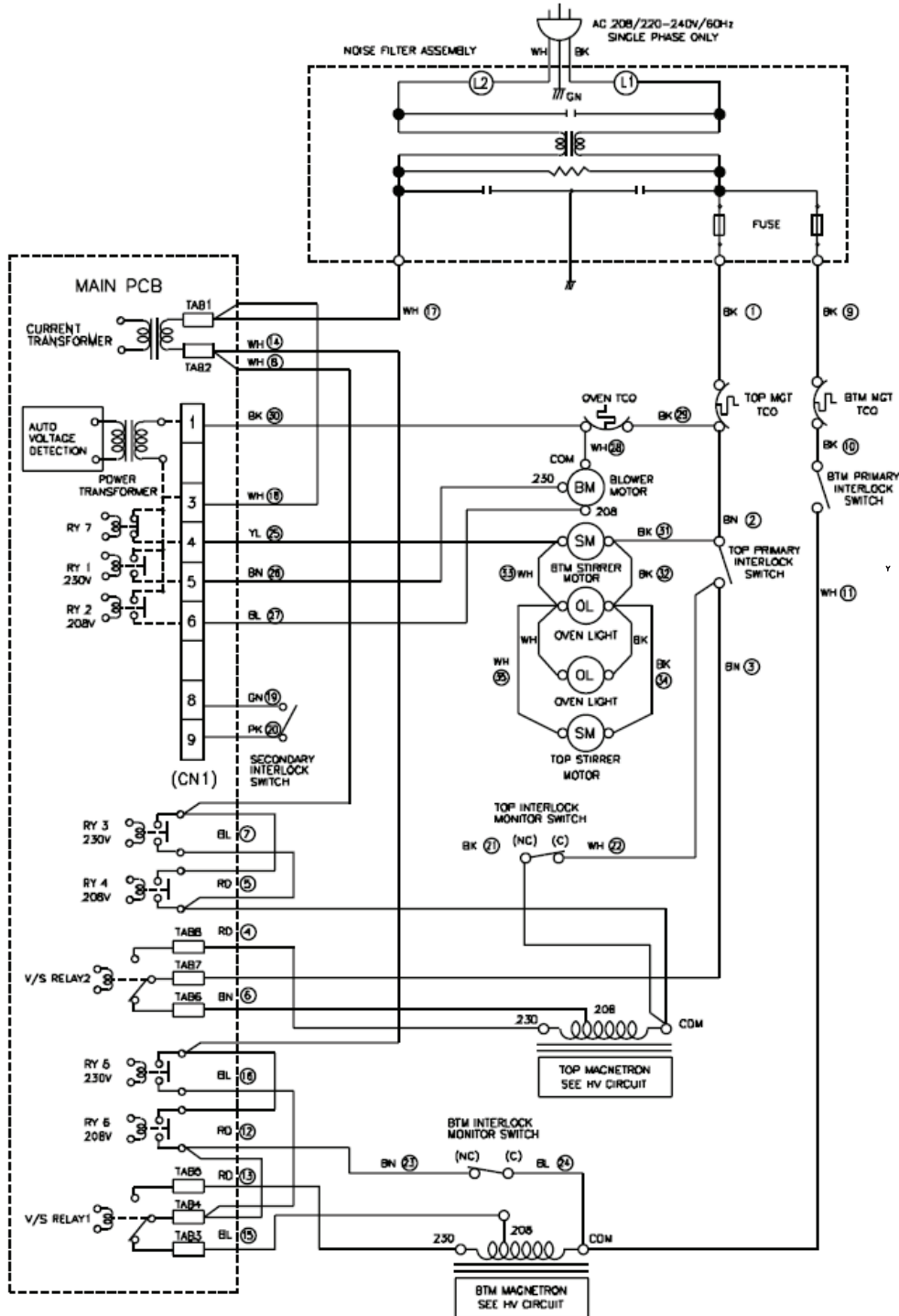

IMPORTANT SAFETY NOTE: THE SHADED AREAS ON THIS SCHEMATIC DIAGRAM INCORPORATE SPECIAL FEATURES IMPORTANT FOR PROTECTION FROM MICROWAVE RADIATION, FIRE, ELECTRICAL SHOCK AND HAZARDS WHEN SERVICING IT IS ESSENTIAL THAT ONLY MANUFACTURER'S SPECIFIED PARTS BE USED FOR THE CRITICAL COMPONENTS IN THE SHADED AREAS OF THE SCHEMATIC DIAGRAM.

NOTICE: SINCE THIS IS BASIC SCHEMATIC DIAGRAM, THE VALUES OF COMPONENTS AND SOME PARTIAL CONNECTIONS ARE SUBJECT TO CHANGE FOR IMPROVEMENT.

NOTE:  
 1. DOOR IS OPENED.  
 2. WIRE COLOR.

SYMBOL	COLOR
BN	BROWN
WH	WHITE
BK	BLACK
BL	BLUE
YL	YELLOW
PK	PINK
RD	RED
GN	GREEN

### HV CIRCUIT (2 PLACES)

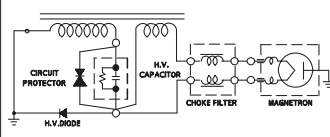

## DANGER

# Schematic / Wiring Diagram RFS18TS



**WARNING**

To avoid risk of electrical shock, personal injury or death, disconnect power to oven and discharge capacitor before servicing, unless testing requires it.

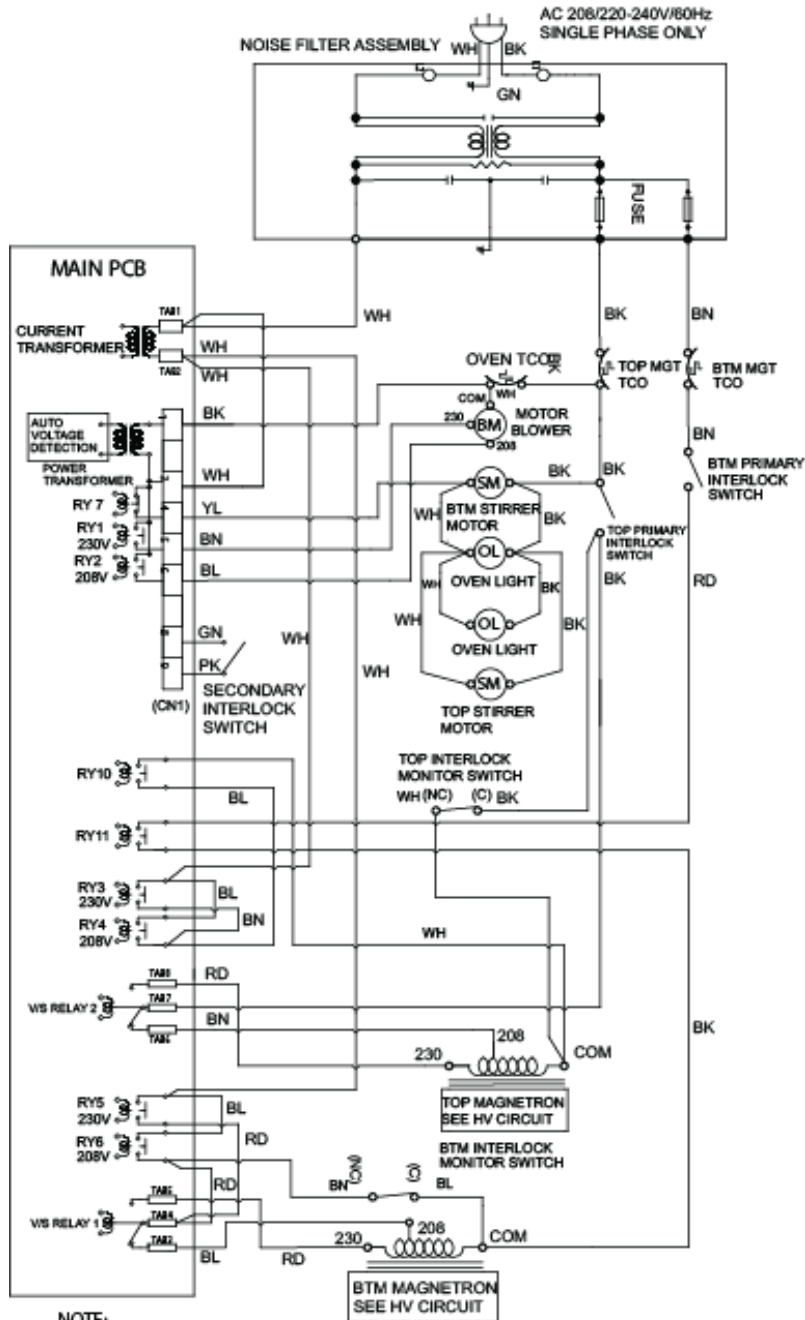

NOTE:  
1. DOOR IS OPENED.  
2. WIRE COLOR

SYMBOL	COLOR
BN	BROWN
WH	WHITE
BK	BLACK
BL	BLUE
YL	YELLOW
PK	PINK
RD	RED
GN	GREEN

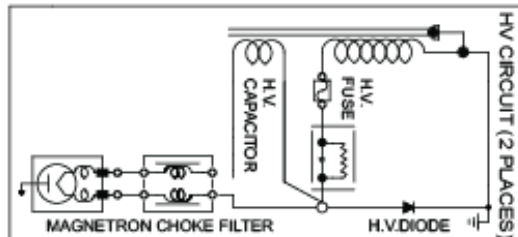

**DANGER**

HIGH VOLTAGE

