

International Commercial Microwave—Technical Information

230/240 V, 50 Hz Models

DECS11MA	P1330217M	DES11EA	P1330218M
DFS11EA	P1330220M	RCS511A	P1330214M
RS511MB	P1330211M	RS511P	P1330212M
RFS511SW2A	P1330223M	UCS11MA	P1330228M
UFS11EA	P1330230M	URCS511A	P1330226M
URS511MB	P1330224M	URS511P	P1330225M
US11EA	P1330229M		

- Due to possibility of personal injury or property damage, always contact an authorized technician for servicing or repair of this unit.
- Refer to Service Manual 16025963 for installation, operating, testing, troubleshooting, and disassembly instruction.



CAUTION

All safety information must be followed as provided in Service Manual 16025963.



WARNING





To avoid the risk of electrical shock, personal injury or death, disconnect power to oven and discharge capacitor before servicing, unless testing requires it.

Models	DECS11MA, DES11EA, DFS11EA, RCS511A, RS511MB, RS511P	RFS511SW2A, UCS11MA, UFS11EA, URCS511A, URS511MB, URS511P, US11EA
Power Source		
Voltage AC	230 VAC	240 VAC
Amperage (Single Unit)	15 A	20 A
Frequency	50 Hz	50 Hz
Single Phase, 3 wire grounded	X	X
Receptacle	5-15R	5-20R
Plug	5-15P	5-20P
Power Output		
Nominal microwave energy (IEC705)	1100 Watts	1100 Watts
Minimum temperature rise (ΔT)	11°F / 5.5°C	11°F / 5.5°C
Operating Frequency	2450 MHz	2450 MHz
Power Consumption		
Cook Condition Microwave	1600 Watts / 13.2 Amps	1700 Watts / 15.8 Amps
Dimensions		
Cabinet		
Width	21 3/4" 55 cm	21 3/4" 55 cm
Height	14 1/4" 36.2 cm	14 1/4" 36.2 cm
Depth	17 7/8" 45.4 cm	17 7/8" 45.4 cm
Oven Interior		
Width	14 1/4" 36.2 cm	14 1/4" 36.2 cm
Height	8 7/8" 22.5 cm	8 7/8" 22.5 cm
Depth	16 3/8" 41.6 cm	16 3/8" 41.6 cm
Weight		
Crated	58 lbs. 26.3 kg	58 lbs. 26.3 kg
Uncrated	51 lbs. 23.1 kg	51 lbs. 23.1 kg

Component Testing Procedures

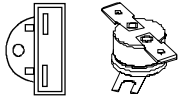
⚠ WARNING

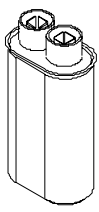
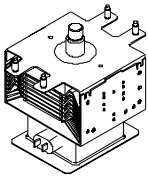
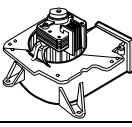
To avoid risk of electrical shock, personal injury or death, disconnect power to oven and discharge capacitor before servicing, unless testing requires it.

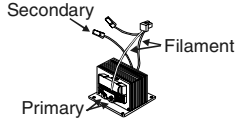
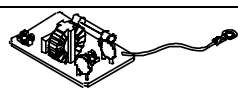
Illustration	Component	Testing	Results
	Thermal cutout	Disconnect all wires from TCO. Measure resistance across terminals. Cavity TCO..... Magnetron TCO.....	Closed at 32°F (0°C) and Opens at 230°F (110°C) Closed at 140°F (60°C) and Opens at 320°F (160°C)
	Diode	Discharge Capacitor Remove diode lead from capacitor and connect ohmmeter. Reverse leads for second test.	Infinite resistance should be measured in one direction and 50KΩ or more in the opposite direction. NOTE: Ohmmeter must contain a battery of 6 volts minimum.
	Circuit Protector	Discharge Capacitor Remove circuit protector leads from capacitor and connect ohmmeter. Reverse leads for second test.	Infinite resistance should be measured in one direction and 50KΩ or more in the opposite direction. NOTE: Ohmmeter must contain a battery of 6 volts minimum.
	Capacitor	Discharge Capacitor Remove wires from capacitor terminals and connect ohmmeter, set on highest resistance scale to terminals. Also check between each terminal and capacitor case.	Between Terminals: Meter should momentarily deflect towards zero then return to over 5 MΩ. If no deflection occurs, or if continuous deflection occurs, replace capacitor. Terminal to Case: Infinite resistance
	Magnetron	Discharge Capacitor Remove wires from magnetron and connect ohmmeter to terminals. Also check between each terminal and ground.	Between Terminals: Less than 1 Ω Each terminal to ground measures Infinite resistance. Note: This test is not conclusive. If oven does not heat and all other components test good replace the magnetron and retest.
	Blower motor	Remove all wires from motor. Measure resistance across coil	Approximately 72 – 82 Ω
	Stirrer motor	Remove all wires from motor. Measure resistance across terminals	Approximately 12.8 – 13.5 KΩ
	Transformer	Discharge Capacitor Remove all wires from terminals. Measure resistance from: Primary Filament Secondary to Ground screw on transformer stack	Less than <3 Ω Less than <1 Ω Approximately 110 – 125 Ω
	Noise filter board	Power In terminals..... Power Out terminals.....	230 / 240 VAC 230 / 240 VAC If no power in, check power outlet. If no power out, check fuses.

Component Testing Procedures

⚠ WARNING

To avoid risk of electrical shock, personal injury or death, disconnect power to oven and discharge capacitor before servicing, unless testing requires it.

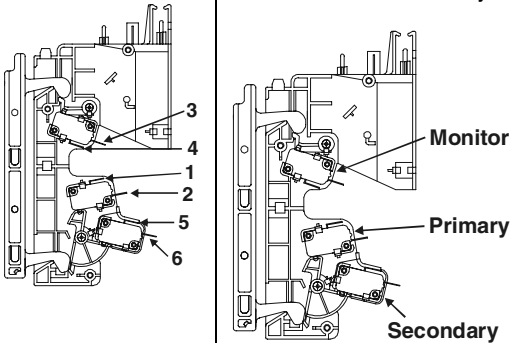
Illustration	Component	Testing	Results
	Interlock switch assembly	<p>Disconnect wires to switch.</p> <p>With door open measure resistance from: Monitor - Terminal 3 - 4..... Primary - Terminal 1 - 2..... Secondary - Terminal 5 - 6.....</p> <p>With door closed measure resistance from: Monitor - Terminal 3 - 4..... Primary - Terminal 1 - 2..... Secondary - Terminal 5 - 6.....</p> <p>After verifying or replacing the module, reconnect wires to switch and check operation of monitor circuit before operating the oven.</p>	<p>Indicates continuity Infinite Ω Infinite Ω</p> <p>Infinite Ω Indicates continuity Indicates continuity</p>
	Lamp receptacle	Test continuity of receptacle terminals.	Indicates continuity with bulb installed.
	Wire Harness	Test continuity of wires	Indicates continuity

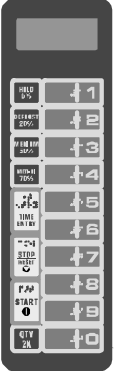
Electronic Control Panel			
	Service Test Mode:	<p>Open door, Press and Hold pad 3 for 5 seconds to enter service test mode.</p> <p>Press Pad 1</p> <p>Press Pad 2</p> <p>Press Pad 3</p> <p>Press Pad 4</p> <p>Press Pad 5</p> <p>Press Pad 6</p> <p>Press Pad 7</p> <p>Press Pad 8</p> <p>Press Pad 9</p> <p>Press Pad 0</p> <p>Stop/Reset Pad</p>	<p>SERVICE appears in the display</p> <p>Indicates number of hours magnetron has been turned on</p> <p>Indicates number of times magnetron tube has cycled</p> <p>Indicates number of door cycles CLEAR (Press START pad to reset service data.)</p> <p>Indicates amperage N/A N/A N/A N/A N/A Exit Service Test Mode</p>
	Error codes:	<p>E-08</p> <p>E-09</p> <p>E-10</p>	<p>Replace Control Board</p> <p>Replace Control Board</p> <p>Shorted or Open Keypad – Test and replace if necessary</p>

Electronic Dial Control Panel			
	Service Test Mode:	<p>Open door, Press and Hold Hidden Pad 2 for 5 seconds to enter service test mode.</p> <p>Press Hidden Pad 2</p> <p>Press Hidden Pad 2 again</p> <p>Press Hidden Pad 2 again</p> <p>Press Hidden Pad 2 again</p> <p>Press Hidden Pad 2 again</p> <p>Press Hidden Pad 2 again</p>	<p>Enters into Service Test Mode</p> <p>Indicates number of magnetron hours</p> <p>Indicates magnetron tube cycles</p> <p>Indicates number of door cycles</p> <p>Indicates amperage</p> <p>Turn dial to Clear Info – When dial is rotated display indicates CLEARED INFO</p>

Component Testing Procedures



WARNING

To avoid risk of electrical shock, personal injury or death, disconnect power to oven and discharge capacitor before servicing, unless testing requires it.

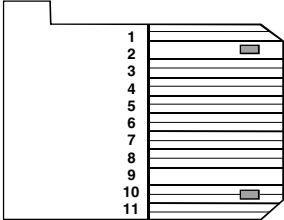
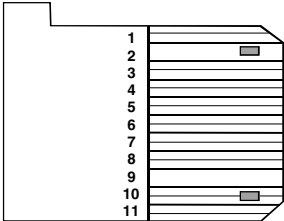
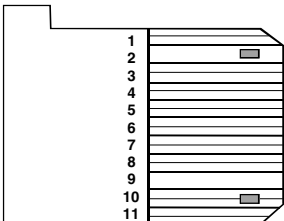
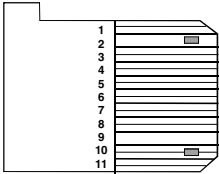
Illustration	Component	Testing	Results		
Electronic Control RS511P URS511P	Keyboard assembly 	Continuity is indicated as 100 Ω and below.	Pad 0 1 2 3 4 5 6 7 8 9 HOLD (0%) DEFROST (20%) MEDIUM (50%) MED-HI (70%) TIME ENTRY STOP/RESET START	Trace 1 & 8 2 & 8 3 & 8 4 & 8 5 & 8 6 & 8 7 & 8 1 & 9 2 & 9 3 & 8 1 & 10 2 & 10 3 & 10 4 & 10 5 & 10 6 & 10 7 & 10	Measurement Continuity Continuity Continuity Continuity Continuity Continuity Continuity Continuity Continuity Continuity Continuity Continuity Continuity Continuity Continuity Continuity Continuity Continuity
Electronic Control DFS11EA RCS511A UFS11EA URCS511A	Keyboard assembly 	Continuity is indicated as 100 Ω and below.	Pad 0 1 2 3 4 5 6 7 8 9 QTY 2X HOLD (0%) DEFROST (20%) MEDIUM (50%) MED-HI (70%) TIME ENTRY STOP/RESET START	Trace 1 & 8 2 & 8 3 & 8 4 & 8 5 & 8 6 & 8 7 & 8 1 & 9 2 & 9 3 & 8 7 & 9 1 & 10 2 & 10 3 & 10 4 & 10 5 & 10 6 & 10 7 & 10	Measurement Continuity Continuity Continuity Continuity Continuity Continuity Continuity Continuity Continuity Continuity Continuity Continuity Continuity Continuity Continuity Continuity Continuity Continuity
Electronic Control DES11EA US11EA	Keyboard assembly 	Continuity is indicated as 100 Ω and below.	Pad 0 1 2 3 4 5 6 7 8 9 TIME ENTRY STOP/RESET START	Trace 1 & 8 2 & 8 3 & 8 4 & 8 5 & 8 6 & 8 7 & 8 1 & 9 2 & 9 3 & 8 5 & 10 6 & 10 7 & 10	Measurement Continuity Continuity Continuity Continuity Continuity Continuity Continuity Continuity Continuity Continuity Continuity Continuity Continuity
Dial Control DECS11MA RCS511MB UCS11MA URS511MB	Keyboard assembly 	Continuity is indicated as 100 Ω and below.	Pad 30 QUICK SET HIDDEN #1 HIDDEN #2 DEFROST (20%) MEDIUM (50%) MED-HI (70%) TIME ENTRY STOP/RESET START	Trace 1 & 8 2 & 8 3 & 8 2 & 10 3 & 10 4 & 10 5 & 10 6 & 10 7 & 10	Measurement Continuity Continuity Continuity Continuity Continuity Continuity Continuity Continuity Continuity Continuity

Component Testing Procedures

⚠ WARNING

To avoid risk of electrical shock, personal injury or death, disconnect power to oven and discharge capacitor before servicing, unless testing requires it.

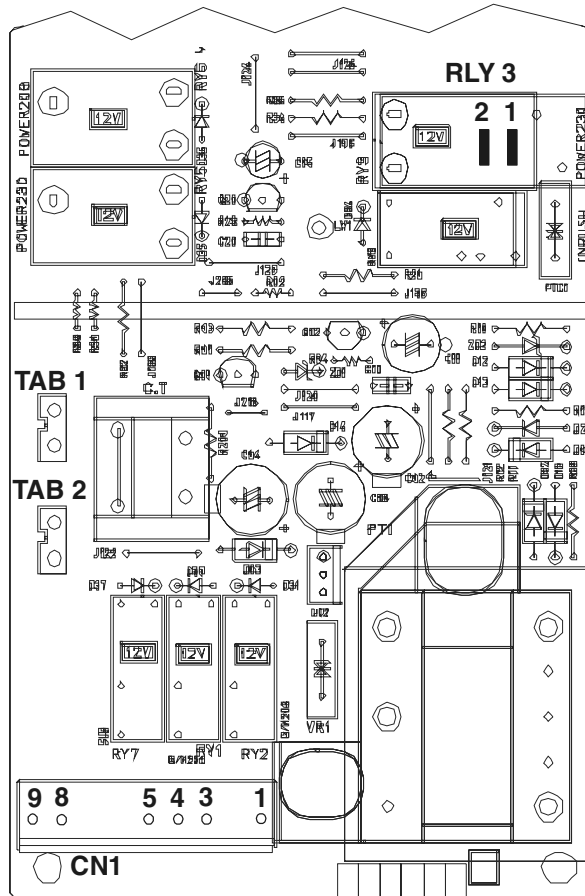

Function	Test Set-Up / Condition	Meter Setting	Probe Placement	Results
Power to current transformer	All Conditions	Volts	Tab 1 to Neutral on Noise Filter Board.....	230/240 VAC
Power from current transformer	All Conditions	Volts	Tab 2 to Neutral on Noise Filter Board.....	230/240 VAC
Power from Oven TCO	All Conditions	Volts	CN1 – Pin 1 (Black wire to Neutral).....	230/240 VAC
Power to Oven Light	Standby.....	Volts	CN1 – Pin 4 to N on Noise Filter Board.....	230/240 VAC
	Ready.....	Volts	CN1 – Pin 4 to N on Noise Filter Board.....	0 VAC
	Cook.....	Volts	CN1 – Pin 4 to N on Noise Filter Board.....	0 VAC
Power to Blower Motor	Standby.....	Volts	CN1 – Pin 5 to N on Noise Filter Board.....	230/240 VAC
	Ready.....	Volts	CN1 – Pin 5 to N on Noise Filter Board.....	0 VAC
	Cook.....	Volts	CN1 – Pin 5 to N on Noise Filter Board.....	0 VAC
Secondary Interlock Switch	Door Closed...	Ohms	CN1 – Pin 8 to Pin 9.....	Continuity
	Door Opened..	Ohms	CN1 – Pin 8 to Pin 9.....	Infinite
Power to Relay 3 (RLY 3)	Standby.....	Volts	Relay 3 – Pin 1 to N on Noise Filter Board....	230/240 VAC
	Ready w/door closed.....	Volts	Relay 3 – Pin 1 to N on Noise Filter Board....	230/240 VAC
	Cook.....	Volts	Relay 3 – Pin 1 to N on Noise Filter Board....	0 VAC

Component Testing Procedures



WARNING

To avoid risk of electrical shock, personal injury or death, disconnect power to oven and discharge capacitor before servicing, unless testing requires it.

All Amana and Menumaster microwave oven power outputs are rated using the IEC705 standards. Using the IEC705 test method requires precision measurements and equipment that is not practical to be performed in the field. Using the test shown below will indicate if the oven performance is satisfactory.

Test equipment required:

- 1000 ml test container and thermometer (Amana power test kit R0157397 Fahrenheit / Menumaster power test kit M95D5 Celsius).
- Digital watch / watch with a second hand for use on ovens with electromechanical timers.

Important Notes:

- Low line voltage will cause low temperature rise / power output.
- Ovens must be on a dedicated circuit, properly grounded, and polarized. Other equipment on the same circuit may cause a low temperature rise / power output.
- This test and results are not a true IEC705 test procedure and are only intended to provide servicers with an easy means of determining if the microwave oven cooking output is correct.

Procedure

1. Fill the test container to the 1000 ml line with cool tap water.

NOTE: Water temperature should be approximately 60°F / 16°C

2. Using the thermometer, stir water for five to ten seconds; measure, and record the temperature (T1).
3. Place test container of water in the center of oven cavity and close door.
4. Heat the water for a 33-second full power cycle.

NOTE: Use a digital watch or a watch with a second hand for ovens with electromechanical timers.

5. At end of the cycle, remove test container. Using the thermometer, stir water for five to ten seconds and record temperature (T2).
6. Subtract the starting water temperature (T1), from the ending water temperature (T2) to obtain the temperature rise (ΔT).
7. If the temperature rise (ΔT) meets or exceeds the minimum, the test is complete. If the temperature rise (ΔT) fails to meet the minimum temperature rise, test the line voltage to verify it is correct. Then repeat steps 1 - 6 making sure to change the water. If the temperature rise (ΔT) fails to meet the minimum temperature rise again the oven will require service.

Minimum Temperature Rise at Thirty -Three (33) Seconds Run Time

ΔT (°F)	Cooking Power Output	ΔT (°F)	Cooking Power Output	ΔT (°C)	Cooking Power Output	ΔT (°C)	Cooking Power Output
10.....	1000	20.....	2000	5	1000	11.....	2000
11.....	1100	21.....	2100	5.5	1100	11.5.....	2100
12.....	1200	22.....	2200	6.5	1200	12.....	2200
14.....	1400	24.....	2400	7.5	1400	13.....	2400
17.....	1700	25.....	2500	9.5	1700	13.5.....	2500
18.....	1800	27.....	2700	10	1800	15.....	2700
19.....	1900	30.....	3000	10.5	1900	16.5.....	3000

Wiring and Schematic Diagram

⚠ WARNING

To avoid risk of electrical shock, personal injury or death, disconnect power to oven and discharge capacitor before servicing, unless testing requires it.

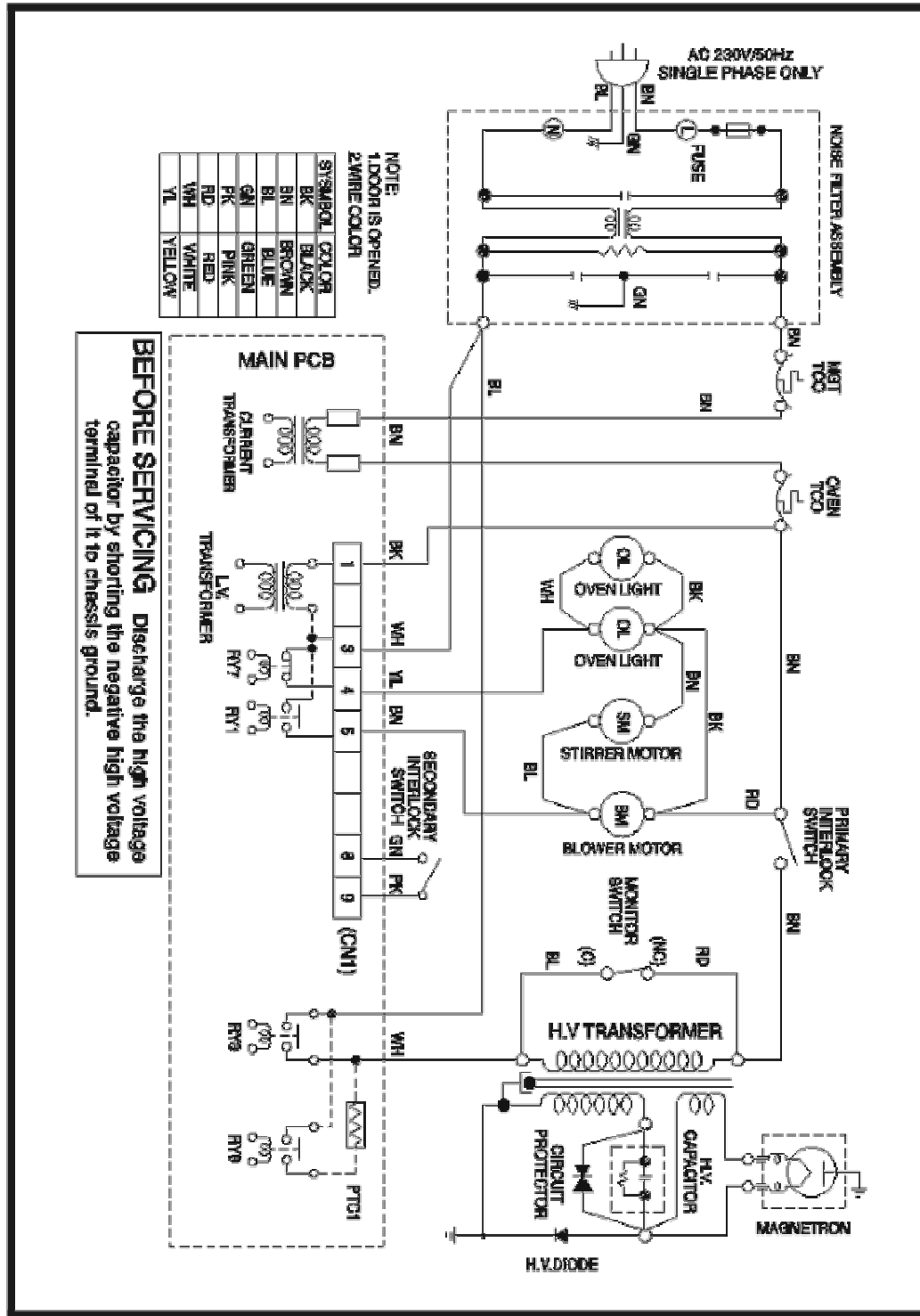

⚠ DANGER

HIGH VOLTAGE