

International Commercial Microwave—Technical Information

230/240 V, 50 Hz Models

DFS18E

P1330222M

RFS518S

P1330216M

UFS518E

P1330231M

URFS518S

P1330227M

- Due to possibility of personal injury or property damage, always contact an authorized technician for servicing or repair of this unit.
- Refer to Service Manual 16026086 for installation, operating, testing, troubleshooting, and disassembly instruction.



CAUTION

All safety information must be followed as provided in Service Manual 16026086.



WARNING





To avoid the risk of electrical shock, personal injury or death, disconnect power to oven and discharge capacitor before servicing, unless testing requires it.

Models	DFS18E, RFS518S	UFS18E, URFS518S
Power Source		
Voltage AC	230 VAC	240 VAC
Amperage (Single Unit)	12 A	12 A
Frequency	50 Hz	50 Hz
Single Phase, 3 wire grounded	X	X
Plug	CEE 7/7 Schuko; 16 A	BS 1363A; 13 A
Power Output		
Nominal microwave energy (IEC705)	1800 Watts	1800 Watts
Minimum temperature rise (ΔT)	18°F / 10°C	18°F / 10°C
Operating Frequency	2450 MHz	2450 MHz
Power Consumption		
Cook Condition Microwave	1,900 Watts / 8.3 Amps	1,900 Watts / 8.3 Amps
Dimensions		
Cabinet		
Width	21 3/4" 55 cm	21 3/4" 55 cm
Height	14 1/4" 36.2 cm	14 1/4" 36.2 cm
Depth	20" 50.8 cm	20" 50.8 cm
Oven Interior		
Width	13 1/2" 34.3 cm	13 1/2" 34.3 cm
Height	9 1/2" 24.1 cm	9 1/2" 24.1 cm
Depth	15 3/4" 40 cm	15 3/4" 40 cm
Weight		
Crated	61 lbs. 28 kg	61 lbs. 28 kg
Uncrated	55 lbs. 25 kg	55 lbs. 25 kg

Component Testing Procedures

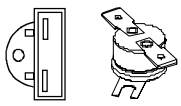
⚠ WARNING

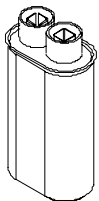
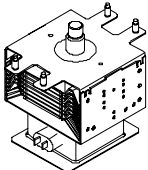
To avoid risk of electrical shock, personal injury or death, disconnect power to oven and discharge capacitor before servicing, unless testing requires it.

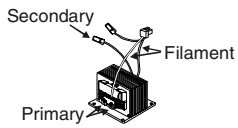
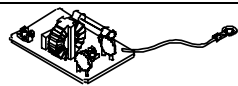
Illustration	Component	Testing	Results
	Thermal cutout	Disconnect all wires from TCO. Measure resistance across terminals. Cavity TCO..... Magnetron TCO.....	Closed at 32°F (0°C) and Opens at 230°F (110°C) Closed at 140°F (60°C) and Opens at 320°F (160°C)
	Diode	Discharge Capacitor Remove diode lead from capacitor and connect ohmmeter. Reverse leads for second test.	Infinite resistance should be measured in one direction and 50KΩ or more in the opposite direction. NOTE: Ohmmeter must contain a battery of 6 volts minimum.
	Circuit Protector	Discharge Capacitor Remove diode lead from capacitor and connect ohmmeter. Reverse leads for second test.	Infinite resistance should be measured in one direction and 50KΩ or more in the opposite direction. NOTE: Ohmmeter must contain a battery of 6 volts minimum.
	Capacitor	Discharge Capacitor Remove wires from capacitor terminals and connect ohmmeter, set on highest resistance scale to terminals. Also check between each terminal and capacitor case.	Between Terminals: Meter should momentarily deflect towards zero then return to over 5 MΩ. If no deflection occurs, or if continuous deflection occurs, replace capacitor. Terminal to Case: Infinite resistance
	Magnetron	Discharge Capacitor Remove wires from magnetron and connect ohmmeter to terminals. Also check between each terminal and ground.	Between Terminals: Less than 1 Ω Each terminal to ground measures Infinite resistance. Note: This test is not conclusive. If oven does not heat and all other components test good replace the magnetron and retest.
	Blower motor	Remove all wires from motor. Measure resistance across coil	Approximately 40 – 44 Ω
	Stirrer motor	Remove all wires from motor. Measure resistance across terminals	Approximately 12.8 – 13.5 KΩ
	Transformer	Discharge Capacitor Remove all wires from terminals. Measure resistance from: Primary Filament..... Secondary to Ground screw on transformer stack.....	Less than <1 Ω Less than <1 Ω Approximately 121 – 128 Ω
	Noise filter board	Power In terminals..... Power Out terminals.....	230/240 VAC 230/240 VAC If no power in, check power outlet. If no power out, check fuses.
	Lamp receptacle	Test continuity of receptacle terminals.	Indicates continuity with bulb installed.
	Wire Harness	Test continuity of wires	Indicates continuity

Component Testing Procedures

⚠ WARNING

To avoid risk of electrical shock, personal injury or death, disconnect power to oven and discharge capacitor before servicing, unless testing requires it.

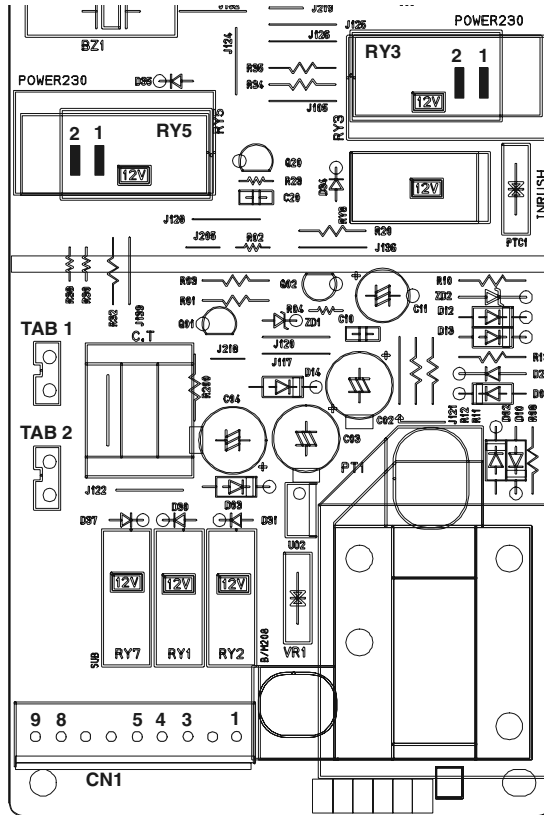

Function	Test Set-Up / Condition	Meter Setting	Probe Placement	Results
Control power transformer input	All Conditions	Volts	CN1 – Pin 3 to Pin 1 (White to Black)	230/240 VAC
Current transformer input	All Conditions	Volts	Tab 1 to Power Cord Blue (Neutral)	230/240VAC
Current transformer output	All Conditions	Volts	Tab 2 to Power Cord Blue (Neutral)	230/240VAC
Oven light relay RY7	Standby..... Ready..... Cook.....	Volts Volts Volts	CN1 – Pin 4 to Pin 1 (Yellow to Black).. CN1 – Pin 4 to Pin 1..... CN1 – Pin 4 to Pin 1.....	0 VAC 230/240VAC 230/240VAC
Blower / Stirrer motor relay RY1	Standby..... Ready..... Cook.....	Volts Volts Volts	CN1 – Pin 5 to Pin 3 (Brown to White).. CN1 – Pin 5 to Pin 3..... CN1 – Pin 5 to Pin 3.....	230/240VAC 0 VAC 0 VAC
Secondary Interlock Switch	Door Closed..... Door Opened....	Ohms Ohms	CN1 – Pin 8 to Pin 9 (Pink to Green) CN1 – Pin 8 to Pin 9.....	< 1 Ω Infinite
Cook relay RY3	Standby..... Ready..... Cook.....	Volts Volts Volts	Relay 3 – Pin 1 to Pin 2..... Relay 3 – Pin 1 to Pin 2..... Relay 3 – Pin 1 to Pin 2.....	230/240VAC 230/240VAC 0 VAC
Cook relay RY5	Standby..... Ready..... Cook.....	Volts Volts Volts	Relay 5 – Pin 1 to Pin 2..... Relay 5 – Pin 1 to Pin 2..... Relay 5 – Pin 1 to Pin 2.....	230/240VAC 230/240VAC 0 VAC

Component Testing Procedures



WARNING

To avoid risk of electrical shock, personal injury or death, disconnect power to oven and discharge capacitor before servicing, unless testing requires it.

All Amana and Menumaster microwave oven power outputs are rated using the IEC705 standards. Using the IEC705 test method requires precision measurements and equipment that is not practical to be performed in the field. Using the test shown below will indicate if the oven performance is satisfactory.

Test equipment required:

- 1000 ml test container and thermometer (Amana power test kit R0157397 Fahrenheit / Menumaster power test kit M95D5 Celsius).
- Digital watch / watch with a second hand for use on ovens with electromechanical timers.

Important Notes:

- Low line voltage will cause low temperature rise / power output.
- Ovens must be on a dedicated circuit, properly grounded, and polarized. Other equipment on the same circuit may cause a low temperature rise / power output.
- This test and results are not a true IEC705 test procedure and are only intended to provide servicers with an easy means of determining if the microwave oven cooking output is correct.

Procedure

1. Fill the test container to the 1000 ml line with cool tap water.

NOTE: Water temperature should be approximately 60°F / 16°C

2. Using the thermometer, stir water for five to ten seconds; measure, and record the temperature (T1).
3. Place test container of water in the center of oven cavity and close door.
4. Heat the water for a 33-second full power cycle.

NOTE: Use a digital watch or a watch with a second hand for ovens with electromechanical timers.

5. At end of the cycle, remove test container. Using the thermometer, stir water for five to ten seconds and record temperature (T2).
6. Subtract the starting water temperature (T1), from the ending water temperature (T2) to obtain the temperature rise (ΔT).
7. If the temperature rise (ΔT) meets or exceeds the minimum, the test is complete. If the temperature rise (ΔT) fails to meet the minimum temperature rise, test the line voltage to verify it is correct. Then repeat steps 1 - 6 making sure to change the water. If the temperature rise (ΔT) fails to meet the minimum temperature rise again the oven will require service.

Minimum Temperature Rise at Thirty -Three (33) Seconds Run Time

ΔT (°F)	Cooking Power Output	ΔT (°F)	Cooking Power Output	ΔT (°C)	Cooking Power Output	ΔT (°C)	Cooking Power Output
10	1000	20	2000	5	1000	11	2000
11	1100	21	2100	5.5	1100	11.5	2100
12	1200	22	2200	6.5	1200	12	2200
14	1400	24	2400	7.5	1400	13	2400
17	1700	25	2500	9.5	1700	13.5	2500
18	1800	27	2700	10	1800	15	2700
19	1900	30	3000	10.5	1900	16.5	3000

Wiring and Schematic Diagram



WARNING

To avoid risk of electrical shock, personal injury or death, disconnect power to oven and discharge capacitor before servicing, unless testing requires it.

BEFORE SERVICING Discharge the high voltage capacitor by shorting the negative high voltage terminal of it to chassis ground.

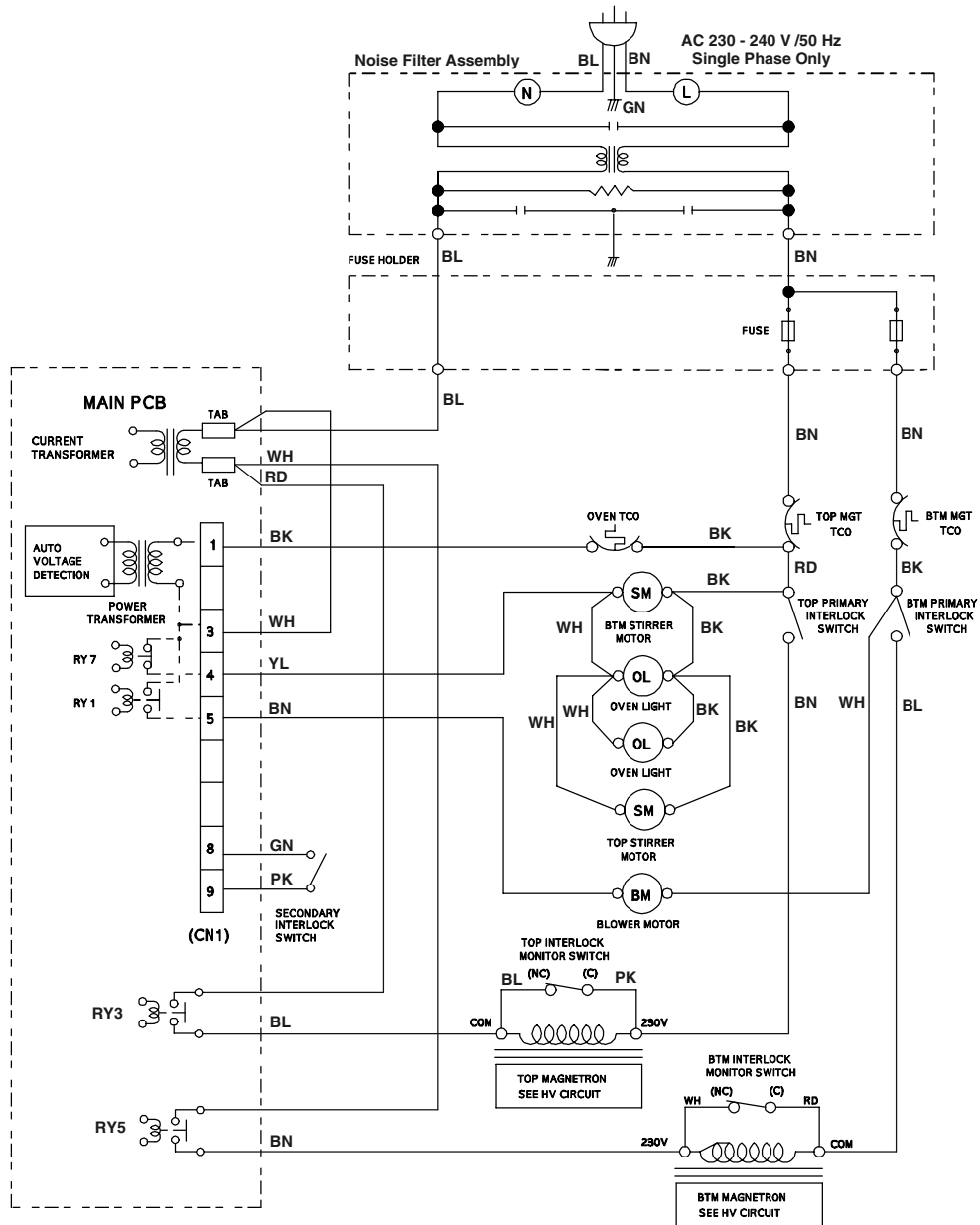

NOTE:
1. DOOR IS OPENED.
2. WIRE COLOR.

SYMBOL	COLOR
BN	BROWN
WH	WHITE
BK	BLACK
BL	BLUE
YL	YELLOW
PK	PINK
RD	RED
GN	GREEN

