Service Manual

Commercial Microwave Oven



RFS12MPSB P1330235M
RFS12SW2B P1330236M
RFS12SW2C P1330237M

60 Hz
July 2010

ACP
INC. *New*
HIGH PERFORMANCE HAS A NAME™
Amana MENUMASTER®

16400007

Important Information

Important Information

Important Notices for Servicers and Consumers

ACP will not be responsible for personal injury or property damage from improper service procedures. Pride and workmanship go into every product to provide our customers with quality products. It is possible, however, that during its lifetime a product may require service. Products should be serviced only by a qualified service technician who is familiar with the safety procedures required in the repair and who is equipped with the proper tools, parts, testing instruments and the appropriate service information. IT IS THE TECHNICIANS RESPONSIBILITY TO REVIEW ALL APPROPRIATE SERVICE INFORMATION BEFORE BEGINNING REPAIRS.



WARNING

To avoid risk of severe personal injury or death, disconnect power before working/servicing on appliance to avoid electrical shock.

To locate an authorized servicer please contact:

ComServ Support Center



Web Site
WWW.ACPSOLUTIONS.COM

Telephone Number
..... 1-866-426-2621 or 319-368-8195

E-Mail: commercialservice@acpsolutions.com

Recognize Safety Symbols, Words, and Labels



DANGER

DANGER— Immediate hazards which WILL result in severe personal injury or death.



WARNING

WARNING— Hazards or unsafe practices which COULD result in severe personal injury or death.



CAUTION

CAUTION— Hazards or unsafe practices which COULD result in minor personal injury, product or property damage.

Table of Contents

Important Information	2	Disassembly Procedures	
Important Safety Information	4	Disconnecting Wire Terminals	21
Grounding Instructions	7	Outer Case	21
General Information		Door Assembly	22
Unpacking Equipment	8	Door Disassembly	22
Equipment Placement	8	Control Removal	23
Radio Interference	8	Interlock Switches	23
Model Identification	8	H.V. Capacitor	24
Service	8	Diode	24
Parts and Accessories	8	Transformer	24
Troubleshooting Procedures	9-13	Fuse / Fuse Block / Filter Assembly	24
Service Information		Magnetron	25
Proper Handling of Magnetron Tubes	14	Blower Motor or Wheel	25
Magnetron Failure Mode	14	Splatter Shield	26
Microwave Leakage Test		Antenna (Upper & Lower)	26
Equipment	15	Stirrer Motor (Upper & Lower)	26
Procedure For Measuring Radiation Leakage	15	Magnetron Thermal Cut-Out (TCO)	27
Measurement With the Outer Panel Removed	15	Cavity Thermal Fuse	27
Measurement With a Fully Assembled Oven	15	Tray Replacement	27
Record Keeping and Notification		Oven Light Removal	27
After Measurement	15		
Testing Procedures	16-19		
Power Test	20		

Important Safety Information



WARNING

Read the following information to avoid possible exposure to microwave radiation:

The basic design of the Microwave Oven makes it an inherently safe device to both use and service.

However, there are some precautions which should be followed when servicing the microwave to maintain this safety. These are as follows:

1. Always operate the unit from an adequately grounded outlet. Do not operate on a two-wire extension cord.
2. Before servicing the unit (if unit is operable) perform the microwave leakage test.
3. The oven should never be operated if the door does not fit properly against the seal, the hinges or hinge bearings are damaged or broken; the choke is damaged, (pieces missing, etc.); or any other visible damage can be noted. Check the choke area to ensure that this area is clean and free of all foreign matter.
4. If the oven operates with the door open and produces microwave energy, take the following steps:
 - A. Tell the user not to operate the oven.
 - B. Contact ACP ComServ immediately.
5. Always have the oven disconnected when the outer case is removed except when making the "live" tests called for in the Service Manual. Do not reach into the equipment area while the unit is energized. Make all connections for the test and check them for tightness before plugging the cord into the outlet.
6. Always ground the capacitors on the magnetron filter box with an insulated-handle screwdriver before working in the high voltage area of the equipment compartment. Some types of failures will leave a charge in these capacitors and the discharge could cause a reflex action which could make you injure yourself.
7. Always remember that in the area of the transformer there is HIGH VOLTAGE. When the unit is operating keep this area clear and free of anything which could possibly cause an arc or ground, etc.
8. Do not for any reason defeat the interlock switches there is not valid reason for this action at any time; nor will it be condoned by ACP.
9. IMPORTANT: Before returning a unit to a customer, be sure to check for proper switch interlock action.
10. The Microwave Oven should never be operated with any components removed and/or bypassed or when any of the safety interlocks are found to be defective, or when any of the seal surfaces are defective, missing, or damaged.
11. All microwave ovens meet all requirements of the radiation control for Health and Safety Act of 1968. Due to measurement uncertainties, the maximum leakage for the field will be $4\text{mw}/\text{cm}^2$.
12. To ensure that the unit does not emit excessive microwave leakage and to meet the Department of Health and Human Services guidelines, check the oven for microwave leakage using a microwave oven leakage meter that complies with US Government CDRH / FDA / DHHS requirements and or any other local government requirements. The maximum leakage level allowed by ACP is $4\text{mw}/\text{cm}^2$.
13. If servicer encounters an emission reading over $4\text{mw}/\text{cm}^2$, the servicer is to cease repair and contact the ACP ComServ Department immediately for further direction. ACP will contact the proper Government Agency upon verification of the test results.

Important Safety Information



Recognize this symbol as a SAFETY message



WARNING

When using electrical equipment, basic safety precautions should be followed to reduce the risk of burns, electrical shock, fire, or injury to persons.

1. READ all instructions before using equipment.
2. READ AND FOLLOW the specific "PRECAUTIONS TO AVOID POSSIBLE EXPOSURE TO EXCESSIVE MICROWAVE ENERGY".
3. This equipment **MUST BE GROUNDED**. Connect only to properly GROUNDED outlet. See "GROUNDING INSTRUCTIONS".
4. Install or locate this equipment **ONLY** in accordance with the installation instructions in this manual.
5. Some products such as whole eggs and sealed containers, for example, closed glass jars may explode and **SHOULD NOT** be HEATED in this oven.
6. Use this equipment **ONLY** for its intended use as described in this manual. Do not use corrosive chemicals or vapors in this equipment. This type of oven is specifically designed to heat or cook. It is not designed for industrial or laboratory use.
7. As with any equipment, **CLOSE SUPERVISION** is necessary when used by **CHILDREN**.
8. **DO NOT** operate this equipment if it has a damaged cord or plug, if it is not working properly, or if it has been damaged or dropped.
9. This equipment, including power cord, must be serviced **ONLY** by qualified service personnel. Special tools are required to service equipment. Contact nearest authorized service facility for examination, repair, or adjustment.
10. **DO NOT** cover or block filter or other openings on equipment.
11. **DO NOT** store this equipment outdoors. **DO NOT** use this product near water, for example, near a kitchen sink, in a wet basement, or near a swimming pool etc.
12. **DO NOT** immerse cord or plug in water.
13. Keep cord **AWAY** from **HEATED** surfaces.
14. **DO NOT** let cord hang over edge of table or counter.
15. See door cleaning instructions in "Care and Cleaning" section.
16. For commercial use only.



CAUTION

To reduce risk of fire in the oven cavity:

- a. **DO NOT** overcook food. Carefully attend equipment if paper, plastic, or other combustible materials are placed inside the oven to facilitate cooking.
- b. Remove wire twist-ties from paper or plastic bags before placing bag in oven.
- c. **KEEP** oven **DOOR CLOSED**, turn oven off, and disconnect the power cord, or shut off power at the fuse or circuit breaker panel, if materials inside the oven should ignite. Fire may spread if door is opened.
- d. **DO NOT** use the cavity for storage. **DO NOT** leave paper products, cooking utensils, or food in oven.

SAVE THESE INSTRUCTIONS

Important Safety Information



CAUTION

To avoid risk of personal injury or property damage, observe the following:

1. Briskly stir or pour liquids before heating with microwave energy to prevent spontaneous boiling or eruption. Do not overheat. If air is not mixed into a liquid, liquid can erupt in oven or after removal from oven.
2. Do not deep fat fry in oven. Fat could overheat and be hazardous to handle.
3. Do not cook or reheat eggs in shell or with an unbroken yolk using microwave energy. Pressure may build up and erupt. Pierce yolk with fork or knife before cooking.
4. Pierce skin of potatoes, tomatoes, and similar foods before cooking with microwave energy. When skin is pierced, steam escapes evenly.
5. Do not operate equipment without load or food in oven cavity.
6. Do not use regular cooking thermometers in oven. Most cooking thermometers contain mercury and may cause an electrical arc, malfunction, or damage to oven.
7. Do not heat baby bottles in oven.
8. Never use paper, plastic, or other combustible materials that are not intended for cooking.
9. When cooking with paper, plastic, or other combustible materials, follow manufacturer's recommendations on product use.
10. Do not heat sealed containers or plastic bags in oven. Food or liquid could expand quickly and cause container or bag to break. Pierce or open container or bag before heating.
11. To avoid pacemaker malfunction, consult physician or pacemaker manufacturer about effects of microwave energy on pacemaker.

PRECAUTIONS TO AVOID POSSIBLE EXPOSURE TO EXCESSIVE MICROWAVE ENERGY

- a. DO NOT attempt to operate this oven with the door open since open-door operation can result in harmful exposure to microwave energy. It is important not to defeat or tamper with the safety interlocks.
- b. DO NOT place any object between the oven front face and the door or allow soil or cleaner residue to accumulate on sealing surfaces.
- c. DO NOT operate the oven if it is damaged. It is particularly important that the oven door close properly and that there is no damage to the: (1) door (bent), (2) hinges and latches (broken or loosened), (3) door seals and sealing surfaces.
- d. The oven should NOT be adjusted or repaired by anyone except properly qualified service personnel.

SAVE THESE INSTRUCTIONS

Important Safety Information

WARNING

PRECAUTIONS TO BE OBSERVED BEFORE AND DURING SERVICING TO AVOID POSSIBLE EXPOSURE TO EXCESSIVE MICROWAVE ENERGY, OR ELECTRICAL SHOCK. DISCONNECT POWER TO OVEN.

- Do not operate or allow oven to be operated with door open.
- Make the following safety checks on all ovens to be serviced before activating the magnetron or other microwave source, and make repairs as necessary:
 - Interlock operation
 - Proper door closing
 - Seal and sealing surfaces (arcing, wear, and other damage)
 - Damage to or loosening of hinges and latches
 - Evidence of dropping or abuse
- Before turning on microwave power for any service test or inspection within the microwave generating compartments, check the magnetron, waveguide or transmission line, and cavity for proper alignment, integrity, and connections.
- Any failed or misadjusted components in the interlock, monitor, door seal, and microwave generation and transmission systems shall be repaired, replaced or adjusted by procedures described in this manual before oven is released to the consumer.
- Check microwave leakage to verify compliance with the federal performance standard should be performed on each oven prior to release to the consumer.

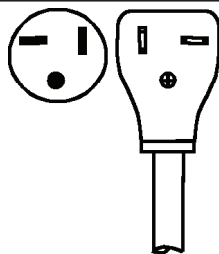

NEMA 5-20R/5-20P
120V-20AMP

Grounding Instructions

WARNING

To avoid risk of electrical shock, injury or death; make sure these grounding instructions are followed.

WARNING

Do not remove grounding prong when installing grounded appliance in a home or business that does not have three wire grounding receptacle, under no condition is grounding prong to be cut off or removed. It is the personal responsibility of the consumer to contact a qualified electrician and have properly grounded three prong wall receptacle installed in accordance with appropriate electrical codes.

WARNING

To avoid the risk of electrical shock or death, do not alter the plug.

WARNING

To avoid the risk of electrical shock or death, this equipment must be grounded.

This equipment **MUST** be grounded. In the event of an electrical short circuit, grounding reduces the risk of electric shock by providing an escape wire for the electric current. This oven is equipped with a cord having a grounding wire with a grounding plug. The plug must be plugged into an outlet that is properly installed and grounded.

Consult a qualified electrician or servicer if grounding instructions are not completely understood, or if doubt exists as to whether the equipment is properly grounded.

Do not use an extension cord. If the product power cord is too short, have a qualified electrician install an appropriate receptacle. This oven should be plugged into a separate 50 or 60 hertz circuit with the electrical rating as shown in the appropriate drawing. Models operate with a 120 supply voltage. When an oven is on a circuit with other equipment, an increase in cooking times may be required and fuses can be blown.

General Information

Model Identification

- For ACP product call 1-866-426-2621 or visit the Web Site at www.acpsolutions.com

When contacting for service support, provide product information located on rating plate. Record the following:

Model Number: _____
Manufacturing Number: _____
Serial or S/N Number: _____
Date of purchase: _____
Dealer's name and address: _____

Service

Keep a copy of sales receipt for future reference or in case warranty service is required. To locate an authorized servicer:

- For ACP product call 1-866-426-2621 or visit the Web Site at www.acpsolutions.com

Warranty service must be performed by an authorized servicer. We also recommend contacting an authorized servicer, if service is required after warranty expires.

Parts and Accessories

Purchase replacement parts and accessories over the phone. To order accessories for your product contact your local product distributor or visit the Web site at www.acpsolutions.com.

Unpacking Equipment

- Inspect equipment for damage such as dents in door or dents inside oven cavity.
- Report any dents or breakage to source of purchase immediately. Do not attempt to use oven if damaged.
- Remove all materials from oven interior.

Equipment Placement

- Do not install equipment next to or above source of heat, such as pizza oven or deep fat fryer. This could cause microwave oven to operate improperly and could shorten life of electrical parts.
- Do not block or obstruct air filter. Allow access for cleaning.
- Install on level countertop surface.

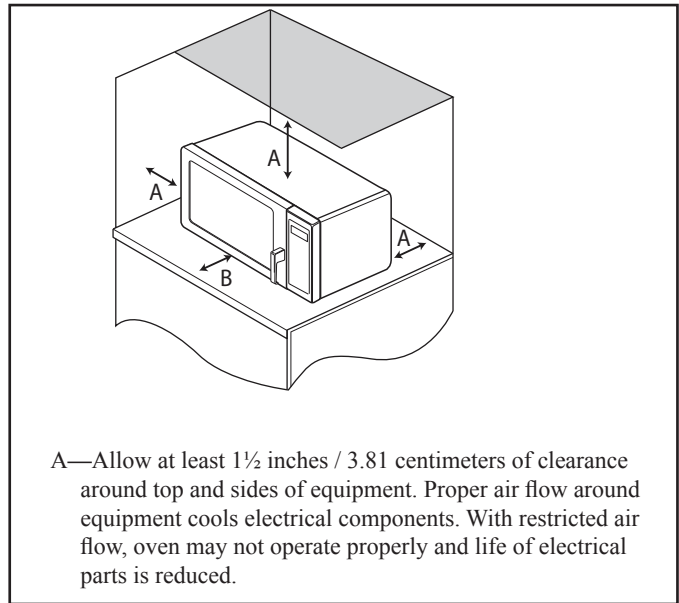

Radio Interference

Microwave operation may cause interference to radio, television, or similar equipment. Reduce or eliminate interference by doing the following:

- Place radio, television, etc. as far as possible from oven.
- Use a properly installed antenna on radio, television, etc. to obtain stronger signal reception.

Troubleshooting Procedures

WHEN YOU GET A COMPLAINT FROM YOUR CUSTOMER, EVALUATE THE COMPLAINT CAREFULLY. IF THE FOLLOWING SYMPTOMS APPLY, PLEASE INSTRUCT THE CUSTOMER IN THE PROPER USE OF THE MICROWAVE OVEN. THIS CAN ELIMINATE AN UNNECESSARY SERVICE CALL.

1. Check grounding before checking for trouble.
2. Be careful of the high voltage circuit.
3. Discharge the high voltage capacitor.
4. When checking the continuity of the switches or of the high voltage transformer, disconnect one lead wire from these parts and then check continuity with the AC plug removed. To do otherwise may result in a false reading or damage to your meter.
5. Do not touch any part of the circuit on the PCB since static electric discharge may damage this control panel.
Always touch yourself to ground while working on this panel to discharge any static charge built up in your body.

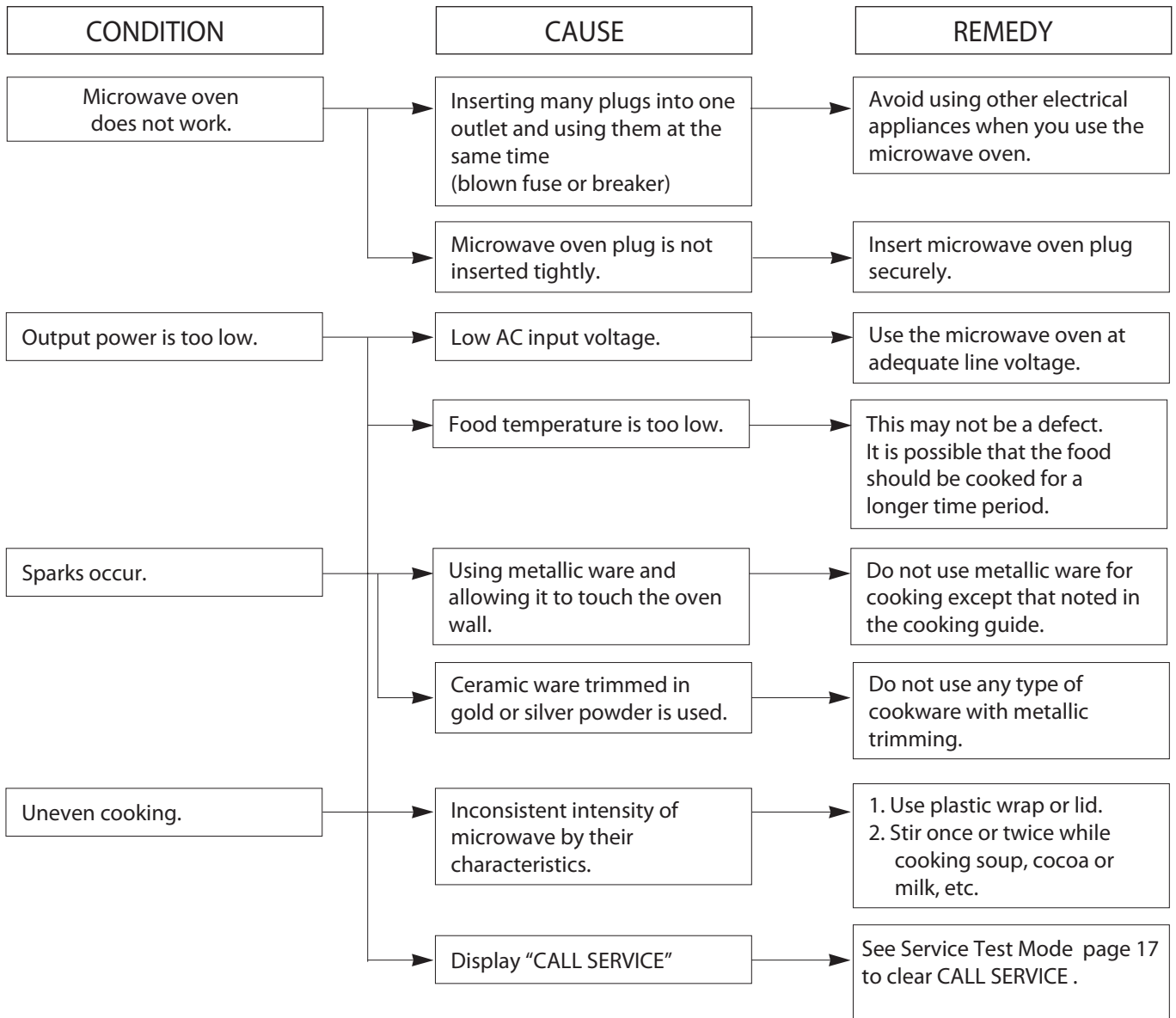

Troubleshooting Procedures

Trouble 1: The following visual conditions indicate a probable failed control circuit.

1. Incomplete segments.
 - Segment missing.
 - Partial segment missing.
 - Digit flickering (Note: Slight flickering is normal.)
2. Colon does not turn on or blink.
3. A distinct change in the brightness of one or more numbers in display.
4. One or more digits in the display are not lighting.
5. Display indicates a number different from one touched, for example, key in 5 and 3 appears in the display.
6. Specific numbers (for example 7 or 9) will not display when key pad is touched.
7. Display does not count down with time blinking or up with clock operation.
8. Display obviously jumps in time while counting down.
9. Display counts down too fast while cooking.
10. Each indicator light does not turn on after setting cooking cycle.
11. Display time of day does not reappear when cooking is finished.

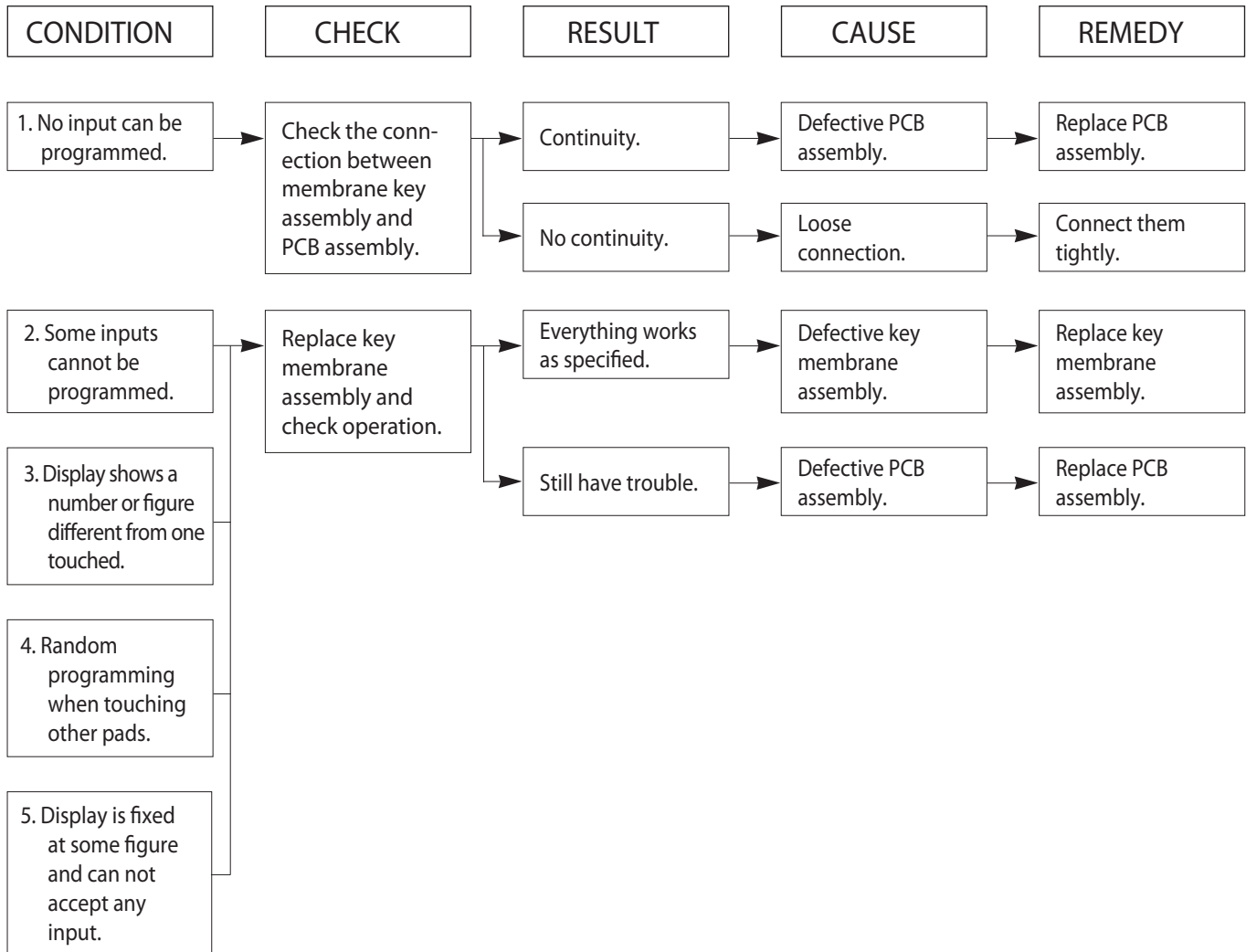

Troubleshooting Procedures

Trouble 2: Oven does not operate at all, Display window does not display any figures, and no input is accepted.

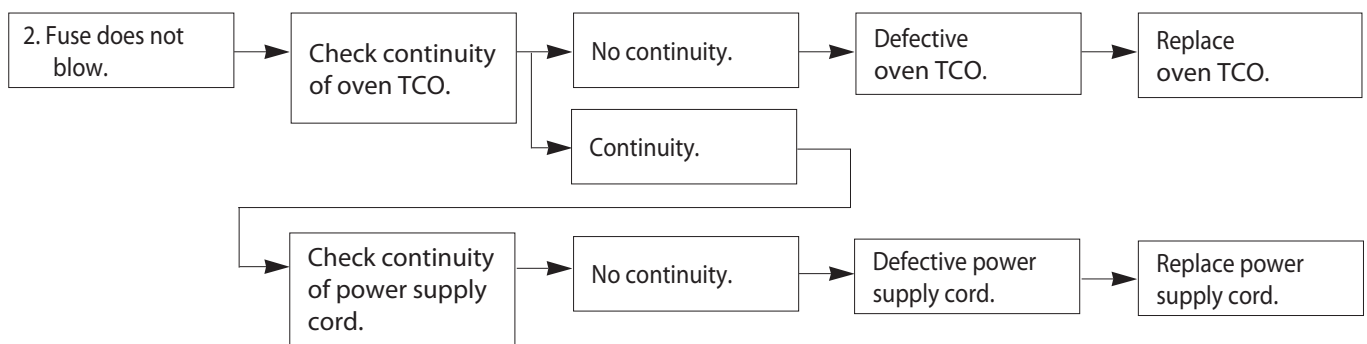
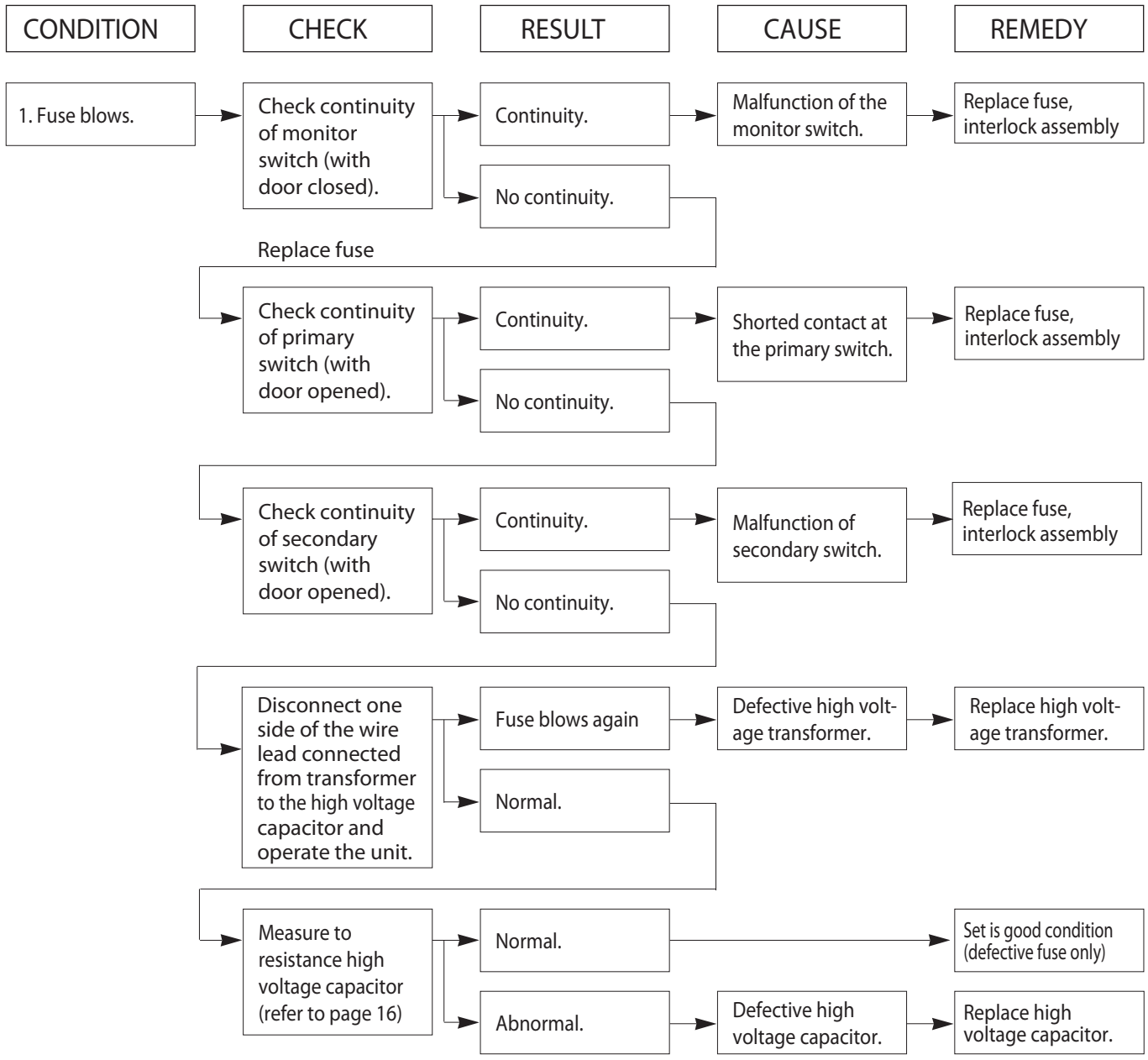

Troubleshooting Procedures

Trouble 3: Display shows all figures set, but oven does not start cooking while desired program times are set and START pad is touched.

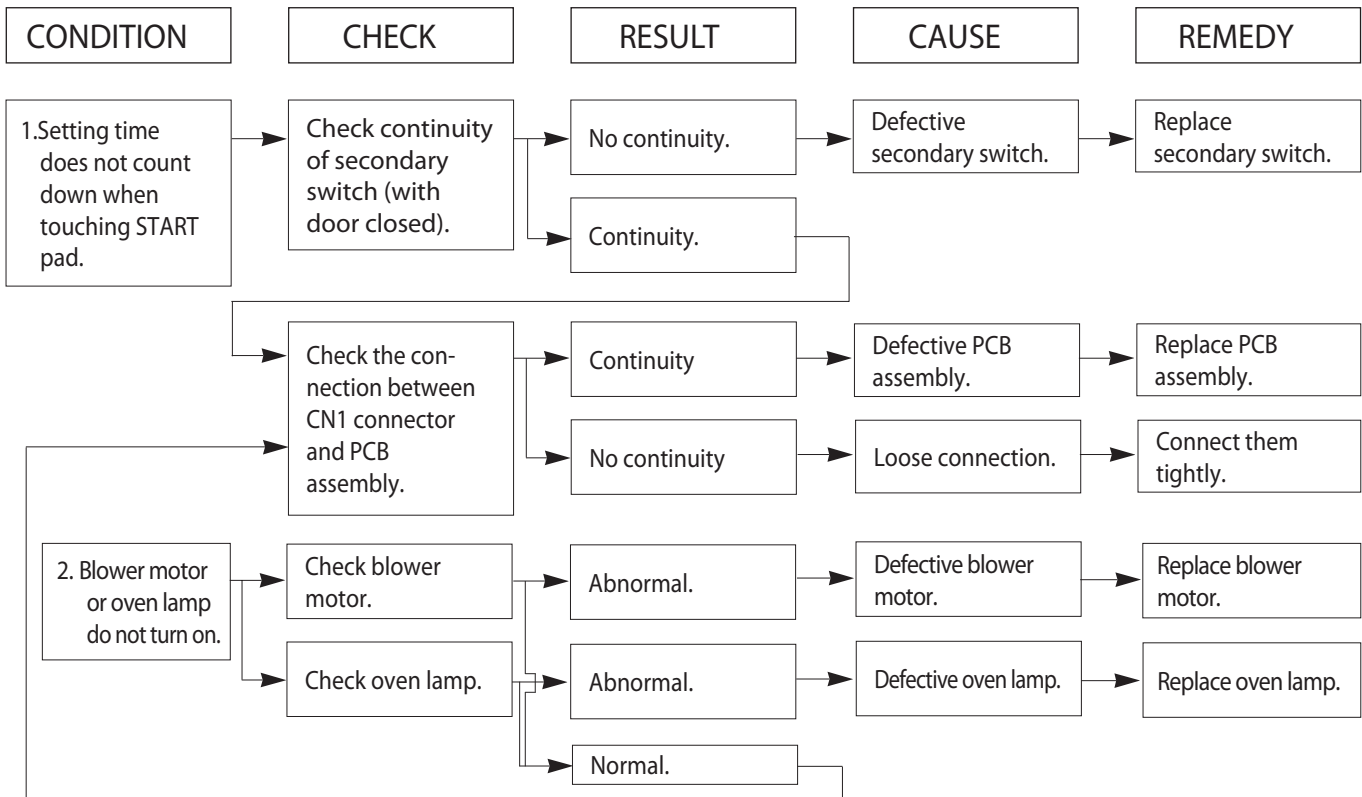

Trouble 4: Oven seems to be operating but little heat is produced in oven load.

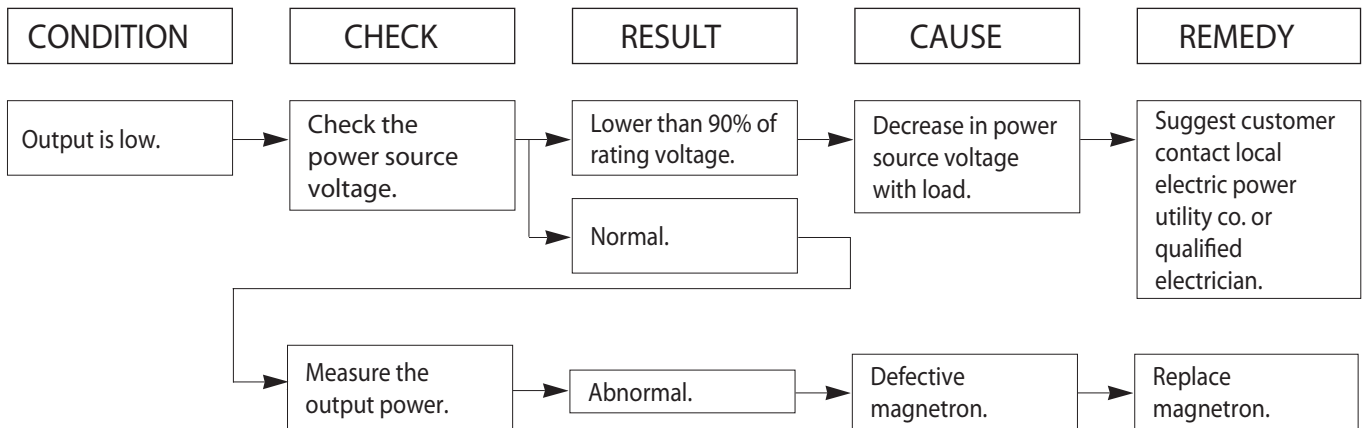

Troubleshooting Procedures

TROUBLE 5: No microwave oscillation even though oven lamp and blower motor run.

(Display operates properly)

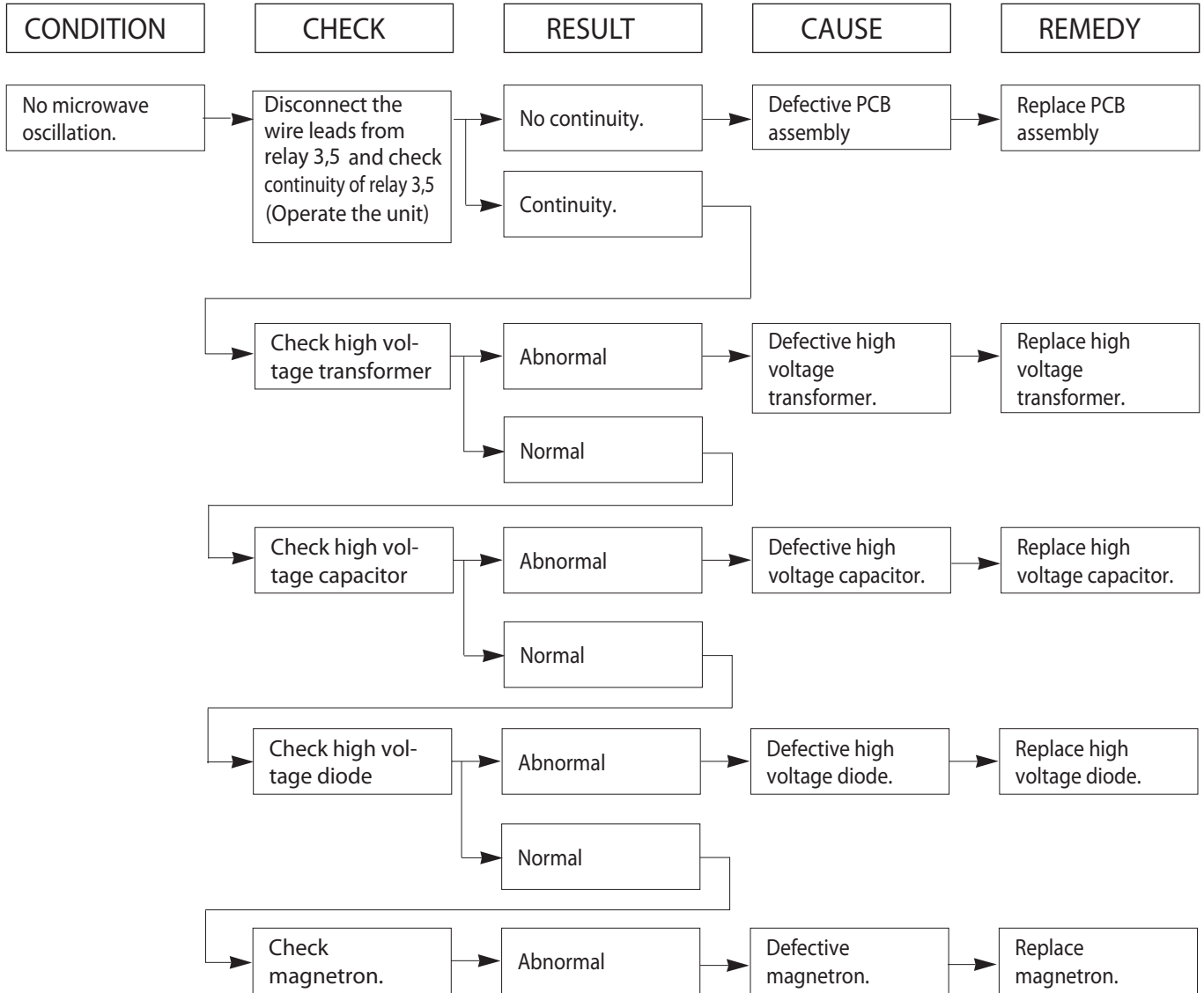

NOTE : • Make sure the wire leads are in the correct position.

- When Removing the wire leads from the parts, be sure to grasp the connector, not the wires.
- When removing the magnetron, be sure to install the magnetron gasket in the correct position and in good condition.

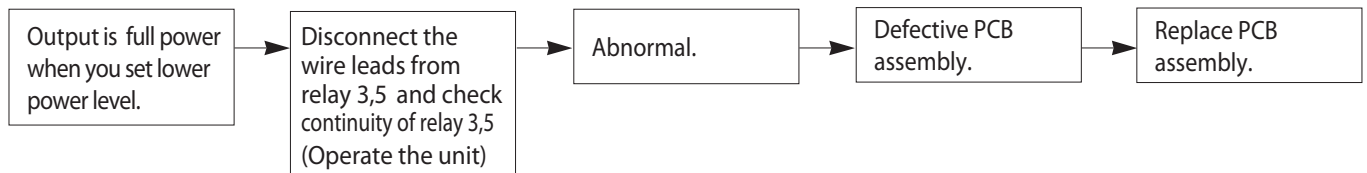

Service Information



WARNING

To avoid risk of electrical shock, personal injury, or death, disconnect power to oven and discharge capacitor before servicing, unless testing requires power.

Proper Handling of Magnetron Tubes



CAUTION

A magnetron tube, like a radio or television tube must be handled with a reasonable amount of care. When handling a tube, always handle by the housing only. Use caution not to touch or strike the ceramic portion at the top. The carton used to ship service replacement tubes is reusable.

Magnetron Failure Modes

Magnetron failures that have been identified are generally grouped into categories shown below.

1. Shorted

Air - This is a case where the tube has had the vacuum envelope destroyed and air has entered the tube. This will cause internal arcing and high secondary current if high voltage is applied.

R.F. Capacitors - May short to chassis. This condition will also cause loss of high voltage.

2. **Open Heater (Filament)** - Can be determined by a ohmmeter when transformer leads are disconnected. Resistance is normally less than one ohm; filament does not short internally. Any tube removed should be checked since usage tends to make the filament more fragile. Later handling and shipping may open the filament and thereby mask the true failure mode when checked at the factory.
3. **Low Power** - Caused by "wearout" of the emission characteristics of the directly heated cathode. Symptoms are: (1) tube current will take longer to get to operating point than a new tube (normally about 2 - 3 seconds), (2) tube current does not get high enough to cause the tube to oscillate with normal line voltage, (3) oven produces low power into a load, two-thirds or less than normal.
4. **Physical Damage** - Caused by mishandling of magnetron tube.

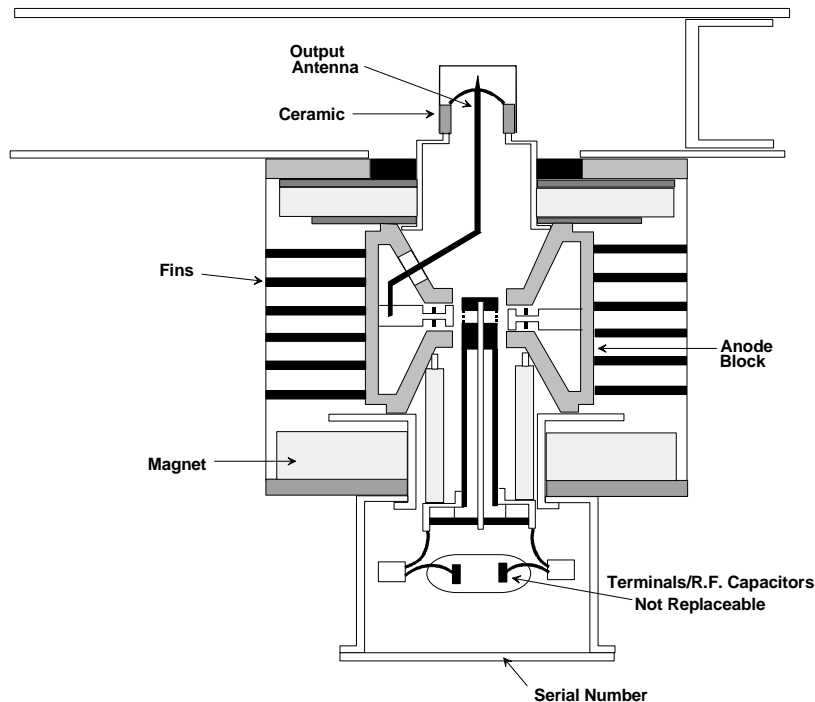

Microwave Leakage Test



WARNING

To avoid risk of electrical shock, personal injury, or death, disconnect power to oven and discharge capacitor before servicing, unless testing requires power.



WARNING

Check for radiation leakage after servicing. Should the leakage be more than 4 mW/cm² inform ACP, Inc. immediately. After repairing or replacing any radiation safety device, keep a written record for future reference, as required by D.H.H.S. and HEW regulations. This requirement must be strictly observed. In addition, the leakage reading must be recorded on the service repair ticket while in the customer's home.

Equipment

- Electromagnetic radiation monitor
- 600 cc glass beaker or plastic power bowl

Procedure for Measuring Radiation Leakage

Note before measuring:

- Do not exceed meter full scale deflection. Leak monitor should initially be set to the highest scale.
 - To prevent false readings the test probe should be held by the grip portion of the handle only.
 - The scan speed is equal to one inch per antenna revolution or one inch per second if antenna speed is unknown.
 - Areas to be checked are all door seal areas and any venting parts.
 - Leakage with the outer panel removed ...4mW/cm² or less.
 - Leakage for fully assembled oven with door normally closed ...4 mW/cm² or less.
 - Leakage for a fully assembly oven (before the latch switch (primary) is interrupted) while pulling the door ... 4 mW/cm² or less.
1. Pour 275 cc ±15 cc (9 oz ±1/2 oz) of 20°C ± 5°C (68°F ± 9°F) water in a beaker which is graduated to 600 cc and place the beaker in the center of oven.
 2. Set the radiation monitor to 2450 MHz and use it following the manufacturer's recommended test procedure to assure correct results.
 3. While measuring the leakage, always use the two inch (5 cm) spacer supplied with the probe.
 4. Press the start pad or turn on the timer and with the magnetron oscillating, measure the leakage by holding the probe perpendicular to the surface being measured.

Measurement with the Outer Panel Removed



WARNING

Avoid contacting any high voltage components.

Whenever you replace the magnetron, measure for radiation leakage before the outer panel is installed and after all necessary components are replaced or adjusted. Special care should be taken in measuring around the magnetron.

Measurement with a Fully Assembled Oven

After all components including the outer panel are fully assembled, measure for radiation leakage around the door periphery, the door viewing window, the exhaust opening, and air inlet openings.





Record Keeping and Notification After Measurement

1. After any adjustment or repair to a microwave oven, a leakage reading must be taken. Record this leakage reading on the repair ticket even if it is zero.
2. A copy of the repair ticket and the microwave leakage reading should be kept by the repair facility.

Testing Procedures

⚠ WARNING

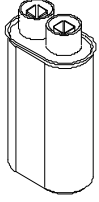
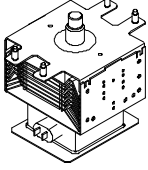
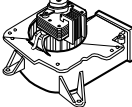
To avoid risk of electrical shock, personal injury or death; disconnect power to oven and discharge capacitor before servicing, unless testing requires power.

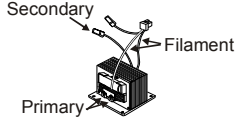
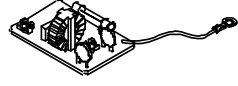
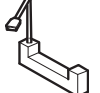
Illustration	Component	Testing	Results
	Thermal cutout	Disconnect all wires from TCO. Measure resistance across terminals. Cavity TCO Magnetron TCO	Closed at 32°F (0°C) and Opens at 230°F (110°C) Closed at 140°F (60°C) and Opens at 320°F (160°C)
	Diode	Discharge Capacitor Remove diode lead from capacitor and connect ohmmeter. Reverse leads for second test.	Infinite resistance should be measured in one direction and 50KΩ or more in the opposite direction. NOTE: Ohmmeter must contain a battery of 6 volts minimum.
	Capacitor	Discharge Capacitor Remove wires from capacitor terminals and connect ohmmeter, set on highest resistance scale to terminals. Also check between each terminal and capacitor case.	Between Terminals: Meter should momentarily deflect towards zero then return to over 5 MΩ. If no deflection occurs, or if continuous deflection occurs, replace capacitor. Terminal to Case: Infinite resistance
	Magnetron	Discharge Capacitor Remove wires from magnetron and connect ohmmeter to terminals. Also check between each terminal and ground.	Between Terminals: Less than 1 Ω Each terminal to ground measures Infinite resistance. Note: This test is not conclusive. If oven does not heat and all other components test good replace the magnetron and retest.
	Blower motor	Remove all wires from motor. Measure resistance across coil	Approximately 28 – 35 Ω
	Stirrer motor	Remove all wires from motor. Measure resistance across terminals	Approximately 12 – 14 KΩ
	Transformer	Discharge Capacitor Remove all wires from terminals. Measure resistance from: Primary Filament..... Secondary to Ground screw on transformer stack.....	Less than <1 Ω Less than <1 Ω Approximately 70 – 80 Ω
	Noise filter board	Power In terminals Power Out terminals	120 VAC 120 VAC If no power in, check power outlet. If no power out, check fuses.
	Circuit Protector	Measure resistance across terminals	Between Terminals: Less than 1 Ω

Testing Procedures



WARNING

To avoid risk of electrical shock, personal injury or death; disconnect power to oven and discharge capacitor before servicing, unless testing requires power.

Illustration	Component	Testing	Results
	Interlock switch assembly	Disconnect wires to switch. With door open measure resistance from: Monitor - Terminal 3 - 4 Primary - Terminal 1 - 2 Secondary - Terminal 5 - 6 With door closed measure resistance from: Monitor - Terminal 3 - 4 Primary - Terminal 1 - 2 Secondary - Terminal 5 - 6 After verifying or replacing the module, reconnect wires to switch and check operation of monitor circuit before operating the oven.	Indicates continuity Infinite Ω Infinite Ω Infinite Ω Indicates continuity Indicates continuity
	Lamp receptacle	Test continuity of receptacle terminals.	Indicates continuity with bulb installed.
	Wire Harness	Test continuity of wires	Indicates continuity

Electronic Control Panel			
	Service Test Mode:	Open door, Press and Hold pad 3 for 5 seconds to enter service test mode. Press Pad 1 Press Pad 2 Press Pad 3 Press Pad 4 Press Pad 5 Press Pad 6 Press Pad 7 Press Pad 8 Press Pad 9 Press Pad 0 Stop/Reset Pad	SERVICE appears in the display Indicates number of hours magnetron has been turned on Indicates number of times magnetron tube has been turned on and off Indicates number of door cycles CLEAR (Press START pad to reset service data.) Indicates amperage N/A RESET (Clear Call Service) N/A N/A N/A Exit Service Test Mode
	Error codes:	E-08 E-09 E-10	Replace Control Board Replace Control Board Shorted or Open Keypad – Test and replace if necessary

Testing Procedures



WARNING

To avoid risk of electrical shock, personal injury or death; disconnect power to oven and discharge capacitor before servicing, unless testing requires power.

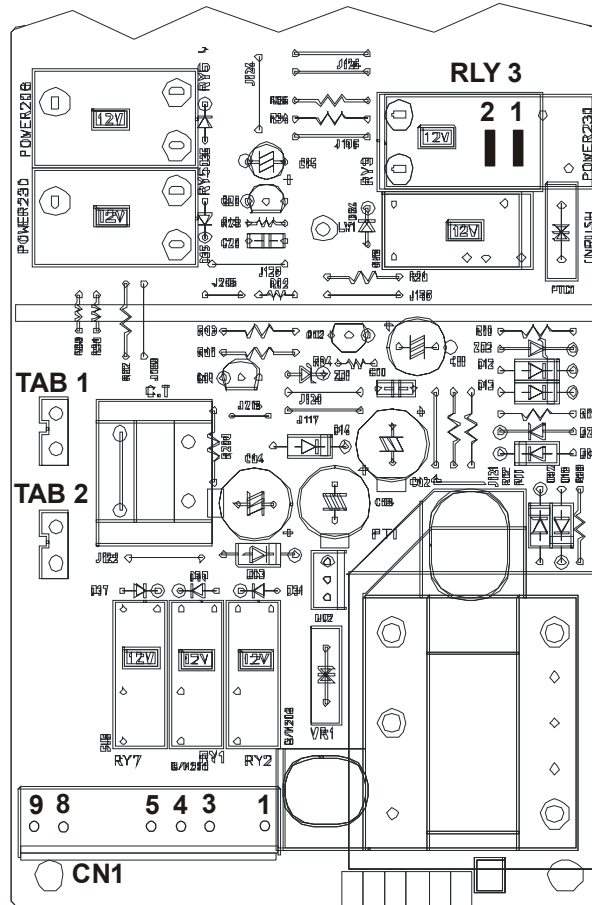

Function	Test Set-Up / Condition	Meter Setting	Probe Placement	Results
Power to current transformer	All Conditions	Volts	Tab 1 to CN1 Pin 3 (Neutral)	120 VAC
Power from current transformer	All Conditions	Volts	Tab 2 to CN1 Pin 3 (Neutral)	120 VAC
Power from Oven TCO	All Conditions	Volts	CN1 – Pin 1 (Black wire to Neutral)	120 VAC
Power to Oven Light	Standby	Volts	CN1 – Pin 4 to Pin 1	120 VAC
	Ready	Volts	CN1 – Pin 4 to Pin 1	0 VAC
	Cook	Volts	CN1 – Pin 4 to Pin 1	0 VAC
Power to Blower Motor	Standby	Volts	CN1 – Pin 5 to Pin 1	120 VAC
	Ready	Volts	CN1 – Pin 5 to Pin 1	0 VAC
	Cook	Volts	CN1 – Pin 5 to Pin 1	0 VAC
Secondary Interlock Switch	Door Closed	Ohms	CN1 – Pin 8 to Pin 9	Continuity
	Door Opened	Ohms	CN1 – Pin 8 to Pin 9	Infinite
Power to Relay 3	Standby	Volts	Relay 3 – Pin 1 to Pin 2	120 VAC
	Ready	Volts	Relay 3 – Pin 1 to Pin 2	120 VAC
	Cook	Volts	Relay 3 – Pin 1 to Pin 2	0 VAC

Testing Procedures



WARNING

To avoid risk of electrical shock, personal injury or death; disconnect power to oven and discharge capacitor before servicing, unless testing requires power.

Power Test

All Amana and Menumaster microwave oven power outputs are rated using the IEC705 standards. Using the IEC705 test method requires precision measurements and equipment that is not practical to be performed in the field. Using the test shown below will indicate if the oven performance is satisfactory.

Test equipment required:

- 1000 ml test container and thermometer.
- Digital watch / watch with a second hand for use on ovens with electromechanical timers.

Important Notes:

- Low line voltage will cause low temperature rise / power output.
- Ovens must be on a dedicated circuit, properly grounded, and polarized. Other equipment on the same circuit may cause a low temperature rise / power output.
- This test and results are not a true IEC705 test procedures and are only intended to provide servicers with an easy means of determining if the microwave oven cooking output is correct.

Procedure

1. Fill the test container to the 1000 ml line with cool tap water.

NOTE: Water temperature should be approximately 60°F / 16°C

2. Using the thermometer, stir water for five to ten seconds; measure, and record the temperature (T1).
3. Place test container of water in the center of oven cavity and close door.
4. Heat the water for a 33-second full power cycle.

NOTE: Use a digital watch or a watch with a second hand for ovens with electromechanical timers.

1. At end of the cycle, remove test container. Using the thermometer, stir water for five to ten seconds and record temperature (T2).
2. Subtract the starting water temperature (T1), from the ending water temperature (T2) to obtain the temperature rise (ΔT).
3. If the temperature rise (ΔT) meets or exceeds the minimum, the test is complete. If the temperature rise (ΔT) fails to meet the minimum temperature rise, test the line voltage to verify it is correct. Then repeat steps 1-6 making sure to change the water. If the temperature rise (ΔT) fails to meet the minimum temperature rise again the oven will require service.

Minimum Temperature Rise at Thirty -Three (33) Seconds Run Time

ΔT (°F)	Cooking Power Output	ΔT (°F)	Cooking Power Output	ΔT (°C)	Cooking Power Output	ΔT (°C)	Cooking Power Output
10	1000	20	2000	5	1000	11	2000
11	1100	21	2100	5.5	1100	11.5	2100
12	1200	22	2200	6.5	1200	12	2200
14	1400	24	2400	7.5	1400	13	2400
17	1700	25	2500	9.5	1700	13.5	2500
18	1800	27	2700	10	1800	15	2700
19	1900	30	3000	10.5	1900	16.5	3000

Disassembly Procedures

WARNING

To avoid the risk of electrical shock, personal injury, or death, disconnect power to oven and discharge the capacitors before following any disassembly procedure.

High voltage is present at the high voltage terminal of the high voltage transformer during any cooking cycle.

It is neither necessary or advisable to attempt measurement of the high voltage.

Before touching any oven components or wiring, always unplug the oven from its power source and discharge capacitor.

Disconnecting Wire Terminals

All wire terminals are locking-type terminals. Proceed as follows to disconnect wire terminals:

Insulated terminals:

Grasp insulator pod and pull back.

DO NOT PULL ON WIRE.

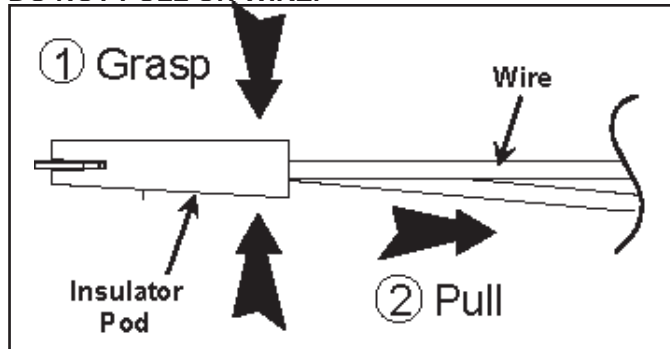

Non-insulated terminals:

Use a small blade screwdriver to depress locking-tab and pull on terminal.

DO NOT PULL ON WIRE.

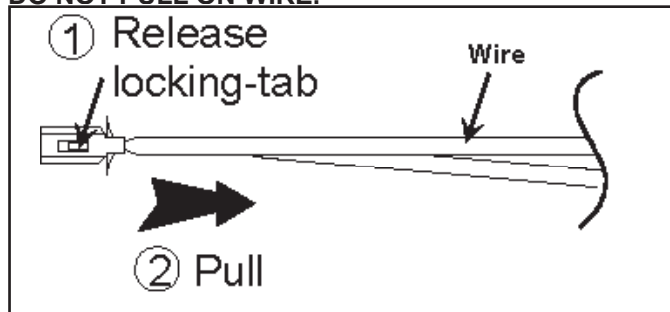

Outer Case

1. Disconnect power to oven.
2. Remove screws securing outer case to unit.
3. Slide outer case towards rear of unit.
4. Reverse procedure to reassemble.

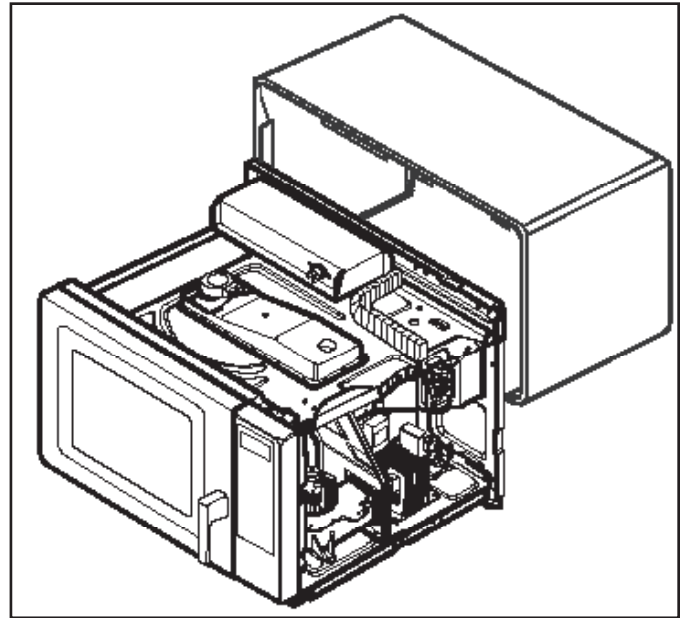

CAUTION

During disassembly some foam gaskets may require removal. These components must be replaced for proper circulation of air over the components and through the oven cavity.

Door Assembly

CAUTION

A microwave leakage test must be performed anytime a door assembly is removed, replaced, disassembled, or adjusted for any reason.

Disassembly Procedures



WARNING

To avoid the risk of electrical shock, personal injury, or death, disconnect power to oven and discharge the capacitors before following any disassembly procedure.

Door Removal

1. Disconnect power to oven.
2. Open oven door, remove top hinge cap, and slowly lift door to disengage the hinge pins at top and bottom.

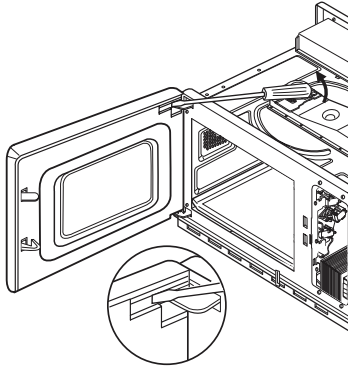

3. To reinstall door, place top pin into slot first, then align bottom pin.
4. Reinstall top hinge cap.

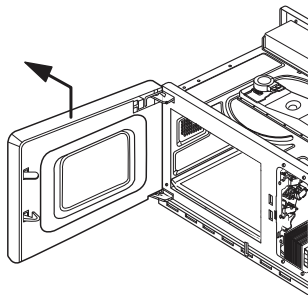

Door Disassembly

1. Disconnect power to oven.
2. Remove oven door, (see "Door Removal").
3. Begin at the bottom of the door near hinge, insert flat blade screwdriver between choke cover and outer door panel. Gently pry upward on choke cover to release tabs. Work in clockwise direction to remove choke cover.



CAUTION

To avoid property damage, care must be taken when prying choke cover from oven door.

4. Remove screw securing door handle to latch assembly.
5. Slide latch assembly downward and pull away from door frame to release.
6. Remove screws securing choke assembly to outer door panel.

NOTE: When disassembling door, use caution to prevent deformation of slats on door frame/choke assembly.

7. Begin at hinge side of door near bottom, insert flat blade screwdriver between door frame/choke assembly and outer door panel. Gently pry outer door panel away from door frame to release tabs. Work in clockwise direction to remove door frame.
8. Remove spring from hinge assembly.
9. Remove screws securing hinge assembly to choke assembly.
10. Reassemble in reverse order.

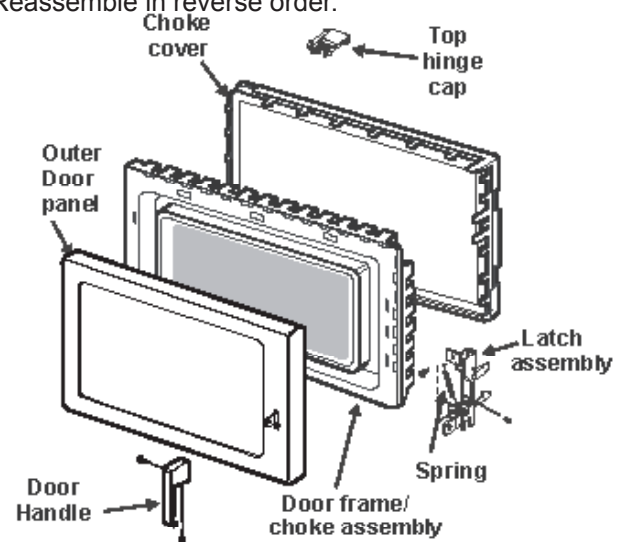

* Tighten side screw first and apply Loctite



CAUTION

A microwave leakage test must be performed anytime a door assembly is removed, replaced, disassembly, or adjusted for any reason.

Disassembly Procedures



WARNING

To avoid the risk of electrical shock, personal injury, or death, disconnect power to oven and discharge the capacitors before following any disassembly procedure.

Control Panel Removal

1. Disconnect power to oven and remove outer case, (see "Outer Case" procedure).
2. Disconnect and label wires from controller/timer.
3. Open oven door.
4. Remove screws securing top and bottom of control panel to cavity. Lift control panel up and out to release tabs.

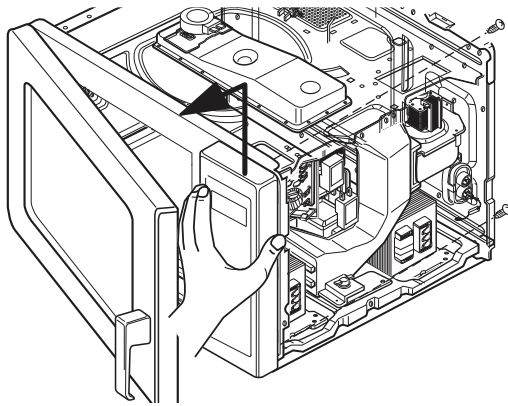

5. Replace component and reverse procedure to reassemble.

Interlock Switches

Primary switch is operated by bottom latch arm.

Interlock Switch Removal

1. Disconnect power to oven and remove outer case, (see "Outer Case" procedure).
2. Remove control panel, (see "Control Panel" section).
3. Test interlock switches before removing, (see testing procedures).

4. Disconnect and label wire connections.
5. Remove mounting screws securing interlock switch to unit chassis.
6. Remove interlock from unit chassis

ADJUSTMENT
DIRECTION



MONITOR
SWITCHES

PRIMARY
SWITCHES

SECONDARY
SWITCH

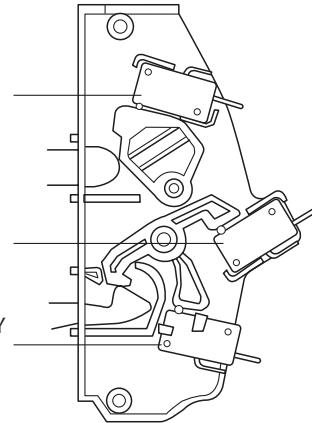

NOTE: After repairing the door or the interlock system, it is necessary to check the switch continuity before operating the oven.



CAUTION

Before replacing a blown monitor fuse, test the primary interlock switch, secondary interlock switch, monitor switch, and power relay contacts for proper operation. If the monitor fuse is blown by a failed switch operation, interlock assembly must be replaced.

Adjusting Interlocks

The interlock monitor, primary, and secondary switches act as a final safety switch, protecting the operator from microwave energy. After adjusting the interlock switch assembly, verify wires are correctly connected.

For door fit and switch operation, switch bracket is adjustable.

Disassembly Procedures



WARNING

To avoid the risk of electrical shock, personal injury, or death, disconnect power to oven and discharge the capacitors before following any disassembly procedure.

1. Disconnect power to oven and remove outer case, (see "Outer Case" procedure).
2. Loosen switch bracket mounting screws.
3. Close oven door, move switch bracket toward rear of oven until door gap is less than $\frac{1}{64}$ -inch (0.5 mm).
4. Hold switch bracket securely for proper switch operation and door fit, retighten screws.
5. Open oven door slowly, watching the switches. Verify switches release in the following order.
 - Primary interlock switch
 - Secondary interlock switch
 - Interlock monitor switch

NOTE: Adjust the switch bracket until all switches operate in proper sequence.

6. Close the oven door slowly, watching the switches. Verify switches activate in the following order.
 - Interlock monitor switch
 - Secondary interlock switch
 - Primary interlock switch
7. When proper switch sequence has been achieved, tighten the switch bracket securely.



CAUTION

A microwave leakage test must be performed anytime a door assembly is removed, replaced, disassembled, or adjustment of switch bracket is performed.

High Voltage Capacitor

High voltage capacitors should always be discharged by shorting a terminal to a chassis ground. The capacitor has a internal "shunt" resistor, but the mechanical discharge should always be performed to avoid personal injury.

High Voltage Capacitor Removal

1. Disconnect power to oven and remove outer case, (see "Outer Case" procedure).
2. Discharge high voltage capacitors.
3. Remove and label wire leads from capacitor terminals.

4. Remove screw securing capacitor strap to plate.
5. Slide capacitor out of capacitor strap and remove capacitor.
6. Replace capacitor and reverse procedure to reassemble.

NOTE: When replacing H.V. components, route H.V. wires at least $\frac{1}{4}$ " / 6 mm from all grounded surfaces to prevent arcing.

Diode

1. Disconnect power to oven and remove outer case, (see "Outer Case" procedure).
2. Discharge high voltage capacitor, (see "High Voltage Capacitor" section).
3. Disconnect diode from high voltage capacitor and remove screw securing diode to ground.
4. Replace diode and reverse procedure to reassemble.

Transformer

1. Disconnect power to oven and remove outer case, (see "Outer Case" procedure).
2. Discharge high voltage capacitor, (see "High Voltage Capacitor" section).
3. Disconnect and label wire leads from transformer.
4. Remove screws securing transformer and remove.
5. Replace transformer and reverse procedure to reassemble.

Fuse / Fuse Block / Filter Assembly

1. Disconnect power to oven and remove outer case, (see "Outer Case" section).
2. Disconnect and label wires.
3. Remove fuses to gain access to screws securing assembly.
4. Carefully lift tab to release assembly from locating pin.
5. Replace component(s) and reverse procedure to reassemble.



CAUTION

Before replacing a blown monitor fuse, test the primary interlock switch, secondary interlock switch, monitor switch, and power relay contacts for proper operation. If the monitor fuse is blown by a failed switch operation, interlock assembly must be replaced.

Disassembly Procedures



WARNING

To avoid the risk of electrical shock, personal injury, or death, disconnect power to oven and discharge the capacitors before following any disassembly procedure.

Magnetron

Magnetron is located on the side of the cavity.

1. Disconnect power to oven and remove outer case, (see "Outer Case" section).
2. Discharge high voltage capacitor, (see page 16 capacitor testing procedures).
3. Remove blower motor assembly (see "Blower Motor" procedure).
4. Remove terminal plug from filament terminals.
5. Remove screws securing magnetron cutout bracket to magnetron.
6. Remove screws securing magnetron to the wave guide.

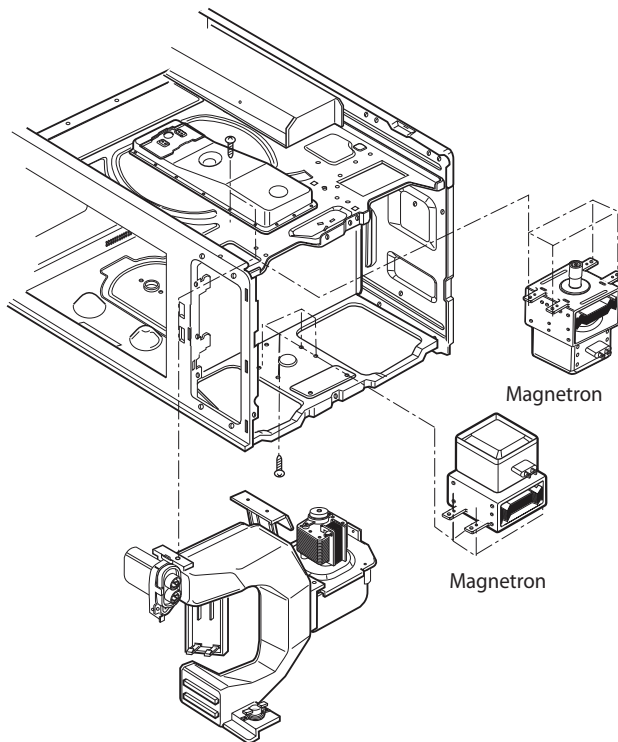

Blower Motor

1. Disconnect power to oven and remove outercase, (see "Outer Case" procedure).
2. Remove outer case.
3. Disconnect wiring from blower motor, fuse block and lower magnetron tco.
4. Remove the two screws holding the blower motor bracket to the upper plate.
5. Remove the screw holding the blower motor bracket to the back cover.
6. Remove the upper screw holding the high voltage capacitor bracket.
7. Remove the lower screw holding the duct assembly.

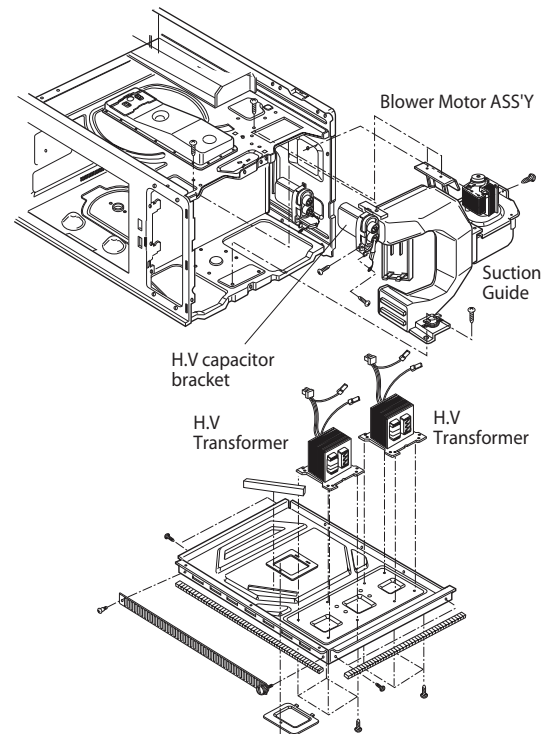

7. Replace magnetron and reverse procedure to reassemble.

NOTE: When replacing magnetron, make sure gasket is in correct position and in good condition.



CAUTION

During replacement of magnetron, be certain the R.F. anode gasket is in place around the anode stud.



WARNING

A microwave leakage test must be performed anytime a magnetron assembly is removed, replaced, disassembled, or adjusted for any reason.

Disassembly Procedures



WARNING

To avoid the risk of electrical shock, personal injury, or death, disconnect power to oven and discharge the capacitors before following any disassembly procedure.

Splatter Shield

NOTE: Be careful not to bend antenna when removing splatter shield. Shield snaps into a lip in front of the oven and three slots in the back.

1. Place your thumbs in the two indentations in front of the shield.
2. Press lightly towards the back and carefully lower shield away from antenna.
3. Pull shield out of the back slots and out of the oven.

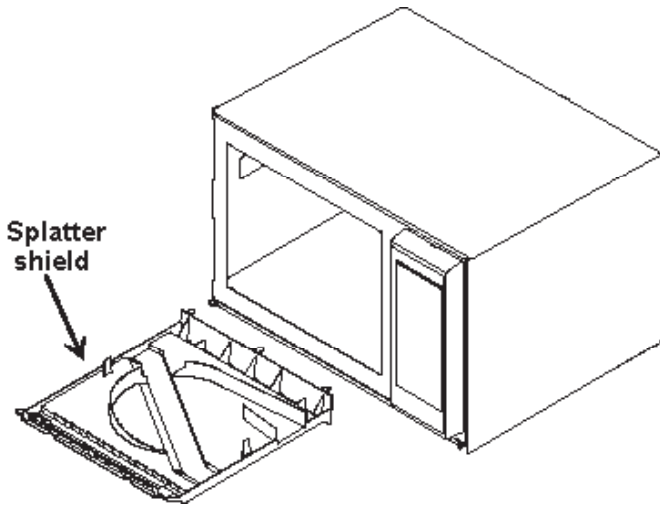

Upper Antenna

1. Remove splatter shield from oven cavity.
2. Remove two mounting rivets on the top of oven cavity to remove cradle. Support cradle before removing mounting rivets to avoid damage to antenna assembly.

Lower Antenna

1. Open oven door.
2. Using a suction cup to pry upward on front portion and remove tray from unit.
3. Remove two mounting rivets on the bottom of oven cavity floor to remove cradle. Support cradle before removing mounting rivets to avoid damage to antenna assembly.

Stirrer Motor

1. Disconnect power to oven and remove outer case, (see "Outer Case" procedure).
2. Remove outer case.
3. Disconnect the leadwire from the stirrer fan motor terminals.
4. Remove screws securing stirrer motor to wave guide.
5. Replace component and reverse procedure to reassemble.

NOTE: When replacing stirrer motor, verify motor shaft is aligned with antenna shaft before securing with screws.

Lower Stirrer Motor

1. Lay the unit down on its back.
2. Remove the screw securing the base cover.
3. Remove the screw securing the stirrer fan motor to the oven cavity assembly.
4. After repairing the motor, replace the removed base cover.
5. The taptite screw shall be used when a turntable motor cover is secured with a screw.

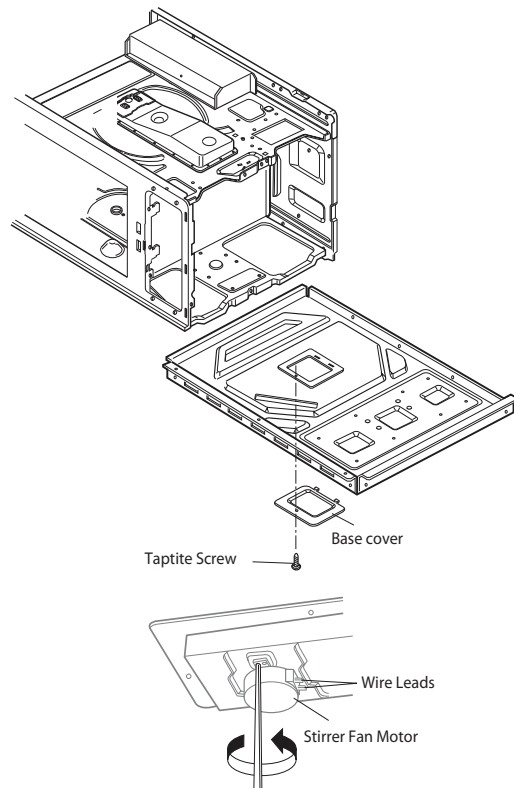

Disassembly Procedures



WARNING

To avoid the risk of electrical shock, personal injury, or death, disconnect power to oven and discharge the capacitors before following any disassembly procedure.

Magnetron Thermal Cut-Out (TCO)

1. Disconnect power to oven and remove outer case, (see "Outer Case" procedure).
2. Remove outer case.
3. Remove TCO by removing screws.
4. Disconnect wiring.
5. Replace component and reverse procedure to reassemble.

NOTE: When reconnecting wiring to thermal fuses the connectors must be tight.

Cavity Thermal Fuse

1. Disconnect power to oven and remove outer case, (see "Outer Case" procedure).
2. Remove outer case.
3. Remove thermal fuse mounting screw.
4. Disconnect wiring.
5. Replace component and reverse procedure to reassemble.

NOTE: When reconnecting wiring to thermal fuses the connectors must be tight.

Tray Replacement

1. Unplug oven from outlet.
2. Using a suction cup to pry upward on front portion and remove tray from unit.
3. Thoroughly clean and degrease sump area.
4. Clean oven cavity bottom where new oven tray will make contact using mineral spirits or any non-flammable degreasing solvent.

NOTE: Detergents, soap, and water are not sufficient to remove oil and grease.

5. Place new tray into unit and clean cavity with mild detergent to remove any remaining degreasing solvent.

Oven Light Removal

The light bulb for inside of the oven can be changed only from the side of the unit. On the left hand side of the oven is a metal plate with one screw. The light bulb is located behind this plate.

Follow these steps to change the bulb:

1. Disconnect power to oven and remove outer case, (see "Outer Case" procedure).
2. Remove screw and plate from side of unit.
3. To remove bulb, turn it counterclockwise, being careful not to burn fingers or break the bulb.
4. Replace bulb with a 40 watt, 115 - 125 volt bulb.
5. Reposition plate, being careful not to bend hinge tab. Replace and tighten screw. Do not operate oven without plate in place.