

# Commercial Microwave—Technical Information

## 120 V, 60 Hz Models

**RFS12MPSB P1330235M**  
**RFS12SW2C P1330237M**

**RFS12SW2B P1330236M**

- Due to possibility of personal injury or property damage, always contact an authorized technician for servicing or repair of this unit.
- Refer to Service Manual 16400007 for installation, operating, testing, troubleshooting, and disassembly instruction.



### CAUTION

All safety information must be followed as provided in Service Manual 16400007.



### WARNING







To avoid the risk of electrical shock, personal injury or death, disconnect power to oven and discharge capacitor before servicing, unless testing requires it.

Models	RFS12MPSB, RFS12SW2B RFS12SW2C	
<b>Power Source</b>		
Voltage AC	120 VAC	
Amperage (Single Unit)	20 A	
Frequency	60 Hz	
Single Phase, 3 wire grounded	X	
Receptacle	5-20R	
Plug	5-20P	
<b>Power Output</b>		
Nominal microwave energy (IEC705)	1200 Watts	
Minimum temperature rise ( $\Delta T$ )	12°F / 6.5°C	
Operating Frequency	2450 MHz	
<b>Power Consumption</b>		
Cook Condition Microwave	1800 Watts / 15.8 Amps	
<b>Dimensions</b>		
<b>Cabinet</b>		
Width	21 3/4"	55 cm
Height	14 1/4"	36.2 cm
Depth	20 1/4"	51.4 cm
<b>Oven Interior</b>		
Width	14 1/4"	36.2 cm
Height	9"	22.6 cm
Depth	16 3/8"	41.6 cm
<b>Weight</b>		
Crated	71 lbs.	32 kg
Uncrated	64 lbs.	29 kg

# Component Testing Procedures

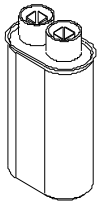
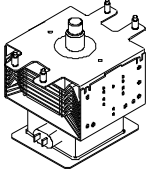
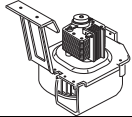
## ⚠ WARNING

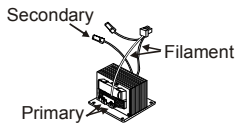
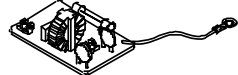
To avoid risk of electrical shock, personal injury or death, disconnect power to oven and discharge capacitor before servicing, unless testing requires it.

Illustration	Component	Testing	Results
	Thermal cutout	Disconnect all wires from TCO. Measure resistance across terminals. Cavity TCO ..... Magnetron TCO .....	Closed at 32°F (0°C) and Opens at 230°F (110°C) Closed at 140°F (60°C) and Opens at 320°F (160°C)
	Diode	<b>Discharge Capacitor</b>  Remove diode lead from capacitor and connect ohmmeter.  Reverse leads for second test.	Infinite resistance should be measured in one direction and 50KΩ or more in the opposite direction.  <b>NOTE:</b> Ohmmeter must contain a battery of 6 volts minimum.
	Capacitor	<b>Discharge Capacitor</b>  Remove wires from capacitor terminals and connect ohmmeter, set on highest resistance scale to terminals.  Also check between each terminal and capacitor case.	Between Terminals: Meter should momentarily deflect towards zero then return to over 5 MΩ. If no deflection occurs, or if continuous deflection occurs, replace capacitor.  Terminal to Case: Infinite resistance
	Magnetron	<b>Discharge Capacitor</b>  Remove wires from magnetron and connect ohmmeter to terminals. Also check between each terminal and ground.	Between Terminals: Less than 1 Ω  Each terminal to ground measures Infinite resistance. <b>Note:</b> This test is not conclusive. If oven does not heat and all other components test good replace the magnetron and retest.
	Blower motor	Remove all wires from motor.  Measure resistance across coil .....	Approximately 28 – 35 Ω
	Stirrer motor	Remove all wires from motor.  Measure resistance across terminals .....	Approximately 12 – 14 KΩ
	Transformer	<b>Discharge Capacitor</b> Remove all wires from terminals.  Measure resistance from: Primary ..... Filament..... Secondary to Ground screw on transformer stack.....	Less than <1 Ω Less than <1 Ω  Approximately 90-80 Ω
	Noise filter board	Power In terminals ..... Power Out terminals .....	120 VAC 120 VAC If no power in, check power outlet. If no power out, check fuses.
	Circuit Protector	Measure resistance across terminals .....	Between Terminals: Less than 1 Ω

# Component Testing Procedures



## WARNING

To avoid risk of electrical shock, personal injury or death, disconnect power to oven and discharge capacitor before servicing, unless testing requires it.

Illustration	Component	Testing	Results
	<p>Interlock switch assembly</p>	<p>Disconnect wires to switch.</p> <p>With door open measure resistance from:            Top Monitor – COM (PK) – NO (BL).....            Btm Monitor – COM (WH) – NO (RD).....            Top Primary – COM (RD BK) – NC (BN)            Btm Primary – COM (BK) – NC (BL).....            Secondary – COM (PK) – NC (GN).....</p> <p>With door closed measure resistance from:            Top Monitor – COM (PK) – NO (BL).....            Btm Monitor – COM (WH) – NO (RD).....            Top Primary – COM (RD BK) – NC (BN)            Btm Primary – COM (BK) – NC (BL).....            Secondary – COM (PK) – NC (GN).....</p> <p><b>After verifying or replacing the module, reconnect wires to switch and check operation of monitor circuit before operating the oven.</b></p>	<p>Indicates continuity            Indicates continuity            Infinite Ω            Infinite Ω            Infinite Ω</p> <p>Infinite Ω            Infinite Ω            Indicates continuity            Indicates continuity            Indicates continuity</p>
	Lamp receptacle	Test continuity of receptacle terminals.	Indicates continuity with bulb installed.
	Wire Harness	Test continuity of wires	Indicates continuity

Electronic Control Panel			
	<p><b>Service Test Mode:</b></p>	<p><b>Open door, Press and Hold pad 3 for 5 seconds to enter service test mode.</b></p> <p>Press Pad 1.....</p> <p>Press Pad 2.....</p> <p>Press Pad 3.....</p> <p>Press Pad 4.....</p> <p>Press Pad 5.....</p> <p>Press Pad 6.....</p> <p>Press Pad 7.....</p> <p>Press Pad 8.....</p> <p>Press Pad 9.....</p> <p>Press Pad 0.....</p> <p>Stop/Reset Pad.....</p>	<p>SERVICE appears in the display</p> <p>Indicates number of hours magnetron has been turned on</p> <p>Indicates number of times magnetron tube has been turned on and off</p> <p>Indicates number of door cycles</p> <p>CLEAR (Press START pad to reset service data.)</p> <p>Indicates amperage (Top Mag)</p> <p>Indicates amperage (Bottom Mag)</p> <p>RESET (Clear Service Alarm)</p> <p>N/A</p> <p>N/A</p> <p>N/A</p> <p>Exit Service Test Mode</p>
	<p><b>Error codes:</b></p>	<p><b>E-08</b>.....</p> <p><b>E-09</b>.....</p> <p><b>E-10</b>.....</p>	<p>Replace Control Board</p> <p>Replace Control Board</p> <p>Shorted or Open Keypad – Test and replace if necessary</p>

# Component Testing Procedures

## **WARNING**

To avoid risk of electrical shock, personal injury or death, disconnect power to oven and discharge capacitor before servicing, unless testing requires it.

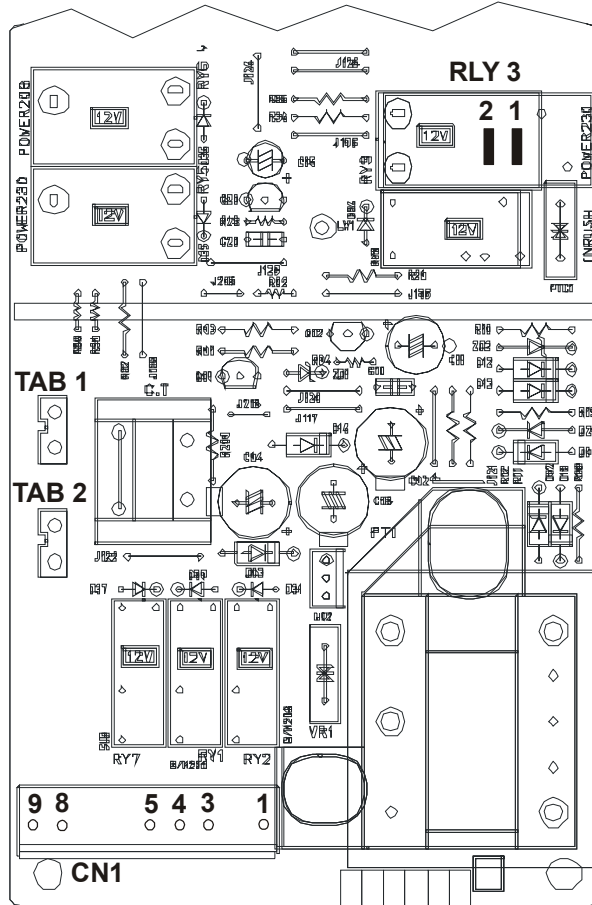

Function	Test Set-Up / Condition	Meter Setting	Probe Placement	Results
Power to current transformer	All Conditions	Volts	Tab 1 to CN1 Pin 3 (Neutral)	120 VAC
Power from current transformer	All Conditions	Volts	Tab 2 to CN1 Pin 3 (Neutral)	120 VAC
Power from Oven TCO	All Conditions	Volts	CN1 – Pin 1 (Black wire to Neutral)	120 VAC
Power to Oven Light	Standby .....	Volts	CN1 – Pin 4 to Pin 1 .....	120 VAC
	Ready .....	Volts	CN1 – Pin 4 to Pin 1 .....	0 VAC
	Cook .....	Volts	CN1 – Pin 4 to Pin 1 .....	0 VAC
Power to Blower Motor	Standby .....	Volts	CN1 – Pin 5 to Pin 1 .....	120 VAC
	Ready .....	Volts	CN1 – Pin 5 to Pin 1 .....	0 VAC
	Cook .....	Volts	CN1 – Pin 5 to Pin 1 .....	0 VAC
Secondary Interlock Switch	Door Closed .....	Ohms	CN1 – Pin 8 to Pin 9 .....	Continuity
	Door Opened .....	Ohms	CN1 – Pin 8 to Pin 9 .....	Infinite
Power to Relay 3	Standby .....	Volts	Relay 3 – Pin 1 to Pin 2 .....	120 VAC
	Ready .....	Volts	Relay 3 – Pin 1 to Pin 2 .....	120 VAC
	Cook .....	Volts	Relay 3 – Pin 1 to Pin 2 .....	0 VAC

# Component Testing Procedures



## WARNING

To avoid risk of electrical shock, personal injury or death, disconnect power to oven and discharge capacitor before servicing, unless testing requires it.

All Amana and Menumaster microwave oven power outputs are rated using the IEC705 standards. Using the IEC705 test method requires precision measurements and equipment that is not practical to be performed in the field. Using the test shown below will indicate if the oven performance is satisfactory.

### Test equipment required:

- 1000 ml test container and thermometer.
- Digital watch / watch with a second hand for use on ovens with electromechanical timers.

### Important Notes:

- Low line voltage will cause low temperature rise / power output.
- Ovens must be on a dedicated circuit, properly grounded, and polarized. Other equipment on the same circuit may cause a low temperature rise / power output.
- This test and results are not a true IEC705 test procedures and are only intended to provide servicers with an easy means of determining if the microwave oven cooking output is correct.

### Procedure

1. Fill the test container to the 1000 ml line with cool tap water.

**NOTE:** Water temperature should be approximately 60°F / 16°C

2. Using the thermometer, stir water for five to ten seconds; measure, and record the temperature (T1).
3. Place test container of water in the center of oven cavity and close door.
4. Heat the water for a 33-second full power cycle.

**NOTE:** Use a digital watch or a watch with a second hand for ovens with electromechanical timers.

5. At end of the cycle, remove test container. Using the thermometer, stir water for five to ten seconds and record temperature (T2).
6. Subtract the starting water temperature (T1), from the ending water temperature (T2) to obtain the temperature rise ( $\Delta T$ ).
7. If the temperature rise ( $\Delta T$ ) meets or exceeds the minimum, the test is complete. If the temperature rise ( $\Delta T$ ) fails to meet the minimum temperature rise, test the line voltage to verify it is correct. Then repeat steps 1 - 6 making sure to change the water. If the temperature rise ( $\Delta T$ ) fails to meet the minimum temperature rise again the oven will require service.

**Minimum Temperature Rise at Thirty -Three (33) Seconds Run Time**

$\Delta T$ (°F)	Cooking Power Output	$\Delta T$ (°F)	Cooking Power Output	$\Delta T$ (°C)	Cooking Power Output	$\Delta T$ (°C)	Cooking Power Output
10.....	1000	20 .....	2000	5 .....	1000	11 .....	2000
11.....	1100	21 .....	2100	5.5 .....	1100	11.5 .....	2100
12.....	1200	22 .....	2200	6.5 .....	1200	12 .....	2200
14.....	1400	24 .....	2400	7.5 .....	1400	13 .....	2400
17.....	1700	25 .....	2500	9.5 .....	1700	13.5 .....	2500
18.....	1800	27 .....	2700	10 .....	1800	15 .....	2700
19.....	1900	30 .....	3000	10.5 .....	1900	16.5 .....	3000

# Wiring and Schematic Diagrams



**WARNING**

To avoid risk of electrical shock, personal injury or death, disconnect power to oven and discharge capacitor before servicing, unless testing requires it.

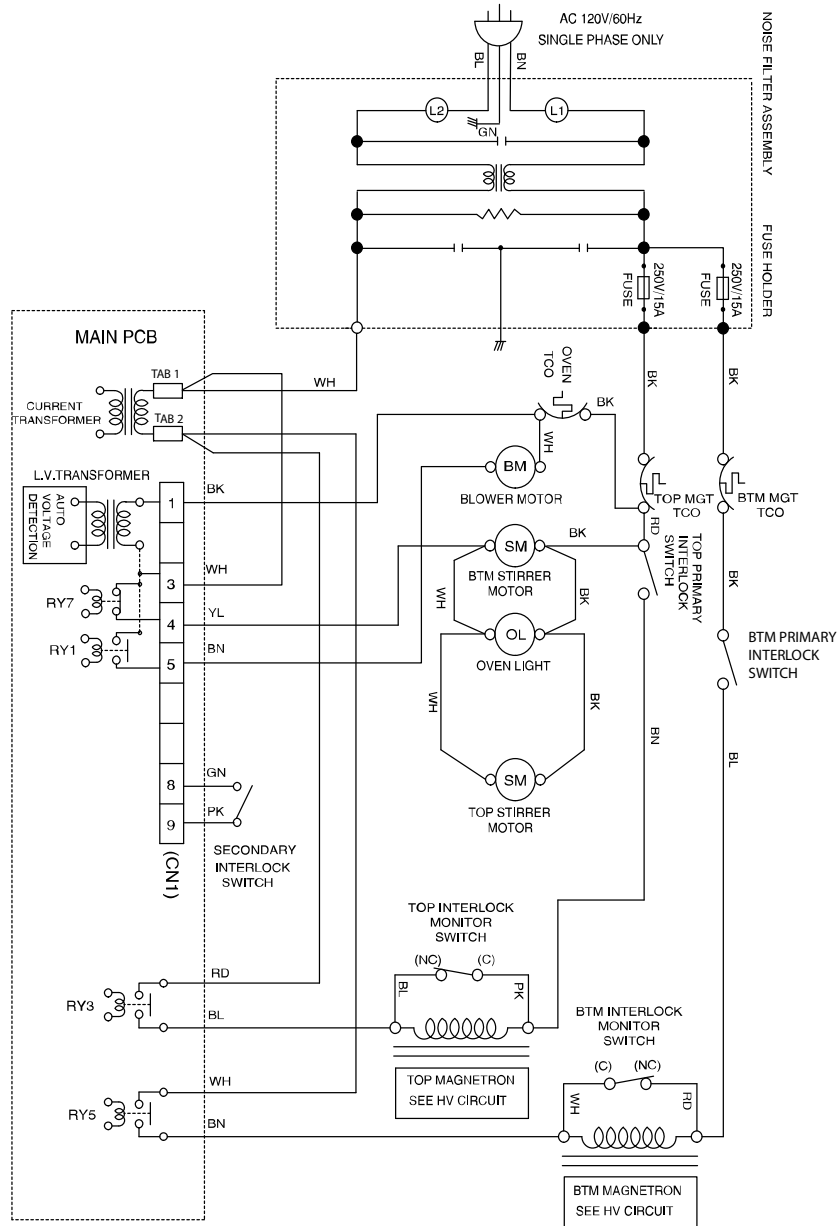

NOTE:  
1. DOOR IS OPENED.  
2. WIRE COLOR

SYMBOL	COLOR
BK	BLACK
BN	BROWN
BL	BLUE
GN	GREEN
PK	PINK
RD	RED
WH	WHITE
YL	YELLOW

