

Commercial Microwave—Technical Information

120 V, 60 Hz Models

HDC12A2 P1331203M

- Due to possibility of personal injury or property damage, always contact an authorized technician for servicing or repair of this unit.
- Refer to Service Manual RS2240002 for installation, operating, testing, troubleshooting, and disassembly instruction.



CAUTION

All safety information must be followed as provided in Service Manual RS2240002.



WARNING

To avoid the risk of electrical shock, personal injury or death; disconnect power to oven and discharge capacitor before servicing, unless testing requires it.



Models	HDC12A2
Power Source	
Voltage AC	120 VAC
Amperage (Single Unit)	20 A
Frequency	60 Hz
Single Phase, 3 wire grounded	X
Receptacle	5-20R
Plug	5-20P
Power Output	
Nominal microwave energy (IEC705)	1200 Watts
Minimum temperature rise (ΔT)	12°F / 6.5°C
Operating Frequency	2450 MHz
Power Consumption	
Cook Condition Microwave	1900 Watts
Dimensions	
Cabinet	
Width	16 3/4" (42.5 cm)
Height	13 1/2" (34.3 cm)
Depth	22" (55.9 cm)
Oven Interior	
Width	13" (17.1 cm)
Height	6 3/4" (3.3 cm)
Depth	12" (30.5 cm)
Weight	
Crated	73 lbs. (33 kg)
Uncrated	67 lbs. (30 kg)

Component Testing Procedures

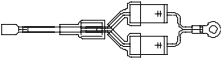
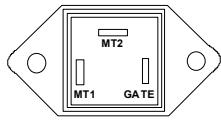
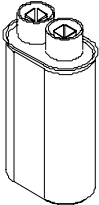

WARNING

To avoid risk of electrical shock, personal injury, or death, disconnect power to oven and discharge capacitor before servicing, unless testing requires it.

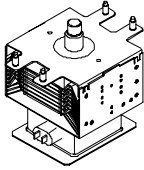
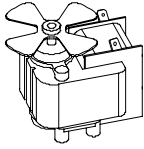
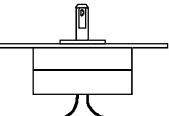
Illustration	Component	Testing	Results
	Thermal Cutout	Disconnect all wires from TCO. Measure resistance across terminals. Cavity Thermal Fuse Magnetron TCO.....	Open at 219° F (104° C). Open at 280° F (138° C) and closed at 180° F (82° C).
	Diode Assembly	Discharge Capacitors Remove diode lead from capacitor and connect ohmmeter. Reverse leads for second test.	Infinite resistance in one direction and 50KΩ or more in the opposite direction. NOTE: Analog meter must contain a battery of 6 volts minimum.
	Triac	Disconnect wires to triac. Measure resistance from: MT1 to MT2 MT1 to Gate MT2 to Gate All terminals to ground.....	Caution - Do not operate oven with wire to terminal MT2 removed. Infinite. Approximately 40 Ω or more. Infinite. Infinite.
	Capacitor Doubler	Discharge Capacitors Remove wires from capacitor terminals and connect ohmmeter, set on highest resistance scale to terminals. Also check between each terminal and capacitor case.	Between Terminals: Meter should momentarily deflect towards zero then return to over 5 MΩ. If no deflection occurs, or if continuous deflection occurs, replace capacitor. Terminal to Case: Infinite resistance.
	Snubber Assembly	Disconnect wires to snubber. Measure resistance across terminals.....	Infinite.
	Magnetron	Discharge Capacitors Remove wires from magnetron and connect ohmmeter to terminals. Also check between each terminal and ground.	Between Terminals: Less than 1 Ω. Each terminal to ground measures Infinite resistance. NOTE: This test is not conclusive. If oven does not heat and all other components test good replace the magnetron and retest.
	Blower Motor	Remove all wires from motor. Measure resistance across coil.....	Approximately 30 Ω.
	Antenna motor	Remove all wires from motor. Measure resistance across terminals.....	Approximately 3.4 KΩ.
Wire Harness		Test continuity of wires	Continuity.

Component Testing Procedures

⚠ WARNING

To avoid risk of electrical shock, personal injury, or death, disconnect power to oven and discharge capacitor before servicing, unless testing requires it.

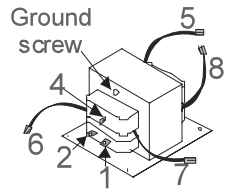
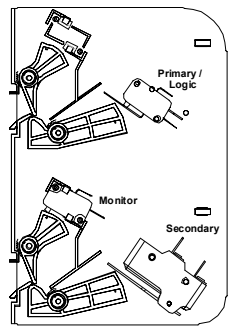
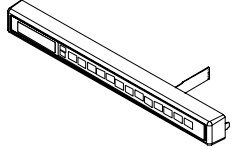
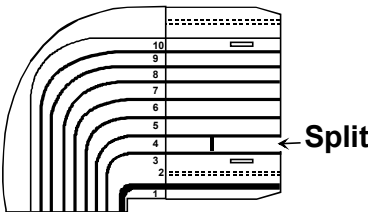
Illustration	Component	Testing	Results		
 <p>Terminal 1 - 120 V Terminal 2 - Common</p>	Transformer	<p>Discharge Capacitor Remove all wires from terminals, and measure resistance from:</p> <p>Terminal 1 to 2..... Terminal 5 to 6..... Terminal 7 to 8..... Terminal 4 to Ground screw on transformer... Terminal 4 to any other terminal</p>	<p>Less than 1 Ω. Less than 1 Ω. Less than 1 Ω. 40 Ω. Infinite resistance. If not, replace transformer.</p>		
	Interlock switch assembly	<p>Disconnect wires to switch.</p> <p>With door open measure resistance from:</p> <p>Terminal C to NC Monitor Terminal C to NO Primary..... Terminal C to NO Logic Terminal C to NO Secondary</p> <p>With door closed measure resistance from:</p> <p>Terminal C to NC Monitor Terminal C to NO Primary..... Terminal C to NO Logic Terminal C to NO Secondary</p> <p style="text-align: center;">Door Closed</p> <p>Primary / Logic C — ● — ● — NO</p> <p>Monitor C — ● — ● — NC</p> <p>Secondary C — ● — ● — NO</p>	<p>Continuity. Infinite. Infinite. Infinite.</p> <p>Infinite. Continuity. Continuity. Continuity.</p>		
	Touch Panel Assembly	<p>Continuity is indicated as 100 Ω and below.</p> <p>Pin 1: Ground.</p> 	<p>Pad</p> <p>1 2 3 4 5 6 7 8 9 0 Start Stop/Reset Power Level X 2 Time Entry</p>	<p>Trace</p> <p>8 & 10 7 & 10 6 & 10 5 & 10 4 & 10 3 & 10 8 & 9 7 & 9 6 & 9 5 & 9 4 & 9 4 & 8 5 & 8 6 & 8 7 & 8</p>	<p>Measurement</p> <p>Continuity Continuity Continuity Continuity Continuity Continuity Continuity Continuity Continuity Continuity Continuity Continuity Continuity Continuity Continuity Continuity Continuity</p>

Component Testing Procedures

⚠ WARNING

To avoid risk of electrical shock, personal injury, or death, disconnect power to oven and discharge capacitor before servicing, unless testing requires it.

Illustration	Component	Testing	Results
	<p>Controller board</p> <p>P1 connector used for touch panel ribbon</p>	<p>All Models</p> <p>Line voltage to control board P2 connector Pin 1—Pin 3.....</p> <p>Output drive voltage to triac Triac terminals..... Gate—T1.....</p> <p>120 VAC</p> <p>Fan relay (controls blower motor, antenna motor(s), and oven light) Control board..... Terminals C—J.....</p> <p>Cook relay Control board..... Terminals F—K.....</p>	<p>Line voltage (All Condition).</p> <p>0 VAC (Idle and Standby). 0.9 VAC (Cook).</p> <p>Line voltage (Idle). 0 VAC (Standby and Cook).</p> <p>Line voltage (Idle). 0 volts (Standby and Cook).</p>

Error Code Table

Error Code	Corrective Action
F1	Replace HV/LV Board
F2	Replace HV/LV Board
F3	Replace HV/LV Board
F4	Replace Touch Panel
F5	Replace HV/LV Board

Usage Test

The Usage Test is used to access Magnetron Hours, Magnetron Cycles and Door Cycles. Use the following procedure to access the data:

1. Open door.
2. Press and hold pad **3** for five (5) seconds.
NOTE: After five (5) seconds, SErv illuminates in the display.
3. Press pad **1** for Magnetron Hours.
4. Press pad **2** for Magnetron Cycles.
5. Press pad **3** for Door Cycles.

Conditions

Initial Power Up Condition: Apply power to oven with door closed—see, “Troubleshooting” section in the Service Manual (RS2240002).

Idle Condition: Oven plugged in, display blank (no other components operating).

Standby Condition: Open oven door, light and motors operate—see, “Troubleshooting” section in the Service Manual (RS2240002).

Cook Condition: Food load in oven, cook cycle initiated—see, “Troubleshooting” section in the Service Manual (RS2240002).

Component Testing Procedures



WARNING

To avoid risk of electrical shock, personal injury, or death, disconnect power to oven and discharge capacitor before servicing, unless testing requires it.

All Amana and Menumaster microwave oven power outputs are rated using the IEC705 standards. Using the IEC705 test method requires precision measurements and equipment that is not practical to be performed in the field. Using the test shown below will indicate if the oven performance is satisfactory.

Test equipment required:

- 1000 ml test container and thermometer (Amana power test kit R0157397 Fahrenheit / Menumaster power test kit M95D5 Celsius).
- Digital watch / watch with a second hand for use on ovens with electromechanical timers.

Important Notes:

- Low line voltage will cause low temperature rise / power output.
- Ovens must be on a dedicated circuit, properly grounded, and polarized. Other equipment on the same circuit may cause a low temperature rise / power output.
- This test and results are not a true IEC705 test procedure and are only intended to provide servicers with an easy means of determining if the microwave oven cooking output is correct.

Procedure

1. Fill the test container to the 1000 ml line with cool tap water.

NOTE: Water temperature should be approximately 60° F / 16° C.

2. Using the thermometer, stir water for five to ten seconds; measure, and record the temperature (T1).
3. Place test container of water in the center of oven cavity and close door.
4. Heat the water for a 33-second full power cycle.

NOTE: Use a digital watch or a watch with a second hand for ovens with electromechanical timers.

5. At end of the cycle, remove test container. Using the thermometer, stir water for five to ten seconds and record temperature (T2).
6. Subtract the starting water temperature (T1), from the ending water temperature (T2) to obtain the temperature rise (ΔT).
7. If the temperature rise (ΔT) meets or exceeds the minimum, the test is complete. If the temperature rise (ΔT) fails to meet the minimum temperature rise, test the line voltage to verify it is correct. Then repeat steps 1 - 6 making sure to change the water. If the temperature rise (ΔT) fails to meet the minimum temperature rise again the oven will require service.

Minimum Temperature Rise at Thirty -Three (33) Seconds Run Time

ΔT (°F)	Cooking Power Output	ΔT (°F)	Cooking Power Output	ΔT (°C)	Cooking Power Output	ΔT (°C)	Cooking Power Output
10	1000	20	2000	5	1000	11	2000
11	1100	21	2100	5.5	1100	11.5	2100
12	1200	22	2200	6.5	1200	12	2200
14	1400	24	2400	7.5	1400	13	2400
17	1700	25	2500	9.5	1700	13.5	2500
18	1800	27	2700	10	1800	15	2700
19	1900	30	3000	10.5	1900	16.5	3000

Wiring and Schematic Diagrams



WARNING

To avoid risk of electrical shock, personal injury, or death, disconnect power to oven and discharge capacitor before servicing, unless testing requires it.

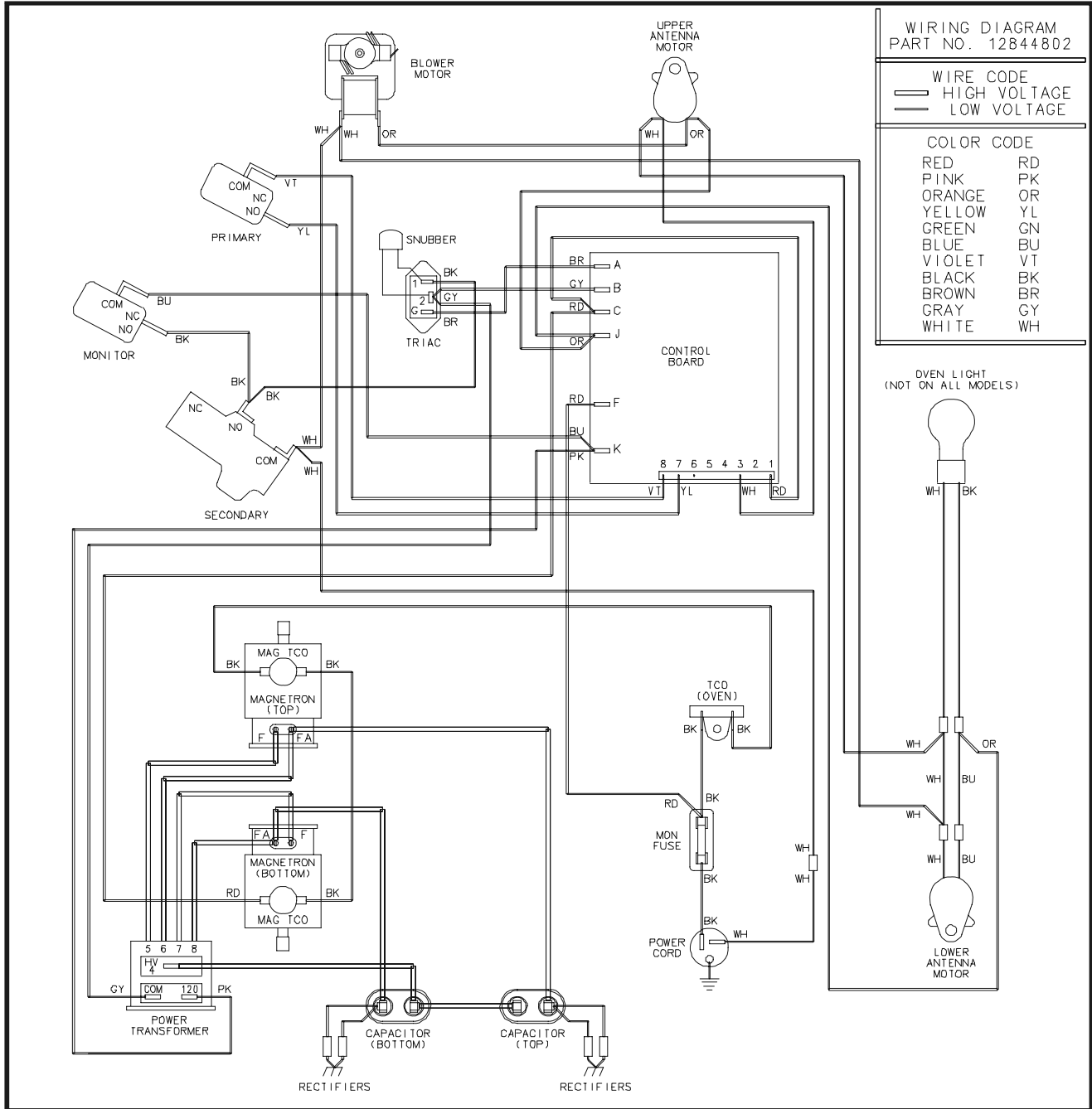

12844801



DANGER

HIGH VOLTAGE

Wiring and Schematic Diagrams



WARNING

To avoid risk of electrical shock, personal injury, or death, disconnect power to oven and discharge capacitor before servicing, unless testing requires it.

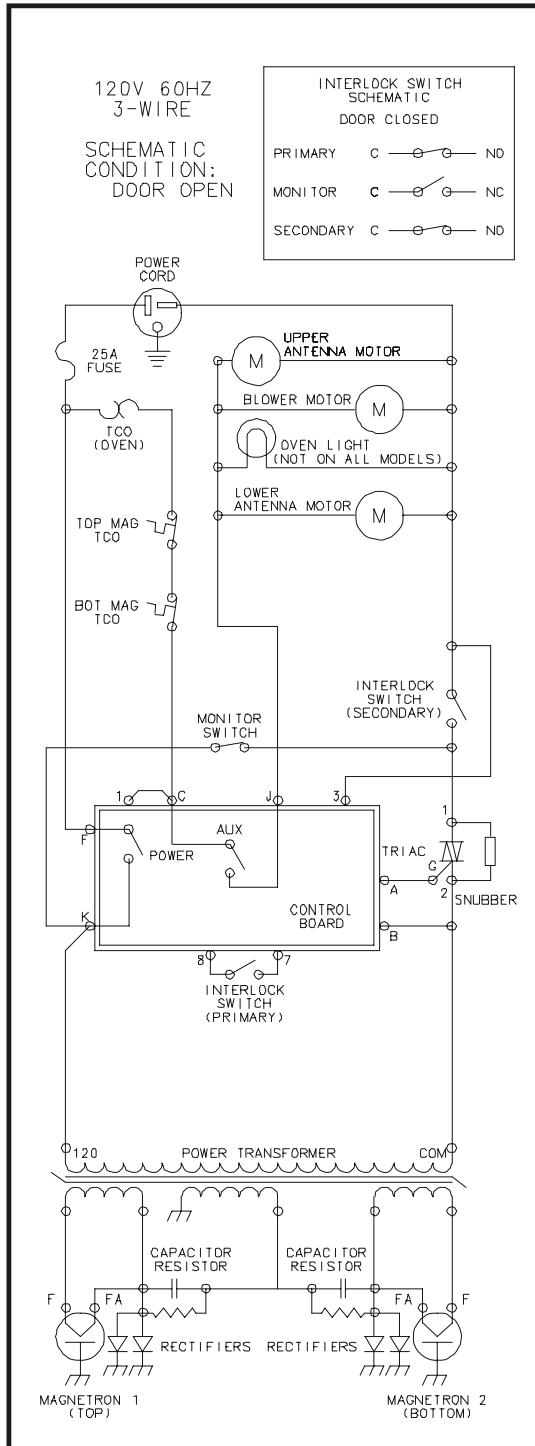

12844801



DANGER

HIGH VOLTAGE