

International Commercial Microwave—Technical Information

230 V, 50 Hz Models

UHDC5112	P1333110M	CHDC5142	P1333124M
HDC5142	P1333114M	UHDC5142	P1333114M
HDC5182	P1333117M	CHDC5182	P1333125M
UHDC5182	P1333118M	DEC11E2	P1333111M
UC11E2	P1333112M	DEC14E2	P1333115M
DEC18E2	P1333119M	UC14E2	P1333116M
UC18E2	P1333120M		

- Due to possibility of personal injury or property damage, always contact an authorized technician for servicing or repair of this unit.
- Refer to Service Manual RS5320013 for detailed installation, operating, testing, troubleshooting, and disassembly instructions.



CAUTION

All safety information must be followed as provided in Service Manual RS5320013.



WARNING



To avoid risk of electrical shock, personal injury, or death, disconnect power to oven and discharge capacitor before servicing, unless testing requires power.

Models	UHDC5112 UC11E2	DEC11E2	UHDC5142 UC14E2	HDC5142 CHDC5142 DEC14E2	UHDC5182 UC18E2	HDC5182 CHDC5182 DEC18E2
Power Source						
Voltage AC	230 VAC	230 VAC	230 VAC	230 VAC	230 VAC	230 VAC
Amperage (single unit)	13 A	13 A	13 A	13 A	13 A	13 A
Frequency	50 Hz	50 Hz	50 Hz	50 Hz	50 Hz	50 Hz
Single phase, 3 wire earthed	X	X	X	X	X	X
Plug	BS 1363A	CEE 7/7 Schuko	BS 1363A	CEE 7/7 Schuko	BS 1363A	CEE 7/7 Schuko
Power Output						
Nominal microwave energy (IEC705)	1100 Watts	1100 Watts	1400 Watts	1400 Watts	1800 Watts	1800 Watts
Minimum temperature rise (ΔT)	11°F/5.5°C	11°F/5.5°C	14°F/7.5°C	14°F/7.5°C	18°F/10°C	18°F/10°C
Operating frequency	2450 MHz	2450 MHz	2450 MHz	2450 MHz	2450 MHz	2450 MHz
Power Consumption						
Cook condition microwave	1800 Watts	1800 Watts	2300 Watts	2300 Watts	3000 Watts	3000 Watts
Dimensions						
Cabinet						
Width	423 mm	423 mm	423 mm	423 mm	423 mm	423 mm
Height	335 mm	335 mm	335 mm	335 mm	335 mm	335 mm
Depth	548 mm	548 mm	578 mm	578 mm	578 mm	578 mm
Oven Interior						
Width	331 mm	331 mm	331 mm	331 mm	331 mm	331 mm
Height	175 mm	175 mm	175 mm	175 mm	175 mm	175 mm
Depth	305 mm	305 mm	305 mm	305 mm	305 mm	305 mm
Weight						
Crated	29 kg	29 kg	31 kg	31 kg	31 kg	31 kg

Component Specifications

⚠ WARNING

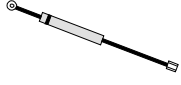
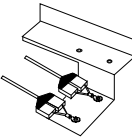
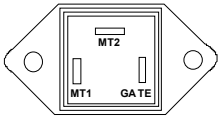
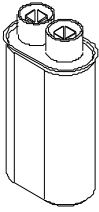
To avoid risk of electrical shock, personal injury, or death, disconnect power to oven and discharge capacitor before servicing, unless testing requires power.

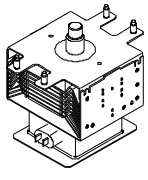
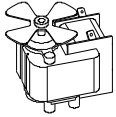
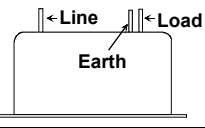
Illustration	Component	Testing	Results
	Thermal Cutout	Disconnect all wires from TCO. Measure resistance across terminals. Cavity Thermal Fuse Magnetron TCO.....	Open at 104° C (219° F). Open at 138° C (280° F) and closed at 82° C (180° F).
1100 Watt units  1400 and 1800 Watt units 	Diode Assembly	Discharge Capacitors Remove diode lead from capacitor and connect ohmmeter. Reverse leads for second test.	Infinite resistance should be measured in one direction and 50KΩ or more in the opposite direction. NOTE: Analog meter must contain a battery of 6 volts minimum.
	Triac	Disconnect wires to triac. Measure resistance from: MT1 to MT2 MT1 to Gate..... MT2 to Gate..... All terminals to ground.....	Caution - Do not operate oven when wire to terminal MT2 is removed. Infinite. Approximately 40 Ω or more. Infinite. Infinite.
	Capacitor	Discharge Capacitors Remove wires from capacitor terminals and connect ohmmeter, set on highest resistance scale to terminals. Also check between each terminal and capacitor case.	Between Terminals: Meter should momentarily deflect towards zero then return to over 5 MΩ. If no deflection occurs, or if continuous deflection occurs, replace capacitor. Terminal to Case: Infinite resistance.
	Snubber Assembly	Disconnect wires to snubber. Measure resistance across terminals.....	Infinite.
	Magnetron	Discharge Capacitors Remove wires from magnetron and connect ohmmeter to terminals. Also check between each terminal and ground.	Between Terminals: Less than 1 Ω. Each terminal to ground measures Infinite resistance. NOTE: This test is not conclusive. If oven does not heat and all other components test good, replace the magnetron and retest.
	Blower Motor	Remove all wires from motor. Measure resistance across coil	Approximately 30 Ω.
	Line filter	Line to Line Load to Load..... Line to Load Any terminal to Earth8 MΩ. .8 MΩ. Continuity. Infinite.
Wire Harness		Test continuity of wires	Continuity.

Component Specifications

⚠ WARNING



To avoid risk of electrical shock, personal injury, or death, disconnect power to oven and discharge capacitor before servicing, unless testing requires power.

Illustration	Component	Testing	Results																																																
	Transformer 1100 Watt 	Discharge Capacitor Remove all wires from terminals, and measure resistance from: 220 to Common 230 to Common Terminal 5 to 6 Terminal 4 to Earth screw on transformer Terminal 4 to any other terminal <div style="text-align: center;"> </div>	This transformer is equipped with a 155° C thermal cutout. 1.3 Ω. 1.3 Ω. <1 Ω. 70 Ω. Infinite resistance. If not, replace transformer.																																																
	Transformer 1800 and 1400 Watt 	Discharge Capacitor Remove all wires from terminals, and measure resistance from: 230 to Common Terminal 5 to 6 Terminal 7 to 8 Terminal 4 to Earth screw on transformer Terminal 4 to any other terminal	1 Ω. <1 Ω. <1 Ω. 45 Ω. Infinite resistance. If not, replace transformer.																																																
	Stirrer motor 230 VAC	Remove all wires from motor. Measure resistance across terminals	Approximately 12 KΩ.																																																
	Interlock switch assembly	Disconnect wires to switch. With door open measure resistance from: Terminal C to NO Primary Terminal C to NO Secondary Terminal C to NC Monitor With door closed measure resistance from: Terminal C to NO Primary Terminal C to NO Secondary Terminal C to NC Monitor <div style="text-align: center;"> Door Closed Primary / Logic C ● ● NO Monitor C ● ● NC Secondary C ● ● NO </div>	Infinite. Infinite. Continuity. Continuity. Continuity. Infinite.																																																
	Touch Panel Assembly	Continuity is indicated as 100 Ω and below. Pin 1: Ground. 	<table border="1"> <thead> <tr> <th>Pad</th> <th>Trace</th> <th>Measurement</th> </tr> </thead> <tbody> <tr><td>1</td><td>8 & 10</td><td>Continuity</td></tr> <tr><td>2</td><td>7 & 10</td><td>Continuity</td></tr> <tr><td>3</td><td>6 & 10</td><td>Continuity</td></tr> <tr><td>4</td><td>5 & 10</td><td>Continuity</td></tr> <tr><td>5</td><td>4 & 10</td><td>Continuity</td></tr> <tr><td>6</td><td>3 & 10</td><td>Continuity</td></tr> <tr><td>7</td><td>8 & 9</td><td>Continuity</td></tr> <tr><td>8</td><td>7 & 9</td><td>Continuity</td></tr> <tr><td>9</td><td>6 & 9</td><td>Continuity</td></tr> <tr><td>0</td><td>5 & 9</td><td>Continuity</td></tr> <tr><td>Start</td><td>4 & 9</td><td>Continuity</td></tr> <tr><td>Stop/Reset</td><td>4 & 8</td><td>Continuity</td></tr> <tr><td>Power Level</td><td>5 & 8</td><td>Continuity</td></tr> <tr><td>X 2</td><td>6 & 8</td><td>Continuity</td></tr> <tr><td>Time Entry</td><td>7 & 8</td><td>Continuity</td></tr> </tbody> </table>	Pad	Trace	Measurement	1	8 & 10	Continuity	2	7 & 10	Continuity	3	6 & 10	Continuity	4	5 & 10	Continuity	5	4 & 10	Continuity	6	3 & 10	Continuity	7	8 & 9	Continuity	8	7 & 9	Continuity	9	6 & 9	Continuity	0	5 & 9	Continuity	Start	4 & 9	Continuity	Stop/Reset	4 & 8	Continuity	Power Level	5 & 8	Continuity	X 2	6 & 8	Continuity	Time Entry	7 & 8	Continuity
Pad	Trace	Measurement																																																	
1	8 & 10	Continuity																																																	
2	7 & 10	Continuity																																																	
3	6 & 10	Continuity																																																	
4	5 & 10	Continuity																																																	
5	4 & 10	Continuity																																																	
6	3 & 10	Continuity																																																	
7	8 & 9	Continuity																																																	
8	7 & 9	Continuity																																																	
9	6 & 9	Continuity																																																	
0	5 & 9	Continuity																																																	
Start	4 & 9	Continuity																																																	
Stop/Reset	4 & 8	Continuity																																																	
Power Level	5 & 8	Continuity																																																	
X 2	6 & 8	Continuity																																																	
Time Entry	7 & 8	Continuity																																																	

Component Specifications

⚠ **WARNING**

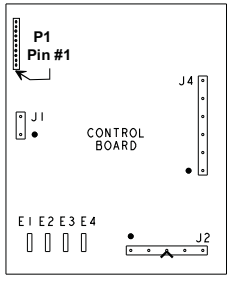
To avoid risk of electrical shock, personal injury, or death, disconnect power to oven and discharge capacitor before servicing, unless testing requires power.

Illustration	Component	Testing	Results
 <p>P1 connector used for touch panel ribbon</p>	Controller board 	Line voltage to control board E1—E3 Output drive voltage to triac Triac terminals Gate—T1 Fan relay (controls blower motor, antenna motor(s), and oven light) Control board Terminals J4-1—J2-2 Cook relay Control board Terminals E1—E4	Line voltage (All Conditions). 0 VAC (Idle and Standby). 0.9 VAC (Cook). Line voltage (Idle). 0 VAC (Standby and Cook). Line voltage (Idle). 0 volts (Standby and Cook).

Error Code Table

Error Code	Corrective Action
F1	Replace HV/LV Board
F2	Replace HV/LV Board
F3	Replace HV/LV Board
F4	Replace HV/LV Board
F5	Replace Touch Panel
F6	Replace HV/LV Board

Usage Test

The Usage Test is used to access Magnetron Hours, Magnetron Cycles and Door Cycles. Use the following procedure to access the data:

1. Open door.
2. Press and hold pad **3** for five (5) seconds.
NOTE: After five (5) seconds, SErv illuminates in the display.
3. Press pad **1** for Magnetron Hours.
4. Press pad **2** for Magnetron Cycles.
5. Press pad **3** for Door Cycles.

Conditions

- Initial Power Up Condition:** Apply power to oven with door closed.
- Idle Condition:** Oven plugged in, display blank (no other components operating).
- Standby Condition:** Open oven door, light and motors operate.
- Cook Condition:** Food load in oven, cook cycle initiated.

Component Specifications



WARNING

To avoid risk of electrical shock, personal injury, or death, disconnect power to oven and discharge capacitor before servicing, unless testing requires power.

Power Test

All Amana and Menumaster microwave oven power outputs are rated using the IEC705 standards. Using the IEC705 test method requires precision measurements and equipment that is not practical to be performed in the field. Using the test shown below will indicate if the oven performance is satisfactory.

Test equipment required:

- 1000 ml test container and thermometer (Amana power test kit Fahrenheit / Menumaster power test kit Celsius).
- Digital watch / watch with a second hand for use on ovens with electromechanical timers.

Important Notes:

- Low line voltage will cause low temperature rise / power output.
- Ovens must be on a dedicated circuit, properly grounded, and polarized. Other equipment on the same circuit may cause a low temperature rise / power output.
- This test and results are not a true IEC705 test procedure and are only intended to provide servicers with an easy means of determining if the microwave oven cooking output is correct.

Procedure

1. Fill the test container to the 1000 ml line with cool tap water.

NOTE: Water temperature should be approximately 60° F / 16° C.

2. Using the thermometer, stir water for five to ten seconds; measure, and record the temperature (T1).
3. Place test container of water in the center of oven cavity and close door.
4. Heat the water for a 33-second full power cycle.

NOTE: Use a digital watch or a watch with a second hand for ovens with electromechanical timers.

1. At end of the cycle, remove test container. Using the thermometer, stir water for five to ten seconds and record temperature (T2).
2. Subtract the starting water temperature (T1), from the ending water temperature (T2) to obtain the temperature rise (ΔT).
3. If the temperature rise (ΔT) meets or exceeds the minimum, the test is complete. If the temperature rise (ΔT) fails to meet the minimum temperature rise, test the line voltage to verify it is correct. Then repeat steps 1-6 making sure to change the water. If the temperature rise (ΔT) fails to meet the minimum temperature rise again the oven will require service.

Minimum Temperature Rise at Thirty-Three (33) Seconds Run Time

ΔT (°F)	Cooking Power Output	ΔT (°F)	Cooking Power Output	ΔT (°C)	Cooking Power Output	ΔT (°C)	Cooking Power Output
10.....	1000	20	2000	5	1000	11	2000
11.....	1100	21	2100	5.5.....	1100	11.5.....	2100
12.....	1200	22	2200	6.5.....	1200	12	2200
14.....	1400	24	2400	7.5.....	1400	13	2400
17.....	1700	25	2500	9.5.....	1700	13.5.....	2500
18.....	1800	27	2700	10.....	1800	15	2700
19.....	1900	30	3000	10.5.....	1900	16.5.....	3000

Wiring and Schematic Diagrams



WARNING

To avoid risk of electrical shock, personal injury, or death, disconnect power to oven and discharge capacitor before servicing, unless testing requires power.

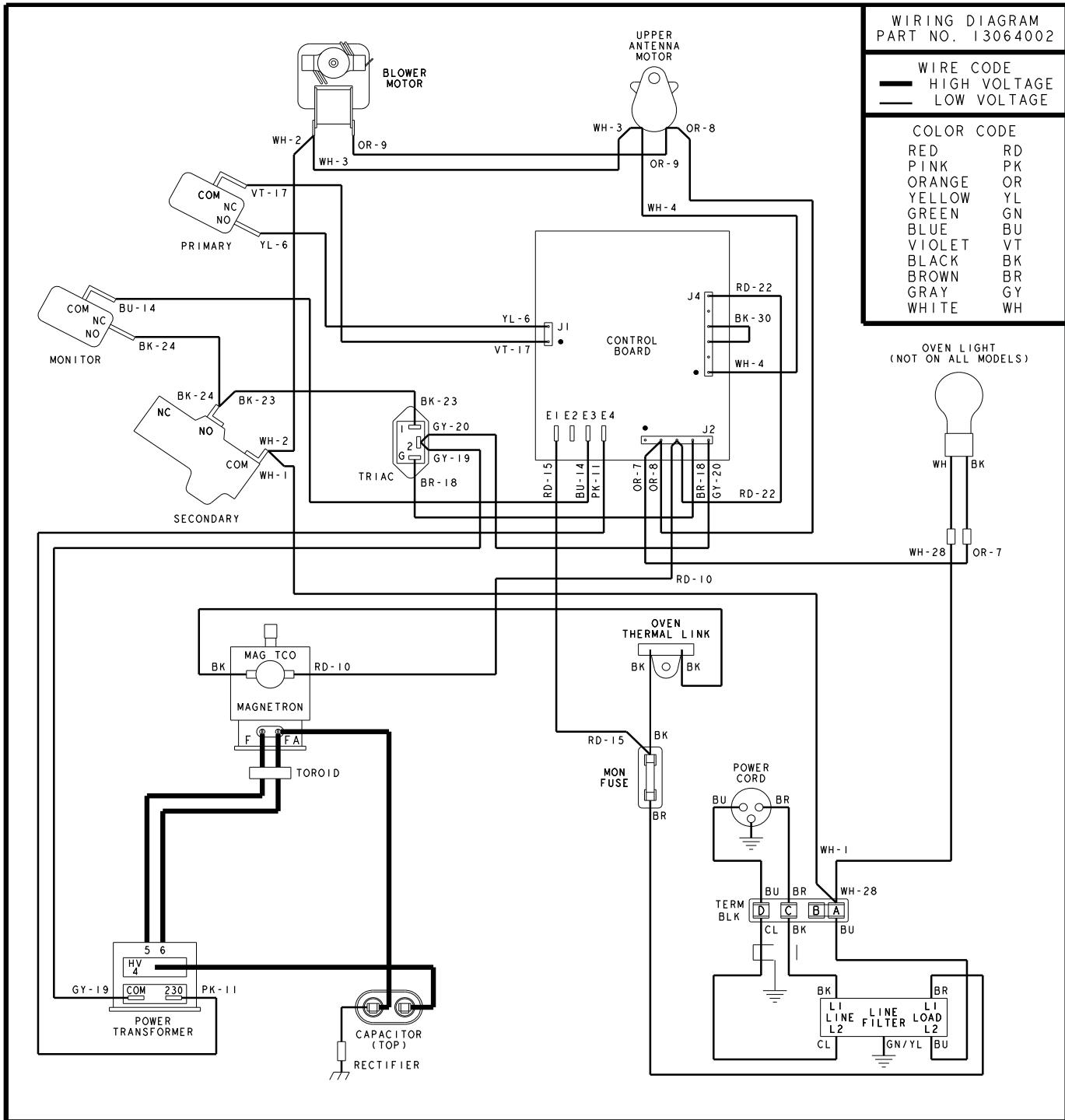

13064002

UHDC5112
DEC11E2

UC11E2

Wiring and Schematic Diagrams



WARNING

To avoid risk of electrical shock, personal injury, or death, disconnect power to oven and discharge capacitor before servicing, unless testing requires power.

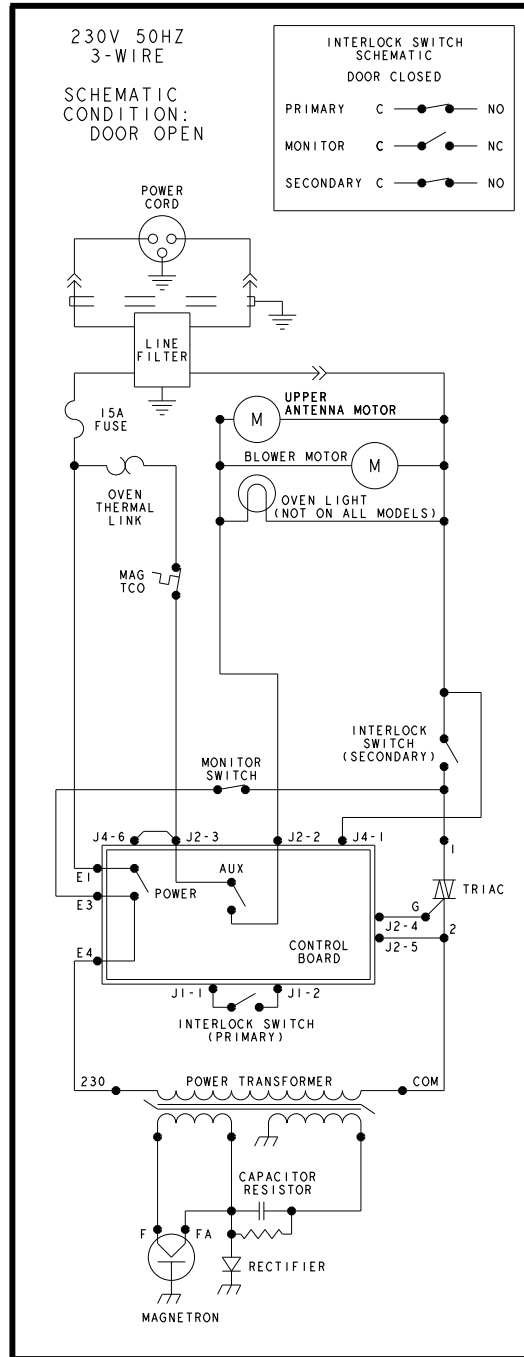

13064002



DANGER

HIGH VOLTAGE

UHDC5112
DEC11E2

UC11E2

Wiring and Schematic Diagrams



WARNING

To avoid risk of electrical shock, personal injury, or death, disconnect power to oven and discharge capacitor before servicing, unless testing requires power.

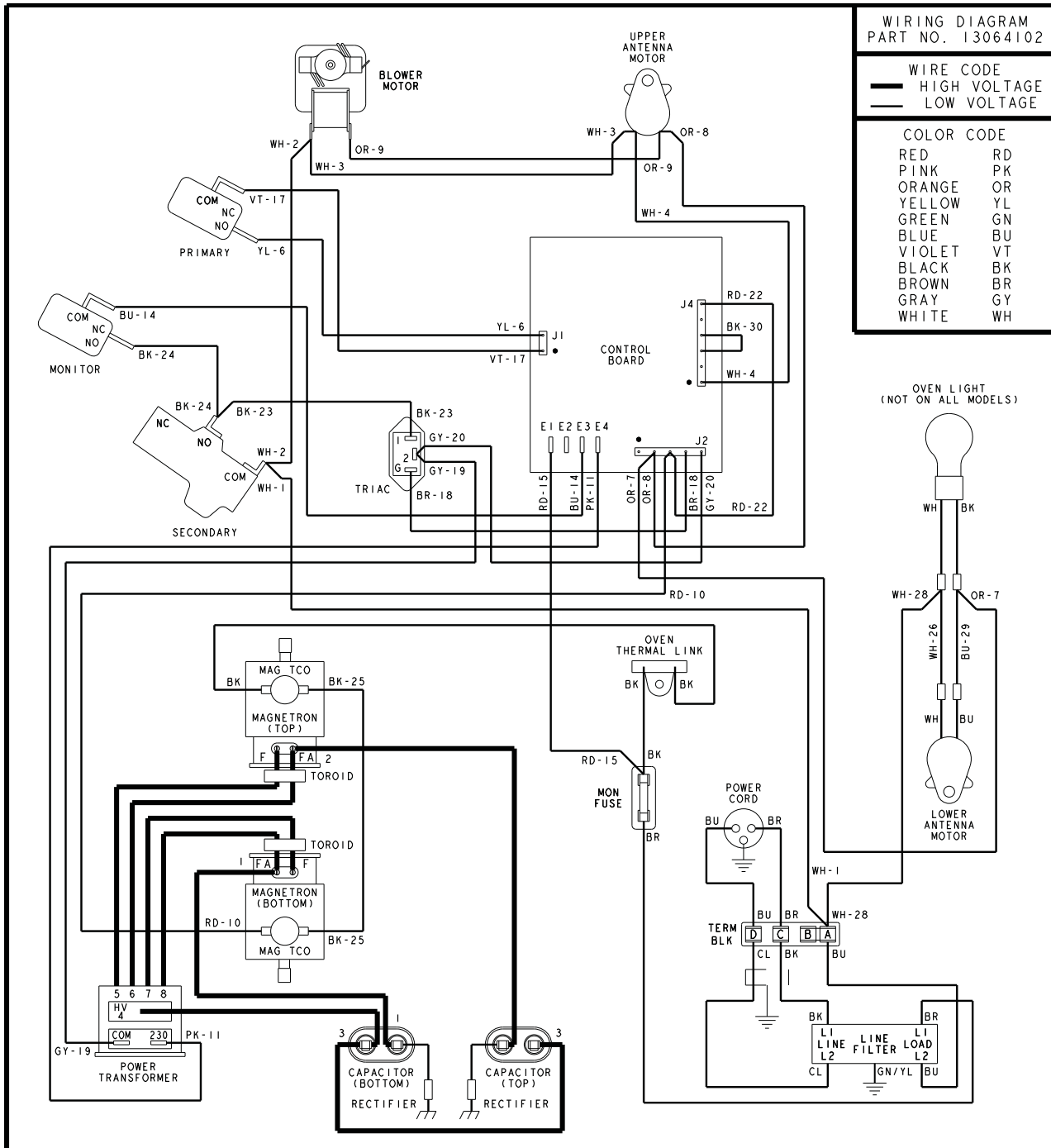

13064102

HDC5142
 DEC14E2
 HDC5182
 DEC18E2
 CHDC5142

UHDC5142
 UC14E2
 UHDC5182
 UC18E2
 CHDC5182

Wiring and Schematic Diagrams



WARNING

To avoid risk of electrical shock, personal injury, or death, disconnect power to oven and discharge capacitor before servicing, unless testing requires power.

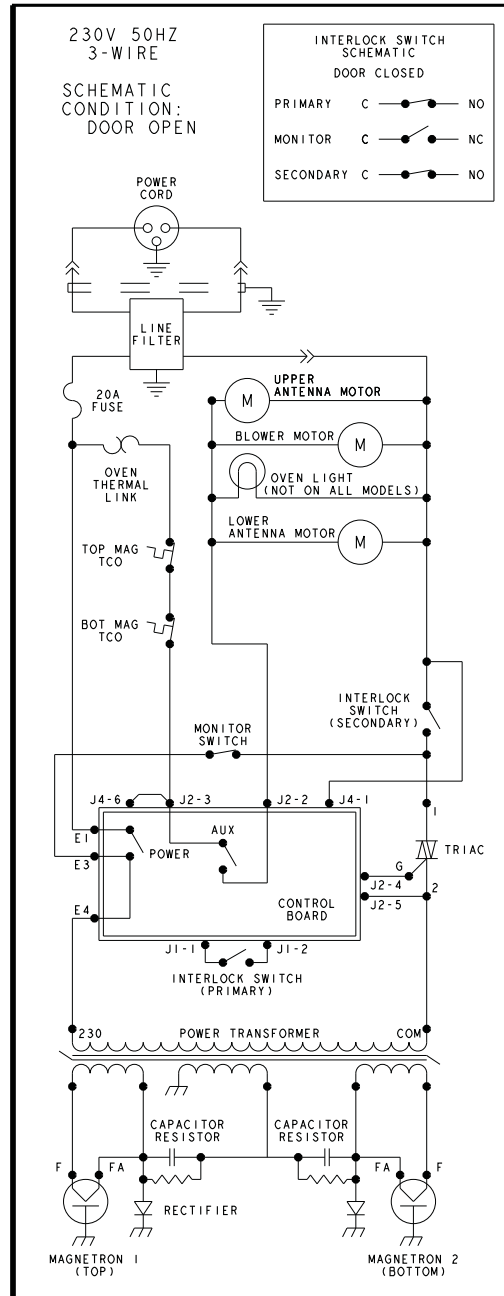

13064102



DANGER

HIGH VOLTAGE

HDC5142
DEC14E2
HDC5182
DEC18E2
CHDC5142

UHDC5142
UC14E2
UHDC5182
UC18E2
CHDC5182